

H-LINE Marine Diesel Engines

Operation manual



VH4.80

Operation manual



VH4.65

VH4.80

Serial numbers

Engine serial number VETUS:

Engine serial number Hyundai:

Gearbox serial number:

Please enter the serial numbers here.
These numbers should be quoted when inquiring about Customer Service, Repairs or Spare Parts (see page 6).

We reserve the right to make any changes without previous notice.

Copyright © 2024 VETUS B.V. Schiedam Holland

Please read and observe the information given in this operation manual. This will enable you to avoid accidents, preserve the manufacturer's warranty and maintain the engine in peak operating condition.

For the Guarantee Conditions, see the VETUS Diesel Service and Warranty Manual.

This engine has been built exclusively for the application specified in the scope of supply and is to be used only for the intended purpose. Any use exceeding that scope is considered to be contrary to the intended purpose. The manufacturer will not assume responsibility for any damage resulting therefrom. The risks involved are to be borne by the user.

Use in accordance with the intended purpose also implies compliance with the conditions laid down by the manufacturer for operation, maintenance and servicing. The engine should only be operated, maintained and serviced by persons which are familiar with the former and the hazards involved.

The relevant accident prevention guidelines and other generally accepted safety and industrial hygiene regulations must be observed.

Unauthorized engine modifications will invalidate any liability claims against the manufacturer for resultant damage.

Manipulations of the injection and regulating system may also influence the performance of the engine, and its emissions. Adherence to legislation on pollution cannot be guaranteed under such conditions.

VETUS is not liable for any damage caused by the addition of additives to the fuel, lubricating oil or cooling water system.

Contents

Serial numbers	1	5 Maintenance	6 Winter lay-up
1 Introduction	4	Checking the oil level	Winter storage procedure
2 Engine description		Checking the coolant level	Recommissioning after winter storage
General	6	Checking and cleaning the raw water strainer	55
Identification of engine parts	8	Draining water from the water separator/fuel filter (Bleeding)	7 Troubleshooting
Control panels	10	Battery, cables and cable connections	58
3 Use		Changing the oil	8 Technical Data
General guidelines	12	Checking the gearbox oil level	64
First commissioning	13	Changing the gearbox oil	9 Operating media
Running-in	16	Replacing the fuel filter	Lubrication Oil
Starting (Pre-heating)	17	Cleaning fuel lift pump	Fuel
Cruising	20	Checking the V-belts	Coolant
Stopping	22	Checking flexible engine mounts	68
4 Routine maintenance		Checking hose connections	10 Wiring Diagrams
Introduction	23	Checking fastenings	69
Maintenance schedule	24	Checking valve clearance	11 Overall Dimensions
		Checking the raw water pump	72
		Coolant replacement	
		Cleaning the heat exchanger	
		Checking engine rpm	

Introduction

Dear Customer,

VETUS diesel engines are designed both for pleasure and commercial craft. Consequently, a wide range of variants are offered to meet the requirements of specific cases.

Your engine is appropriately equipped for your vessel, which means that not necessarily all components described in this manual are mounted to your engine.

We have endeavoured to highlight any differences so that you will be able to locate the operating and maintenance instructions relevant to your engine quickly and easily.

Please read this manual before starting your engine and always observe the operating and maintenance instructions.

We are available to help with any additional inquiries.

VETUS B.V.

Safety measures

Warning indications

The following warning indications are used in this manual in the context of safety:



Indicates that great potential danger exists that can lead to serious injury or death.



Indicates that a potential danger that can lead to injury exists.



Indicates that the usage procedures, actions etc. concerned can result in serious damage to or destruction of the engine. Some CAUTION indications also advise that a potential danger exists that can lead to serious injury or death.



Emphasises important procedures, circumstances etc.

Symbols



Indicates that the relevant procedure must be carried out.



Indicates that a particular action is forbidden.

Pass the safety precautions on to other people who will use the engine.

General rules and laws concerning safety and accident prevention must always be observed.



This product should only be operated by persons who have read and understood the instructions and precautions in this manual. Failure to follow the instructions in this manual may result in serious injury or property damage. The manufacturer shall not be liable for any damages resulting from improper operation.

Introduction

- Never attempt to touch moving parts when the engine is running.
- Never touch hot parts of the engine, and keep flammable materials well away from the engine.
- Always stop the engine before checking or adjusting components.
- Always stop the engine before checking or topping up the coolant or oil.
- **NEVER** open cap on top of header tank when the engine is at operating temperature.
- Always carry out maintenance safely by only using tools well matched in size.

Engine description

General

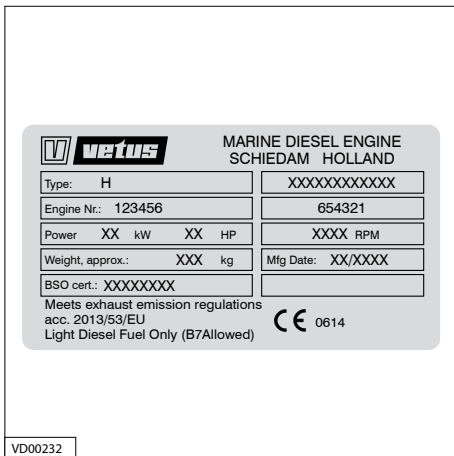

Engine data tag

The **VETUS** engine serial number and performance data are printed on the engine data tag.

Model and engine serial number must be given when ordering spare parts.



Engine data tag location

The **VETUS** engine data tag is attached to the valve cover.

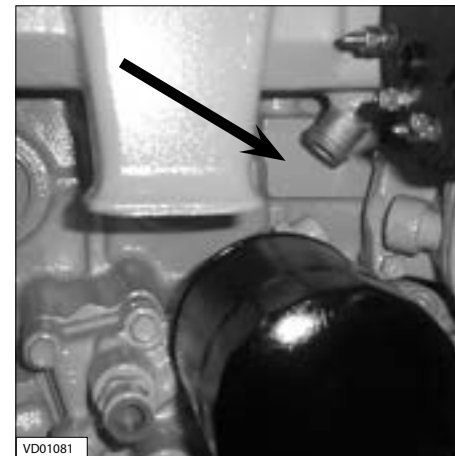

Engine serial number

The **HYUNDAI** engine serial number is stamped at the indicated spot.

General

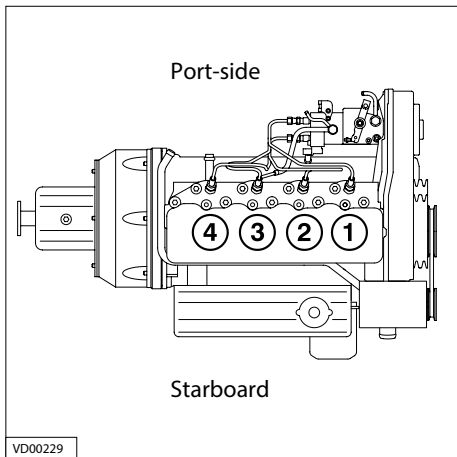

Cylinder numbering

Cylinders are numbered consecutively, beginning at the front end.

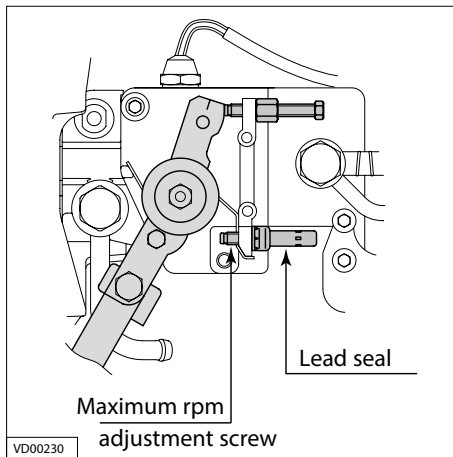

Fuel pump seal

The manufacturer shall not be held liable for damages resulting from adjustments made to the fuel injection pump. The maximum engine speed adjustment screw has been sealed to prevent this.

Engine description



CAUTION

Adjustments to the fuel pump are to be carried out by authorized VETUS-Service specialists only.

Engine description

Identification of engine parts Starboard

- 1 Airvent connection
- 2 Exhaust injection bend
VH4.65: \varnothing 60 mm
VH4.80: \varnothing 75 mm
- 3 Lifting eye
- 4,5 Cooling system drain plug
- 6 Heat exchanger
- 7 Expansion tank
- 8 Filler cap for cooling system
- 9 Alternator
- 10 V-belt alternator/ coolant pump
- 11 V-belt raw water pump
- 12 Raw water inlet \varnothing 25 mm
- 13 Raw water pump
- 14 Oil filter
- 15 Oil cooler
- 16 Raw water drain plug
- 17 Calorifier connection, engine 'IN'
(\varnothing 22 mm)
- 18 Connection for throttle push-pull
cable
- 19 Cooling system air bleed nipple
- 20 Temp. switch coolant

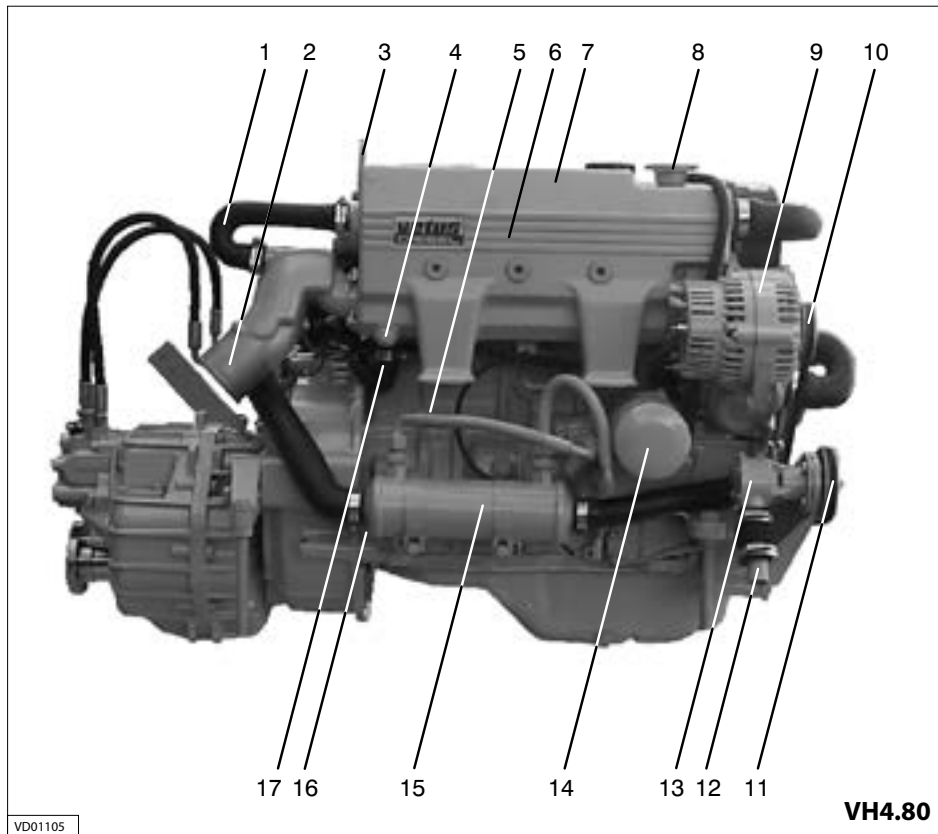

Identification of engine parts

Port-side

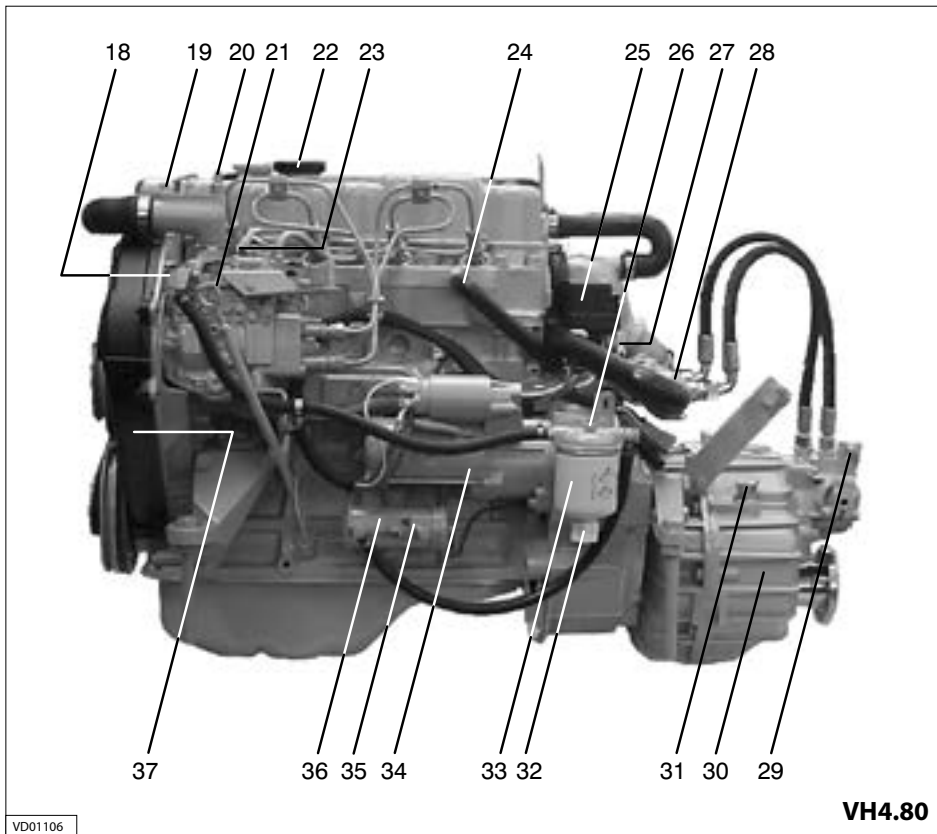

Engine description

- 21 Oil dipstick
- 22 Oil filler cap
- 23 Fuel return pipe connection \varnothing 8 mm
- 24 Calorifier connection, engine 'OUT' (\varnothing 17 mm)
- 25 Electrical system connection box
- 26 Water separator/fuel filter air bleed nipple
- 27 Fuse
- 28 Gearbox lube oil cooler
- 29 Connection for gearbox push-pull cable
- 30 Gearbox
- 31 Gearbox filler cap/ oil dipstick
- 32 Water separator/ fuel filter drain plug
- 33 Water separator/ fuel filter
- 34 Starter motor
- 35 Fuel supply pipe connection \varnothing 8 mm
- 36 Fuel lift pump
- 37 Distribution cover

VD01106

Engine description

Control panels

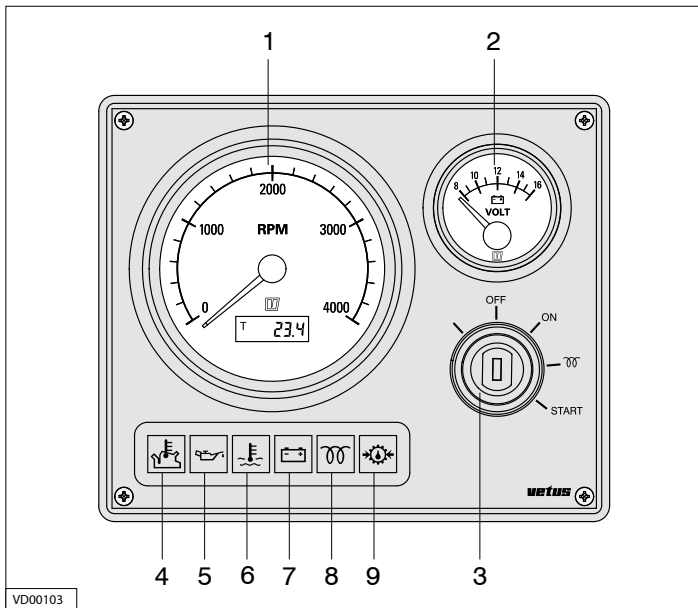

Basic panel (model 22)

Fly-bridge panel (excl. voltmeter, model 21)

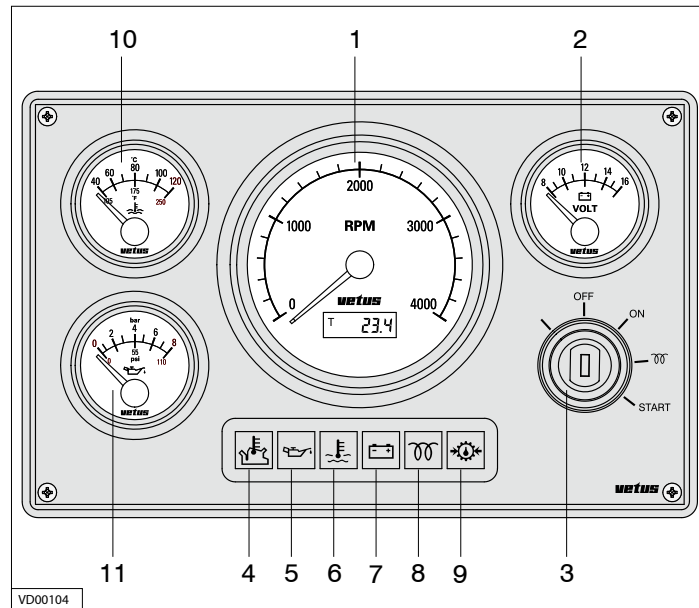

Extended panel (model 34)

Control panels

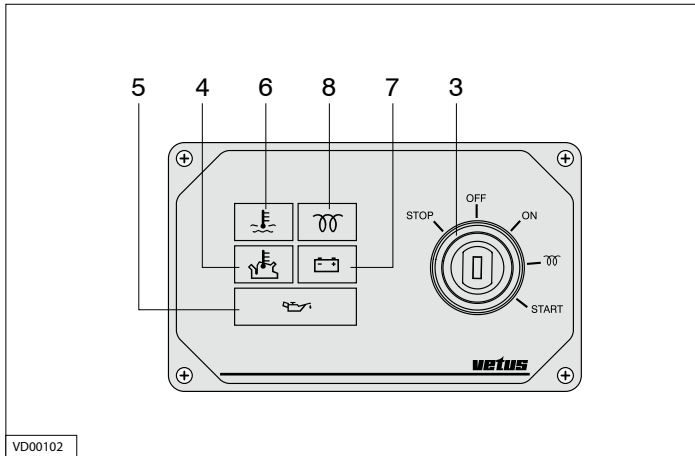

Sailingboat panel (model 10)

- 1 Tachometer/Operating hours counter
- 2 Voltmeter
- 3 Starter pre-heat switch/lock
- 4 Warning light high raw water temperature
- 5 Warning light low oil pressure
- 6 Warning light high coolant temperature
- 7 Warning light battery charging
- 8 Indicator light pre-heating
- 9 Warning light gearbox low oil pressure *

Engine description

- 10 Temperature gauge, coolant
- 11 Oil pressure gauge

*) This is an option, not fitted as standard.

General guidelines for use

Implementing the following recommendations will result in longer life and better performance and more economical operation of your engine.

- Carry out the maintenance described regularly, including the 'Daily procedures before starting'.
- Use anti-freeze in the engine coolant all year long, this helps prevent corrosion as

well as protecting against frost damage. For specifications see page 68.

- Never run the engine without a thermostat.
- Use a good quality lubricating oil. For specifications see page 66.
- Use a good quality diesel fuel that is free of water and other pollutants.

- Always stop the engine immediately if one of the warning lamps for oil pressure, high coolant temperature, high raw water temperature or battery charging lights up.



Commissioning the engine

Before starting the engine for the first time, the following procedures must be carried out:

Filling with engine oil

As a rule engines are delivered empty of oil. Fill the engine with oil through the filler neck on top of the valve cover, for quantity and specification see page 66.

Check the oil level with the dipstick, see page 25.

Engine Oil

4.9 litres (1.1 UKgal) 15W40

API: CD, CE or CF4

CCMC: D4, D5

For example:

- VETUS Marine Diesel Engine Oil
- Shell Rimula R4 15W40

Use

First commissioning

VETUS engines are normally equipped with ZF-Hurth or Technodrive gearboxes.

In case your engine is equipped with another brand of gearbox follow the instructions given in the supplied owners manual.



Filling gearbox with oil

- Fill the gearbox with oil.
- Check the oil level with the dipstick, see page 34.

ZF Hurth:

model ZF25A	: 1,8 litres	ATF*)
	(3.2 UKpt)	
model ZF25	: 2,5 litres	ATF*)
	(4.4 UKpt)	

Technodrive:

model TM345	: 1,6 litres	Engine oil
	(2.8 UKpt)	SAE 20W40-CD
model TM345A	: 1,6 litres	Engine oil
	(2.8 UKpt)	SAE 20W40-CD

*) ATF: Automatic Transmission Fluid type A, Suffix A.

*) ATF: Automatic Transmission Fluid type A, Suffix A.

First commissioning

Use

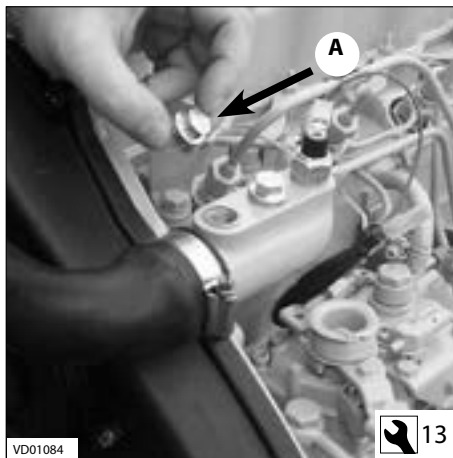
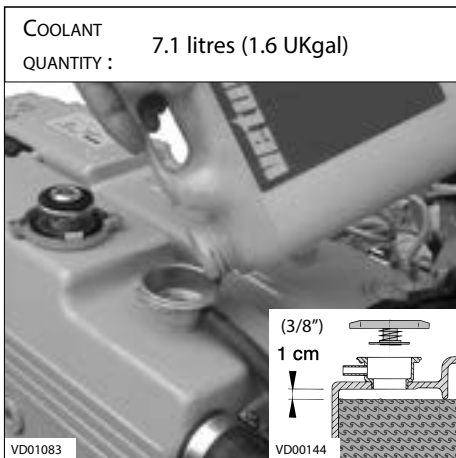

Filling the cooling system

Remove the cap of the filler neck on the top of the heat exchanger housing.

Remove plug A, so that air can escape from the cooling system.

Fill the cooling system. Replace plug A as soon as coolant flows out.

Use a mixture of 40% antifreeze (ethylene-glycol based) and 60% tap water or use a special coolant.

For specifications see page 68.

The level of the coolant must be approx. 1 cm (3/8") below the lower edge of the filler neck. Bleeding will take place automatically during filling!

Replace the filler cap.

After the engine has run for the first time and has reached operating temperature and has cooled down again to ambient temperature, check the coolant level in the heat exchanger housing.

WATER HEATER

If a water heater is connected to the engine and this heater is positioned above the upper side of the engine then bleeding of the heater will not take place automatically! Fill the heater separately to bleed the cooling system completely.

If necessary, add coolant.



CAUTION

Never fill the cooling system with sea water or brackish water.

Use

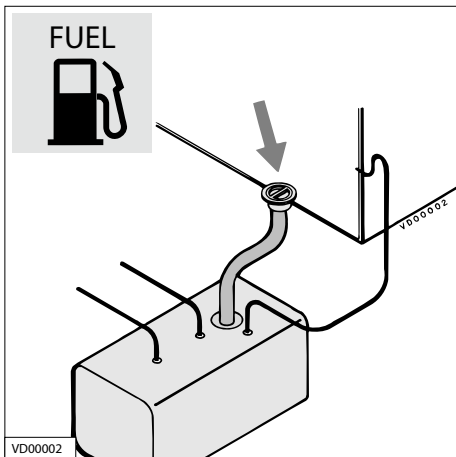

Fuel

- Ensure that the fuel tank is filled with diesel fuel.

Use only clean, water-free, commercial approved diesel fuel.

For fuel grade see page 67.

- Bleed the fuel system, see page 29.

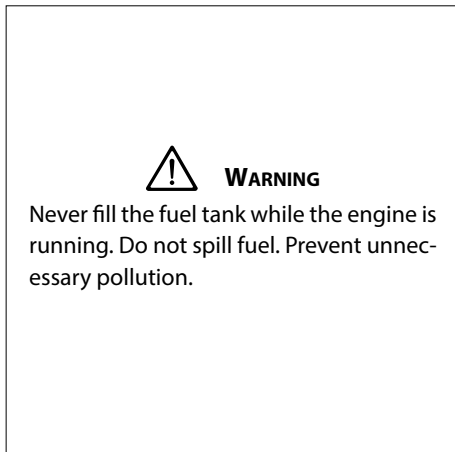

Other preparations

- Check battery and cable connections.
- Start the engine, see page 17, and let it run for about 10 minutes without load.
- Check the engine and all connections (fuel, cooling water and exhaust) for leaks.

First commissioning Running-in

Running-in

In order to ensure a long life for your engine, please observe the following for the first 50 operating hours:

- Allow the engine to reach operating temperature before applying a load.
- Avoid fast acceleration.
- Do not allow the engine to run faster than 3/4 of maximum RPM.

Starting

Before starting, **ALWAYS** check the following points:

- Engine oil level.
- Coolant level.
- Sea cock open.
- Main switch 'ON'.
- Gearbox in 'NEUTRAL' position.

After repair work:

- Check that all guards have been replaced and that all tools have been removed from the engine.

When starting with pre-heating, do not use any other substance (e.g. injection with 'Easy Start'). Doing so could result in an accident.

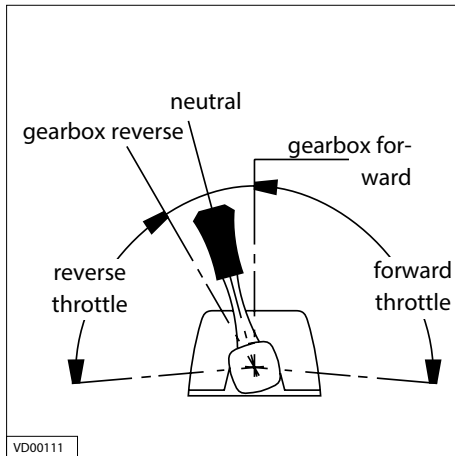

Preparation starting

Before starting the engine, always check that the control lever(s) is (are) in the neutral position.



WARNING

Never start the engine with the fuel injection pump removed. Disconnect battery.

Use



- Set the control lever to 'half throttle' **without** engaging the gearbox.

Use

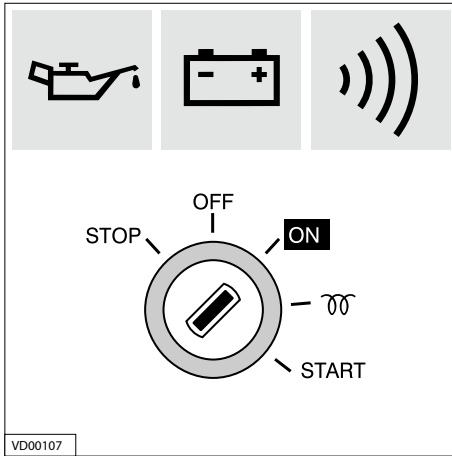

- Turn the start key on the instrument panel clock-wise; the warning lights for oil pressure and alternator will now light up and the alarm buzzer will sound.

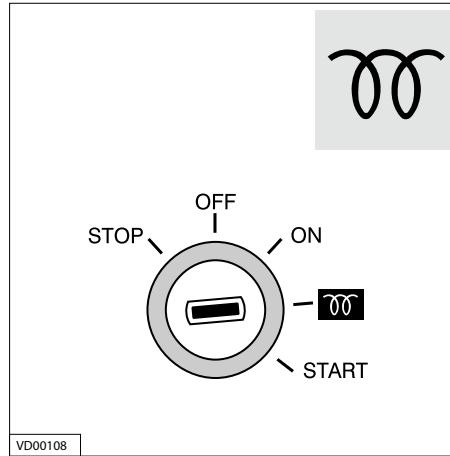

Pre-heating

- Turn the key further clockwise to the 'Pre-heating' position; only the pre-heating indicator light will be lit now.
- Hold the key in this position for about 2 seconds.

Starting

CAUTION

To prevent the glow plugs from burning out, **never** exceed the stated maximum pre-heating time.

Maximum pre-heating time is 3 seconds.

Starting

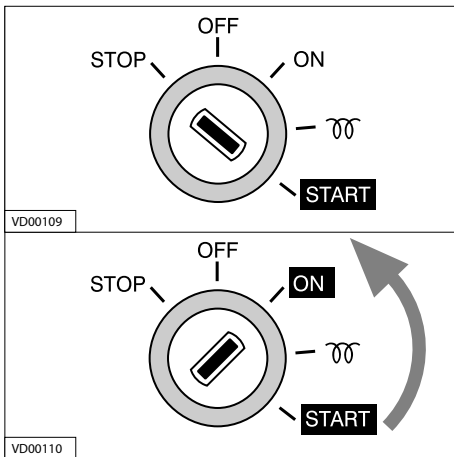

Starting

Now turn the key further to the 'START' position.

Release the key as soon as the engine fires (the key will return to the 'ON' position) and throttle back.

Leave the key in this position while the engine is running.



CAUTION

Release the key if the engine does not fire within 10 seconds.

Wait until the starter motor has stopped running completely before turning the key to the 'START' position again.

Never allow the starter motor to run for more than 30 seconds consecutively.

Check that the indicator lights for oil pressure and alternator are off.

Cooling water should now flow out of the exhaust; if this is not the case, stop the engine immediately.

Before submitting the engine to full load it should be brought up to operating temperature as quickly as possible by running at 3/4 of maximum revs. **NEVER** turn the main switch off while the engine is running.

Use

Use

The instrument panel is provided with the following instruments (Depending of the type of panel, see page 10 and 11).



WARNING

Never turn the key to the 'START' position while the engine is running.
Doing so will damage the starter motor.

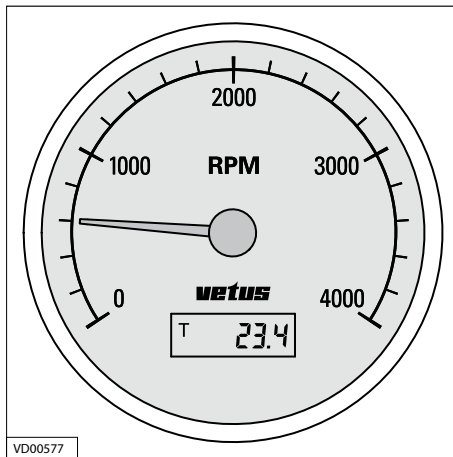

VD00577

Tachometer

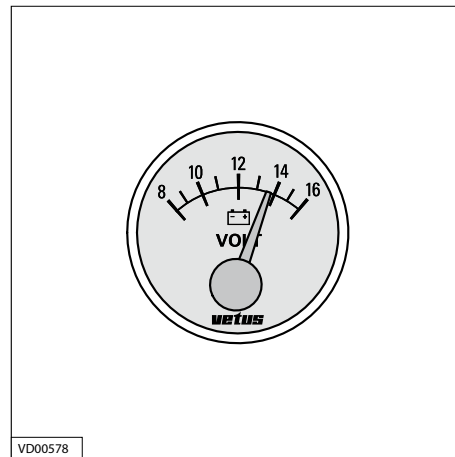

VD00578

Voltmeter

When the engine reaches operational temperature, exhaust gases should be colourless or light-blue. (In the winter, the low temperatures will turn the exhaust emissions white.) If black smoke is emitted from the exhaust, this indicates that combustion is incomplete. If white smoke is emitted, this indicates combustion of oil forced up.

Indicating the number of revolutions per minute of the engine.
Avoid idling for more than 10 minutes.
Also the number of running hours is indicated.

Idling speed,

VH4.65 : 850 rpm

VH4.80 : 850 rpm

Indicating the battery voltage.

When the engine is running, the battery voltage should be between 12 and 14 Volts.
With the engine stopped and the start key in the first position, the voltmeter should indicate 12 Volts.

Cruising

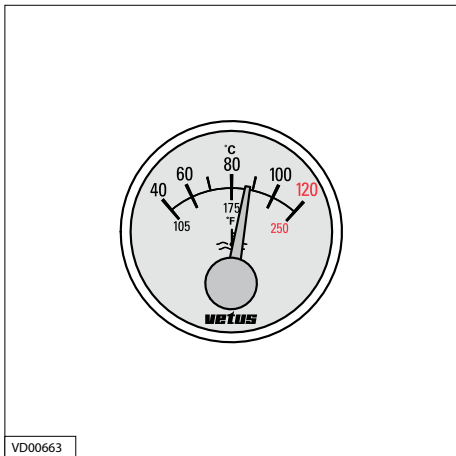

Temperature gauge

Indicating the temperature of the internal cooling system.

The operating temperature is 76°C - 85°C.

In case the engine is overheated: turn off the engine and establish the cause, see fault finding table, page 59 .. 63.

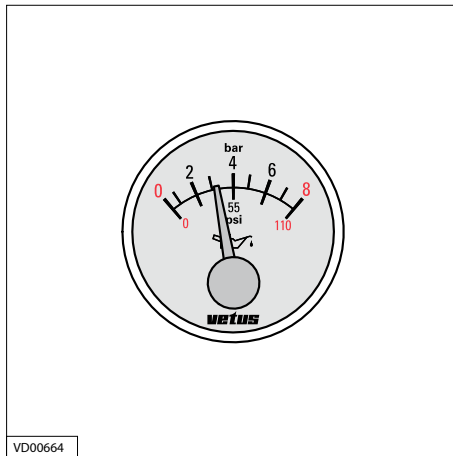

Oil pressure gauge

With the engine at operating temperature, the oil pressure is:

When idling: at least 0.8 bar (6 psi).

In case the oil pressure is too low: turn off the engine and establish the cause, see fault finding table, page 59 .. 63.

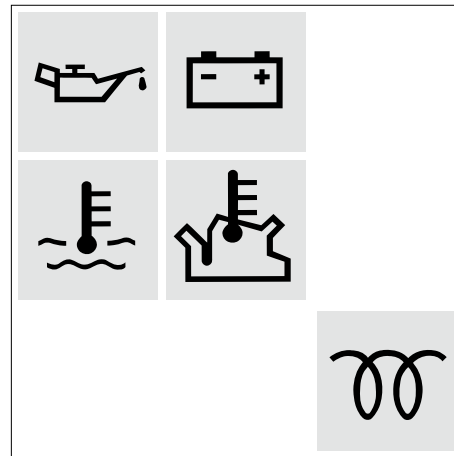

Warning lights

None of the five warning lights should light up while the engine is running. Oil pressure, battery charging and temperature indicator lights are all connected to an alarm buzzer. If this alarm buzzer sounds while running, **STOP THE ENGINE IMMEDIATELY!**

Use

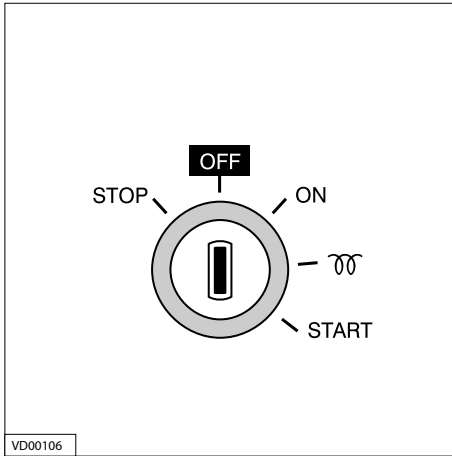

Stopping

Reduce engine speed to idle and shift the gearbox to '**NEUTRAL**'. Turn the key to the left to the '**OFF**' position.

If the engine is not to be used for some time, it is recommended that the sea cock is closed and the battery main switch turned off.

Stopping

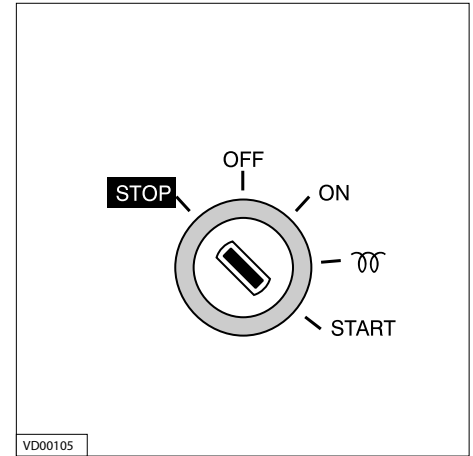

Never stop the engine immediately after it has been in operation for a long time. Allow the engine to idle for a few minutes before stopping.

N.B. The '**STOP**' position, left of the '**OFF**' position on the control panel, has normally no function for this engine.

When 2 control panels are connected to one engine, the engine can always be stopped by turning the key to the '**STOP**' position, no matter what the position is of the key on the other panel.

Introduction

Routine Maintenance

Introduction

The following guidelines should be observed for daily and periodic maintenance. Perform each function at the indicated time interval.

The intervals stated are for normal operational conditions. Service the unit more frequently under severe conditions.

Failure to carry out maintenance can result in faults and permanent damage to the engine.

No claim can be made on the Guarantee if maintenance has been neglected.

Routine Maintenance

Every 10 hours or daily, before starting	page
Check engine oil level	25
Check coolant level	26
Check water strainer	27
<hr/>	
After the first 50 hours	page
Drain water from fuel filter	28
Engine oil change	32
Replace oil filter	32
Gearbox oil change	35
Replace fuel filter	36
Check idle rpm	51
<hr/>	
Every 100 hours, at least once every year	page
Drain water from fuel filter	28
Battery, cables and cable connections	30
Check gearbox oil level	34
<hr/>	
Every 250 hours, at least once every year	page
Engine oil change	32
Replace oil filter	32

Maintenance schedule

Every 500 hours, at least once every year	page
Check engine oil level	35
Replace fuel filter	36
Cleaning fuel lift pump	37
Check V-belts	38
Check flexible engine mounts	40
Check engine for leaks	40
Check tightness of all fasteners, bolts and nuts	40
<hr/>	
Every 1000 hours, at least once every 2 years	page
Check valve clearance	41
Raw water pump inspection	44
Replace coolant	46
<hr/>	
Every 1600 hours	page
Replace timing-belt	*
<hr/>	
When required	page
Bleeding fuel system	29
Cleaning heat exchanger	48
Check idle rpm	51



DANGER

Stop the engine before carrying out any maintenance work

* Consult a VETUS Hyundai specialist!

Checking engine oil level

Daily, before starting.

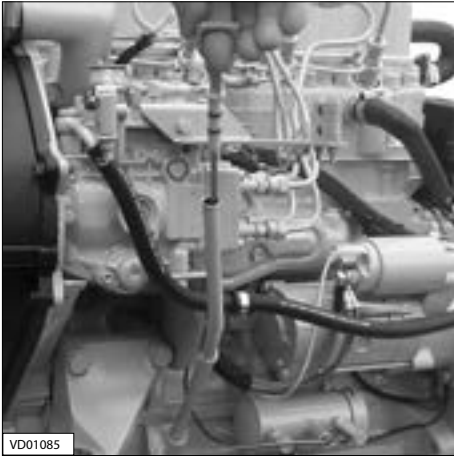

Check oil level

- Turn the engine off.

The dipstick is located on the port-side of the engine.

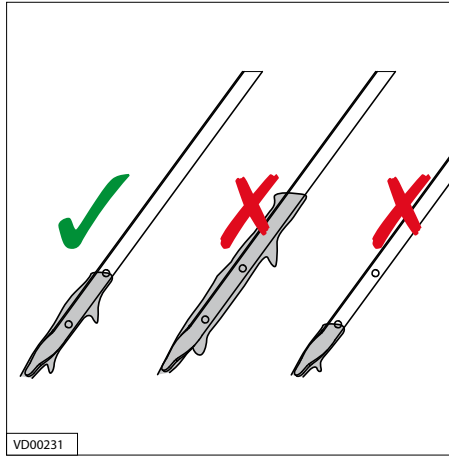

Oil level

The oil level must be at or near the upper mark on the dipstick*.

- If necessary top up with the same brand and type of oil.

*) The difference between the two oil level marks is: 1.2 litres (2 UKpt)

Maintenance



Topping up oil

The oil filling cap is on top of the the valve cover.

Maintenance



VD01086

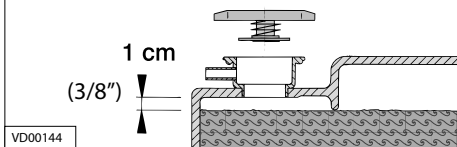

VD00144

Checking coolant level

- Check the coolant level in the header tank. This has to be checked when the engine is **cold**.
- Remove the cap of the filler neck on the heat exchanger.

The level of the coolant must be approx. 1 cm (3/8") below the lower edge of the filler neck.

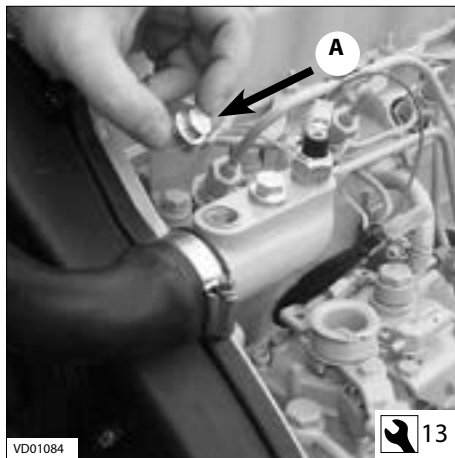

VD01084

13

- If necessary, top up.

When topping up coolant, remove plug A, so that air can escape from the cooling system.



WARNING

Never open the cap on the header tank when the engine is at operating temperature.

Checking coolant level

Daily, before starting.



VD01083

Topping up coolant

The internal cooling system can be filled with a mixture of anti-freeze (40 %) and tap water (60 %) or with a special coolant. For specification, see page 68.



CAUTION

Never fill the cooling system with sea water or brackish water.

Checking and cleaning the raw water strainer

Daily, before starting.

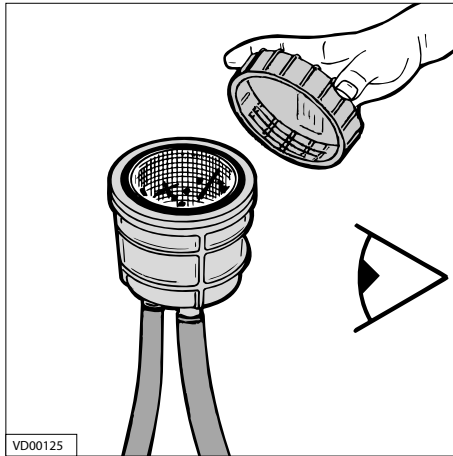

Checking the raw water strainer

- Check daily whether there is any dirt in the raw water strainer.

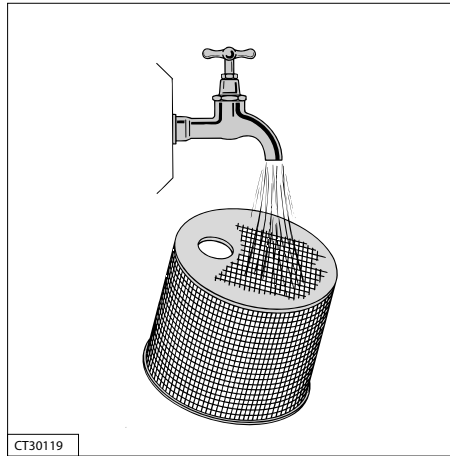

Cleaning the strainer

- Close the seacock before removing the lid of the water strainer.
- Clean the raw water strainer as often as is necessary, depending on the pollution of the waterways, but at least once every 6 months. A clogged raw water strainer will result in excessive temperatures or overheating of the engine coolant.
- Check the sealing between the lid and housing after cleaning and re-assembling the strainer. An improperly sealed lid will result in air sucked in by the sea water pump which again will result in overheating of the engine.

Maintenance

Draining of water from the water separator/fuel filter

Every 100 operating hours.



Empty fuel filter

- Open the drain plug at the lower side of the filter.
- Drain the water and close the drain plug.

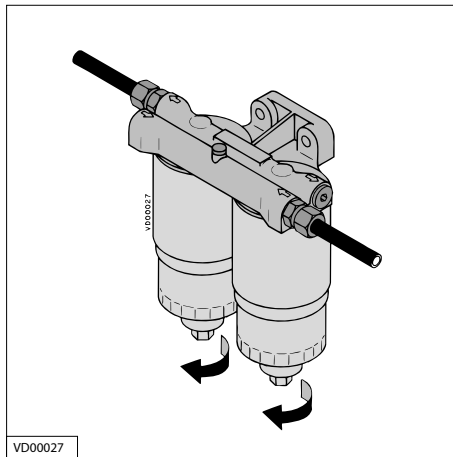

Empty water separator

Empty the separately installed water separator/fuel filter:

- Open the drain plug at the lower side of the filter.
- Drain the water and close the drain plug.

Note : The water separator is not within the scope of supply but installation is required!

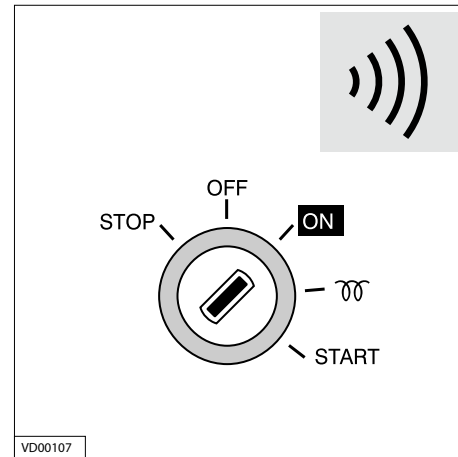

Bleeding

After the water separator/fuel filter has been drained, the air has to be bled from the fuel system.

The fuel system is self-bleeding.

Turn the key of the starter switch to position 'ON' and the fuel lift pump will feed the fuel system.

Draining of water from the water separator/fuel filter

Every 100 operating hours.



Open the bleeding nipple to speed up the bleeding process.

The bleeding nipple is located at the filter.

Close the bleeding nipple when all air has escaped.

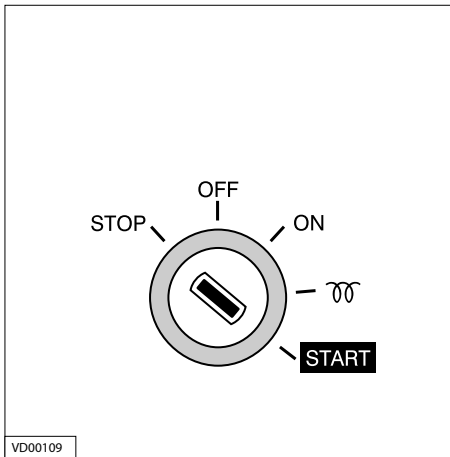

Start the engine

Operate the starter switch until the engine fires; release the starter switch if the engine does not fire within 20 seconds. Wait until the starter motor has stopped before making a new attempt to start the engine.

Repeat the above if the engine cuts out after a short time.

Maintenance

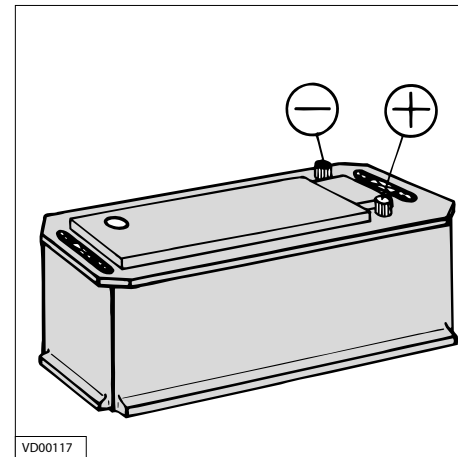

Battery, battery connections

Keep battery clean and dry.

Remove battery cables (negative first). Clean battery posts (+ and -) and clamps and grease with acid-free and acid-resistant grease.

Ensure that clamps make good contact after reassembling. Hand tighten the bolts only.

Maintenance

Battery, cables and connections

Every 100 operating hours.

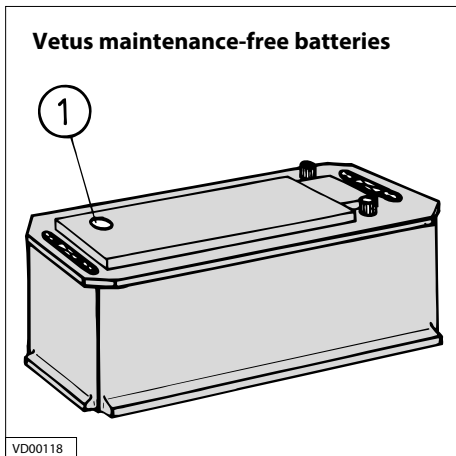

Checking specific gravity

Every VETUS Maintenance-free battery has a hydrometer (1) built into the cover.

Visual inspection of the hydrometer will show one of three conditions:

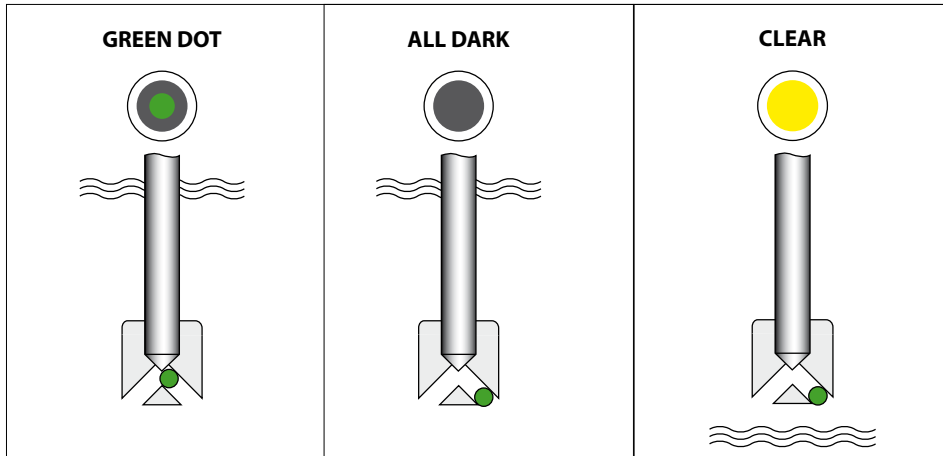

Hydrometer operation

Green dot visible:

State of charge 65 % or more.

Dark:

State of charge less than 65 %. Recharge immediately.

Clear or light yellow:

Electrolyte level low.

In case of low level, caused by overcharging the battery for a long period of time with a voltage too high, replace battery. Check alternator and/or voltage regulator.

Battery, cables and connections

Every 100 operating hours.

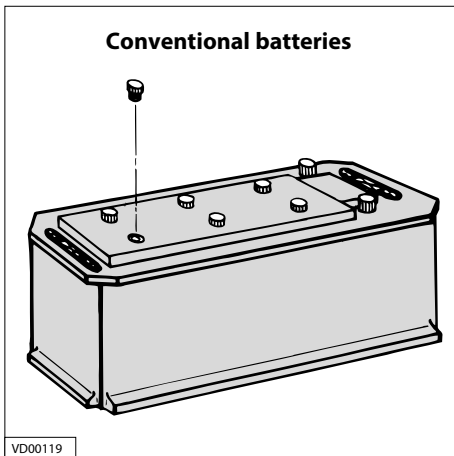

Checking electrolyte level

For conventional batteries it is required to check the electrolyte level regularly. Remove vent caps (taking care no spark or open flame is nearby) and inspect the level. Fluid should be 10 to 15 mm (3/8" to 5/8") above top of all plates. If necessary top up with distilled water. Replace vent caps and charge the battery for 15 minutes at 15 - 25 Amps to mix electrolyte.

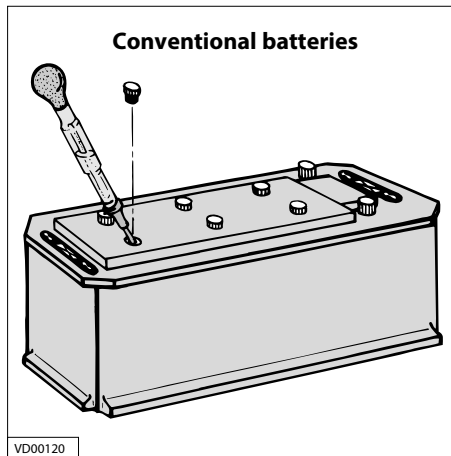

Checking specific gravity

Measure the electrolyte specific gravity of the individual cells with a commercial hydrometer. The hydrometer reading (see table) indicates the state of charge. Hydrometer reading of all cells should be at least 1.200 and show less than 0.050 between high and low. If not, recharge or replace battery. During checking the temperature of the electrolyte should preferably be 20°C (68°F).

Maintenance

Specific gravity	State of charge	
1.280	100%	
1.200	50%	recharge
1.120	10%	recharge immediately



DANGER

The gases emitted by the battery are explosive! Keep sparks and naked flames away from the battery!

Do not allow battery acid to come into contact with skin or clothing!

Wear protective goggles!

Do not rest tools on the battery!

Maintenance

Engine oil change

Change the engine oil every 250 hours of operation (together with engine oil filter replacement).

If the engine runs less than 250 hours during the year the oil should be changed at least once a year.

Run the engine for a few minutes before changing the oil; warm oil can be pumped out more easily.

Change the oil with a switched off engine at operation temperature. (Lube oil temperature approx. 80°C (176°F).)



DANGER

Be aware of the risk of skin burning during draining the hot oil! Used oil must be collected in a container for proper disposal according to laws and regulations.

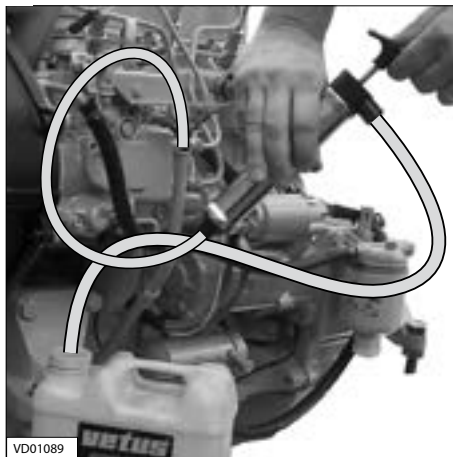

Draining the oil

Remove the dipstick; insert the suction hose of the supplied sump pump in the dipstick tube.

Push down the pump handle quickly and pull it up slowly.

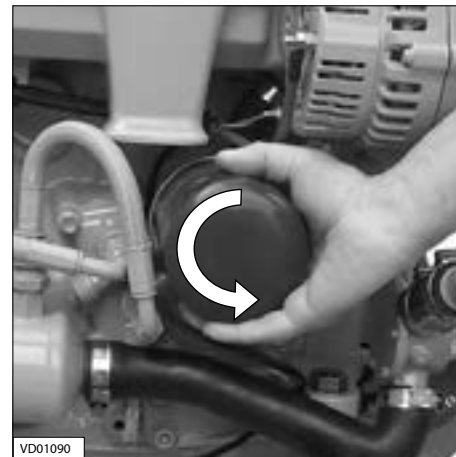

Removing the oil filter

Unscrew the oil filter, with a commercially available tool, when all the oil has been pumped out.

Catch any dripping oil.



DANGER

Beware of burns from hot oil.

Engine oil change

Every 250 operating hours.

OLIEFILTER, ART.CODE: STM4910

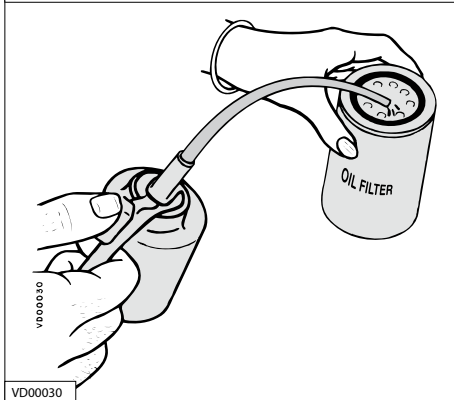

Oiling the oil seal

Clean the contact surface of the gasket. Lubricate the oil seal of the new filter element with clean engine oil.

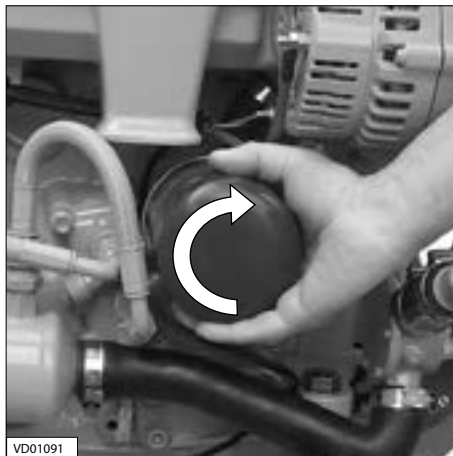

Oil filter installation

Install the filter in accordance with the instructions printed on the filter element housing.

AMOUNT OF OIL:
(OIL FILTER INCL.) 5.5 litres (1.2 UKgal)



Refilling with oil

Refill the engine with new oil (for specification see page 66) through the filler opening in the valve cover.

Operate the engine at idling speed for a short period of time. Check for oil leaks whilst the engine is running.

Stop the engine. Allow 5 minutes for the oil to return to the sump. Check the oil level with the dipstick.

Maintenance

Gearbox oil level check

Every 100 operating hours.

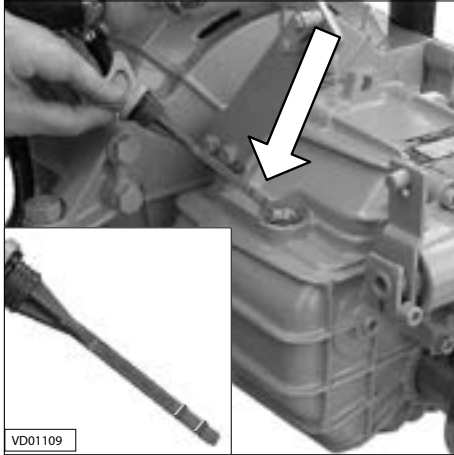

Oil level check (ZF-Hurth)

Unscrew the dipstick out of the gearbox housing.

The oil level must be between the two marks on the dipstick.

If necessary top up by pouring oil in the dipstick hole. For oil type and specification see page 66.

VETUS engines are normally equipped with ZF-Hurth or Technodrive gearboxes. Consult the supplied Owners Manual for more details about care and maintenance. In case your engine is equipped with another brand of gearbox follow the instructions given in the supplied owners manual for changing oil and other care and maintenance.

Changing the gearbox oil

Every 500 operating hours.



Draining the oil

Drain the oil with the aid of a separate sump pump.

Remove the dipstick (ZF-Hurth).

Insert the suction hose of the sump pump in the dipstick hole. Push down the pump handle quickly and pull it up slowly. Remove the sump pump when all the old oil has been pumped out.



Filling with new oil

Refill the gearbox to the correct level via the dipstick opening (ZF-Hurth).

For oil specification see page 66.

In case your engine is equipped with another brand of gearbox follow the instructions given in the supplied owners manual for changing oil and other care and maintenance.

Maintenance



Fuel filter removal

The fuel filter is to be replaced as a unit.

- Close the fuel stopcock.
- Remove the fuel filter, use a filter wrench. Catch any fuel.



DANGER

Keep naked flames away when working on the fuel system. Do not smoke!

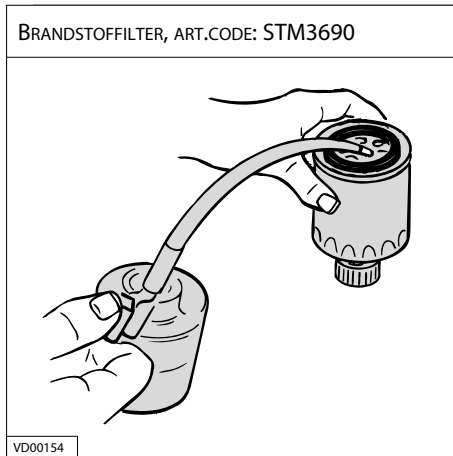

Fuel filter installation

- Clean any debris from the filter carrier rim.
- Lubricate the rubber gasket sparingly with clean engine oil.
- Fill the new filter with clean diesel fuel.

Fuel filter replacement

Every 500 operating hours.

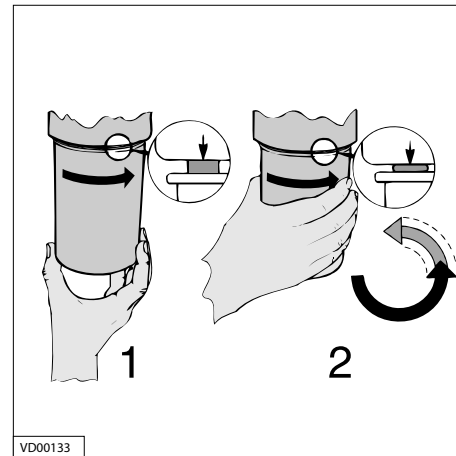

- Install the filter. When the rubber gasket touches the housing, apply another tightening of a half to three quarters of a turn by hand.

Cleaning fuel lift pump

Every 500 operating hours.

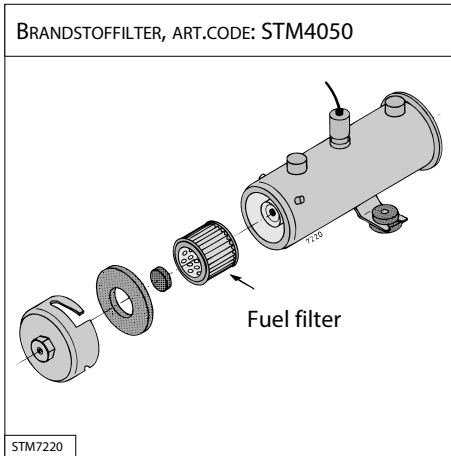

Fuel lift pump

- Check, and if necessary clean, filter inside the fuel lift pump.
- Open the fuel stop cock.
- Check for leakage.

Bleeding

After replacing the fuel filter and cleaning the pilot filter inside the fuel lift pump the air has to be bled from the fuel system.

For bleeding see page 29.

Maintenance

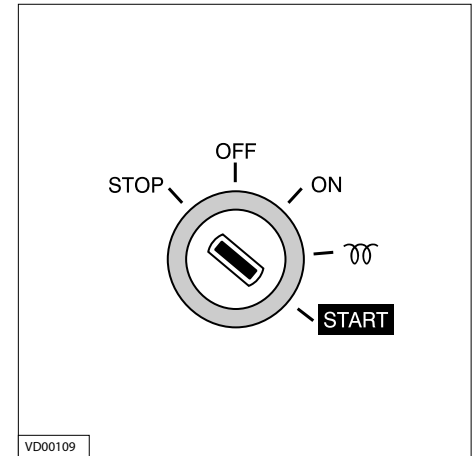

Start the engine

Operate the starter switch until the engine fires; release the starter switch if the engine does not fire within 20 seconds. Wait until the starter motor has stopped before making a new attempt to start the engine.

Repeat the above if the engine cuts out after a short time.

Maintenance

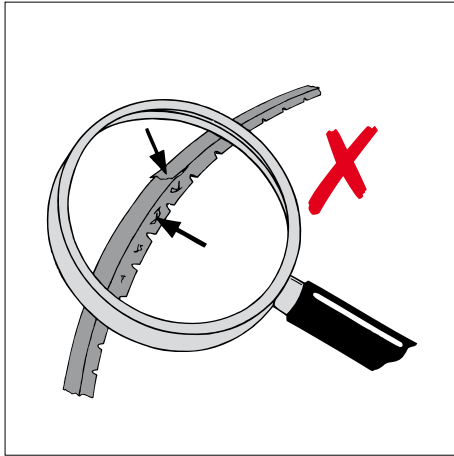

Inspection V-belts

Inspect the belts for wear and tear (fraying and cracking). Belts which are in poor condition should be replaced.

Check, tension and change belts only with the engine off. Refit belt guard, if provided.

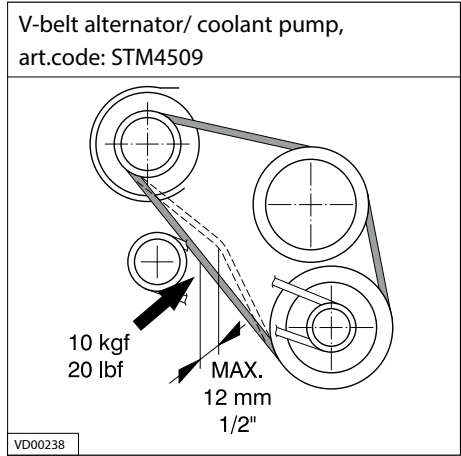

Checking tension V-belt alternator/ coolant pump

Check tension of the V-belt by applying moderate finger and thumb pressure. If the deflection of the belt is more than 12 mm (1/2"), using about 10 kg (20 lbs) thumb pressure, it should be tensioned.

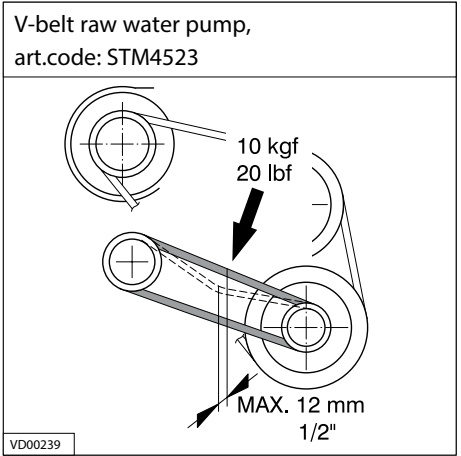

Checking tension V-belt raw water pump

Check tension of the V-belt by applying moderate finger and thumb pressure. If the deflection of the belt is more than 12 mm (1/2"), using about 10 kg (20 lbs) thumb pressure, it should be tensioned.

Checking the V-belts

Every 500 operating hours.

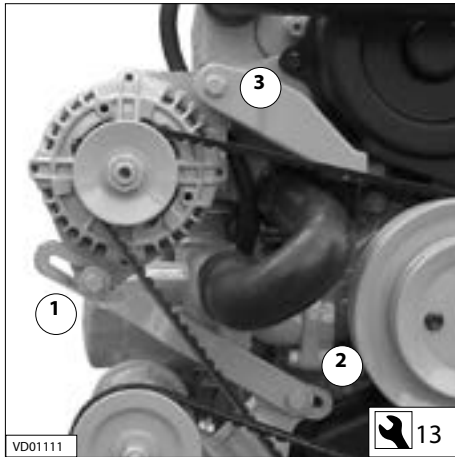

Tensioning V-belt alternator/coolant pump

Loosen the bolts of the adjustment bracket (1 and 2) and the alternator mounting bolt (3). Now push the alternator outwards until the belt tension is correct.

Now first re-tighten the mounting bolt (3) of the alternator.

Then re-tighten the bolts of the adjustment bracket (1 and 2).

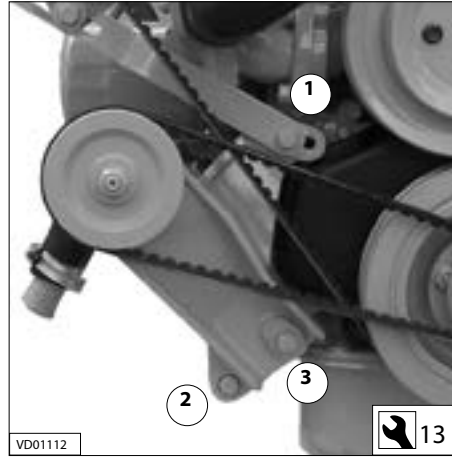

Tensioning V-belt raw water pump

Loosen the bolt of the adjustment bracket (1) and the mounting bolts (2 and 3).

Now push the raw water pump outwards until the belt tension is correct.

Re-tighten the bolts.

Maintenance

Flexible engine mounts, hose connections and fasteners

Every 500 operating hours.

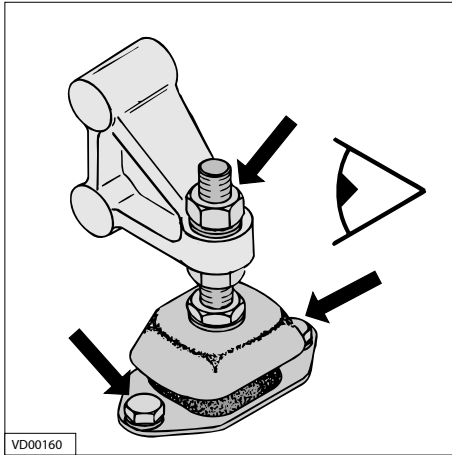

Check flexible engine mounts

Check the bolts which secure the damper element, the mounting bolts to engine bed and the nuts at the adjustment spindle for tightness.

Inspect the rubber element of the engine support for cracks. Also check the deflection of the damper element, the deflection influences the alignment of engine and propshaft! Re-align engine in case of doubt.

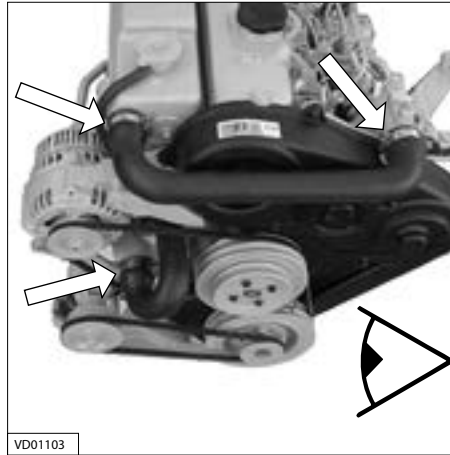

Inspection hose connections

Inspect all hose connections of the cooling system. (Cracked hoses, loose hose clamps)

Check fasteners

Check tightness of all fasteners, bolts and nuts.

Checking valve clearance

Every 1000 operating hours.

Maintenance

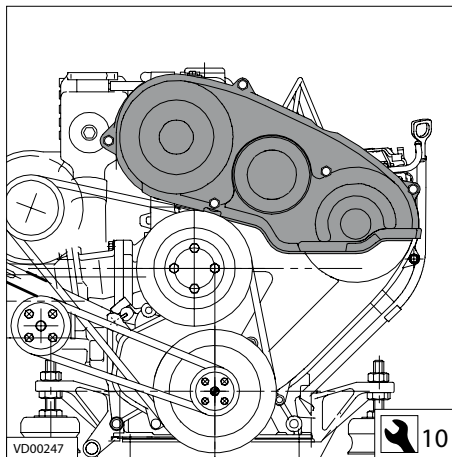

Checking / adjusting valve clearance

Checking the valve clearance must be done with a cold engine, that is an engine which did not run for at least 6 hours.

Remove distribution cover

Remove the 5 bolts of the distribution cover.



Remove rocker cover

Remove the 3 bolts of the rocker cover.
Complete the following steps:

Note: There are two TDC's e.g. compression and suction. At the TDC at the end of the compression stroke the rocker arm does

not move when the crank pulley is rotated a little.

Maintenance

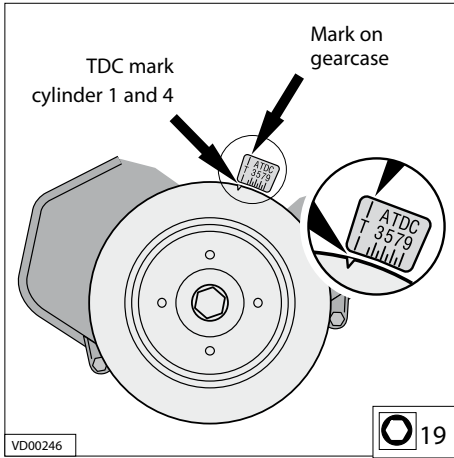

Locating TDC

Locate the Top Dead Center (TDC), at the end of the compression stroke, for cylinder 1 by barring the engine slowly until the TDC marks of the engine block and the crank pulley match.

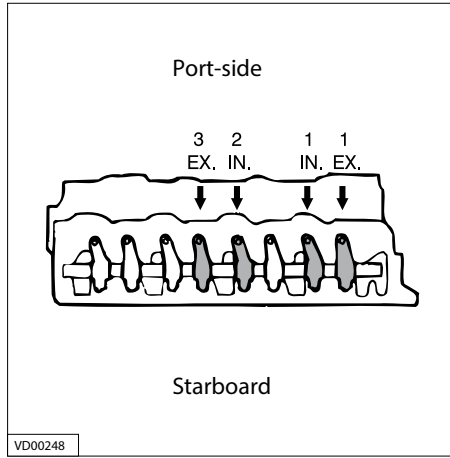

Adjusting valve clearance

- Check valve clearance at indicated valves and adjust if necessary.

Checking valve clearance

Every 1000 operating hours.

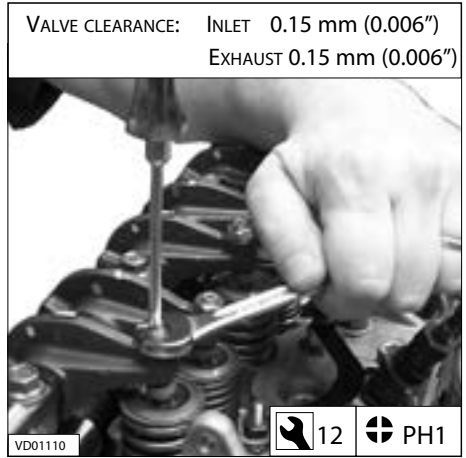

Checking valve clearance

Every 1000 operating hours.

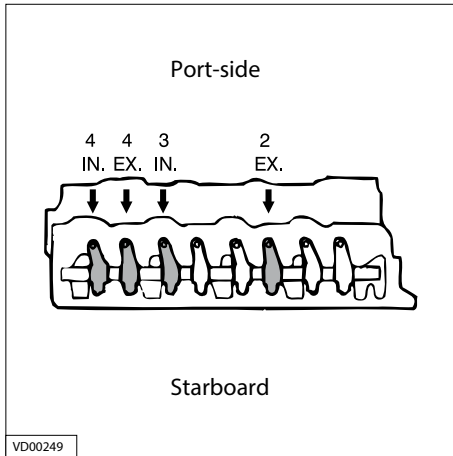

Adjusting valve clearance

- Rotate the crankshaft 360° clockwise.
- Check valve clearance at indicated valves and adjust if necessary.

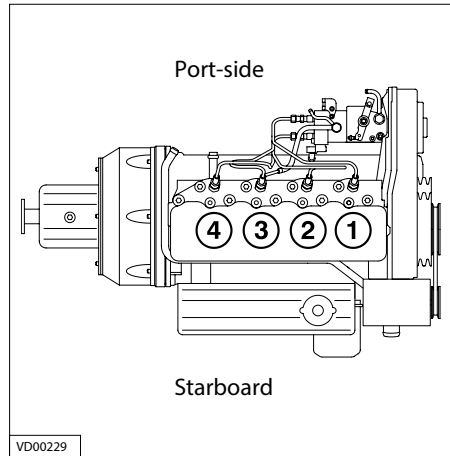

Cylinder numbering

Cylinders are numbered consecutively, beginning at the front end.

Maintenance

Raw water pump inspection

Every 1000 operating hours.

Raw water pump inspection

The rubber impeller of the outboard water pump is not proof against running dry. If the water supply has been blocked, it may be necessary to replace the impeller. Always carry a spare impeller on board.



Pump cover removal

Inspection where appropriate changing is as follows:

- Close the sea cock.
- Remove the cover of the pump by unscrewing the screws out of the housing.

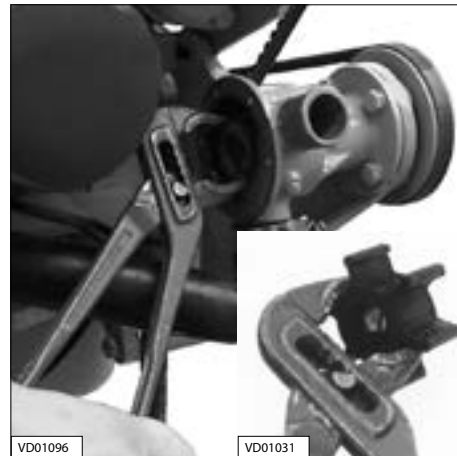

Impeller removal

- Slide the impeller off of the shaft using a waterpump plier.
- Mark the impeller to ensure correct re-installation if it is to be re-used. The impeller must be installed in the same position as removed.

Raw water pump inspection

Every 1000 operating hours.

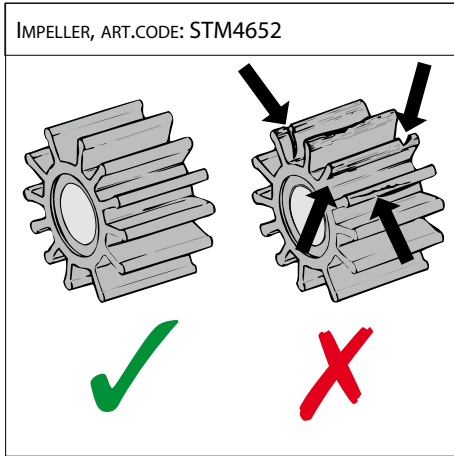

Impeller inspection

- Inspect the impeller for damage.
- Replace the impeller if necessary.

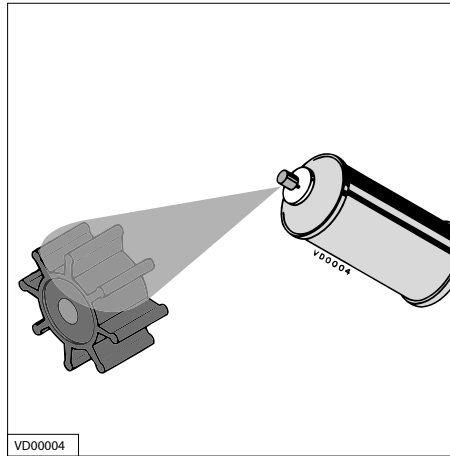

Re-install the impeller

- The impeller should be lubricated with glycerin or a non-petroleum based lubricant such as a silicone spray before fitting it into the impeller housing.
- Fit the impeller to the pump shaft. (if an existing impeller is re-used, install it in the same position as removed).

Maintenance

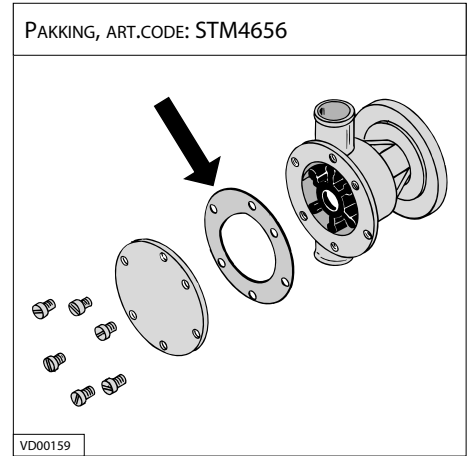

Replacing the pump cover

- Replace the cover with a **new** gasket.
- Check the water filter and open the sea cock.

Maintenance

Coolant replacement

The coolant has to be replaced every 1000 operating hours or at least once every two years.

N.B. Replacing the coolant may also be necessary as part of the winter storage procedure; in case that the coolant present in the cooling system offers insufficient protection for the winter.



DANGER

Be aware of the risk of skin burning during draining the hot coolant! Used coolant must be collected in a container for proper disposal according to laws and regulations.



Draining of coolant

- Remove the drain plugs from the engine block (1) and heat exchanger (2).
- Remove the filler cap to vent the cooling system and check that all the coolant has been drained.
- After draining replace the drain plugs.

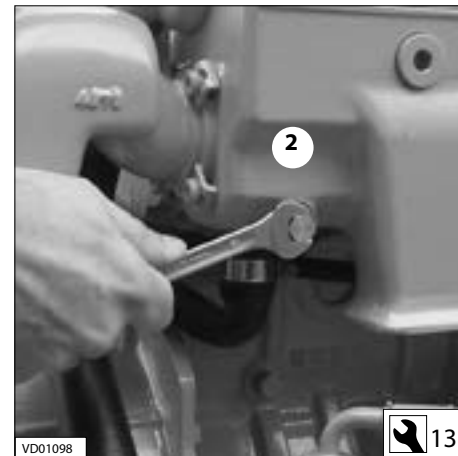

Coolant replacement

Every 1000 operating hours.

Coolant replacement

Every 1000 operating hours.

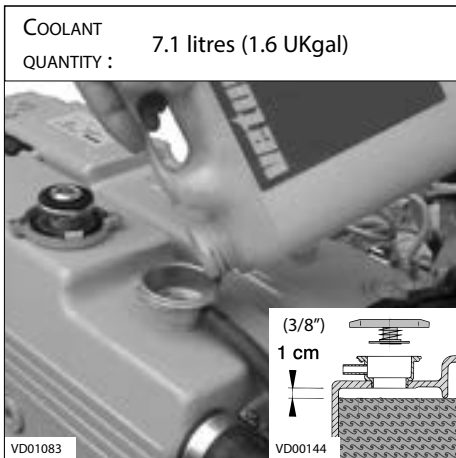

Filling the cooling system

Remove the cap of the filler neck on the top of the heat exchanger housing.

Remove plug A, so that air can escape from the cooling system.

Fill the cooling system.

Replace plug A as soon as coolant flows out.

Use a mixture of 40% antifreeze (ethylene-glycol based) and 60% tap water or use a special coolant.

For specifications see page 68.

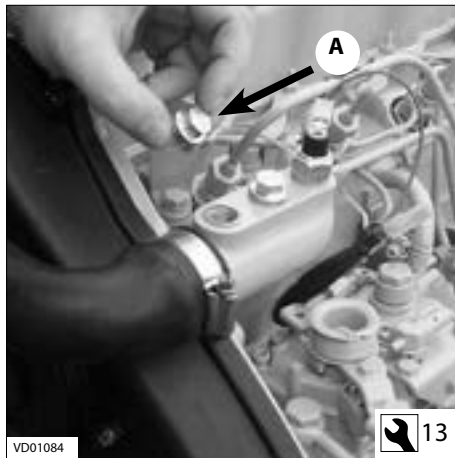

The level of the coolant must be approx. 1 cm (3/8") below the lower edge of the filler neck. Bleeding will take place automatically during filling!

Replace the filler cap.

After the engine has run for the first time and has reached operating temperature and has cooled down again to ambient temperature, check the coolant level in the heat exchanger housing.

Maintenance

WATER HEATER

If a water heater is connected to the engine and this heater is positioned above the upper side of the engine then bleeding of the heater will not take place automatically! Fill the heater separately to bleed the cooling system completely.

If necessary, add coolant.



CAUTION

Never fill the cooling system with sea water or brackish water.

Maintenance



Remove the drain plug

- Close the seacock and detach the water inlet hose from the sea water pump.
- Drain the coolant: To do this, remove the drain plug from the heat exchanger housing.



- Remove the filler cap from the top of the heat exchanger housing to allow air into the system and check that all coolant has drained off.

Cleaning the heat exchanger



Removal of exhaust injection bend

- Remove the 4 bolts of the exhaust injection bend.

Cleaning the heat exchanger

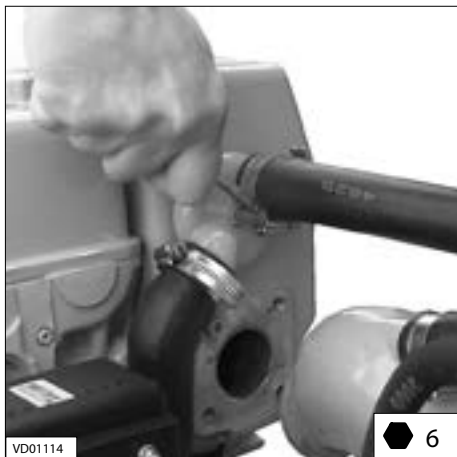

Removal of bolts out of the end covers

Take out both central bolts from the end covers and take the end covers with the O-rings out of the housing.



Maintenance

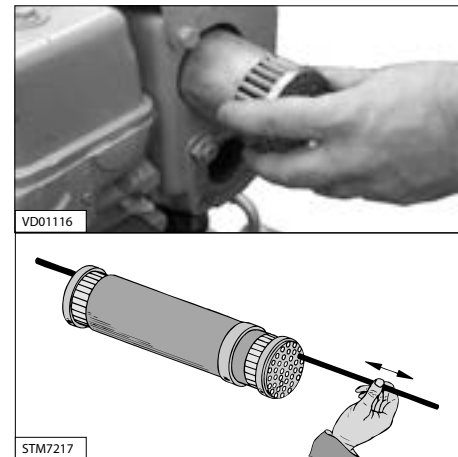

Cleaning the heat exchanger

Slide the heat exchanger out of the housing.

- Clean the heat exchanger: Use a pipe cleaner to remove fouling in the pipes.
- Then rinse the heat exchanger pipes with clean water.
- Ensure that both heat exchanger end chambers are free from dirt.

Maintenance

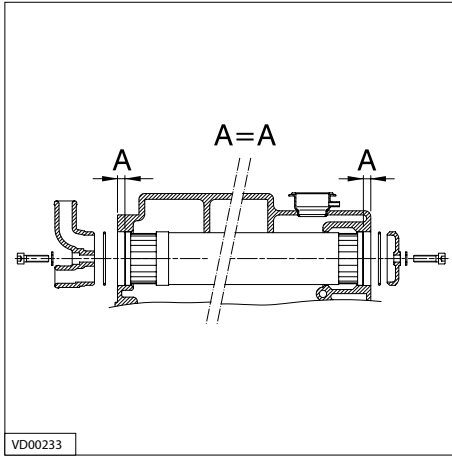

Replacing heat exchanger

- Replace the heat exchanger in the original position in the heat exchanger housing.

Use new O-rings (61 x 2.5 mm) which have been greased.

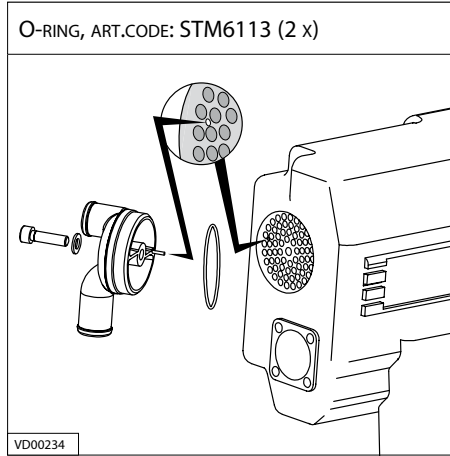

Replacing the end covers

Fit the end covers in the housing; the connector cover is fitted with a locating pin so that it can be fitted in one way only in relation to the heat exchanger.

This ensures the correct position of the separator baffle in the connector cover in relation to the heat exchanger.

Cleaning the heat exchanger

Tighten up the bolts when both covers are in the correct position.

- Refit the drain plug.
- Refit the exhaust injection bend.
- Reconnect all hoses previously removed.
- Refill the cooling system, see page 47.

Checking engine speed



WARNING

The maximum engine speed adjustment screw has been correctly set at the factory and sealed. DO NOT attempt to remove this seal.

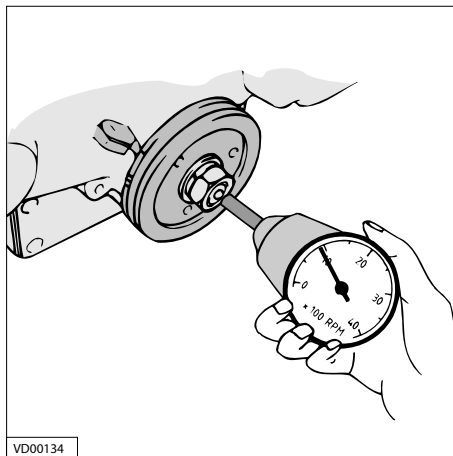

Checking engine speed

At full load (with the boat cruising) the maximum engine speed should be about 3000 resp. 4000 RPM (see technical data page 64). If the engine does not reach this speed, it is being overloaded! If this is the case, check the ship's propeller for defects or irregularities, and also to see that it is the correct pitch and diameter.

The engine idling speed should be 850 rpm.

- Allow the engine to warm up normally (until the coolant temperature reaches at least 60°C (140°F).) before checking and/or adjusting the idling speed.
- Check the engine RPM using a rev. counter, or use the rev. counter fitted to the control panel.

Maintenance

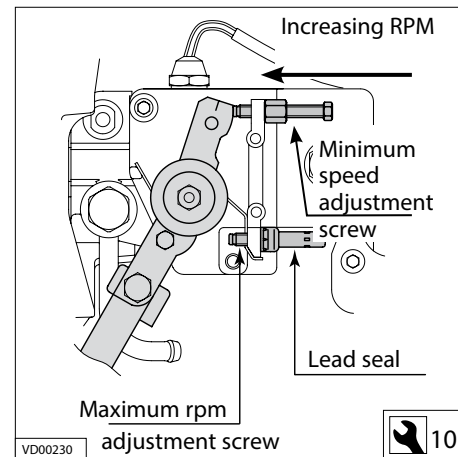

Adjusting engine idling speed

If the engine speed differs from that stated above, it must be adjusted. The engine idling speed can be reset using the adjustment screw on the fuel pump.

Winter lay-up



Fuel system

- Drain the water from the water separator/ fuel filter and the fuel tank.

Ensure that the tank is completely filled with fuel.

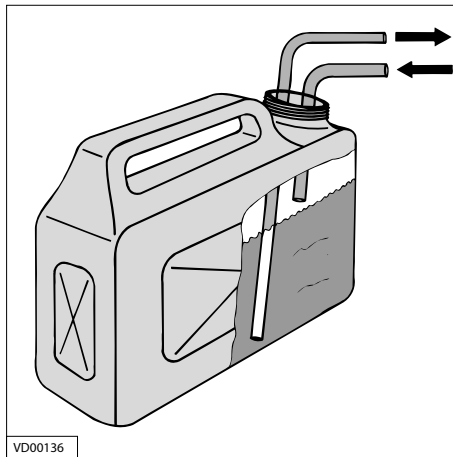

Running with protective fuel mixture

- Connect the fuel supply pipe to a can filled with a mixture of one (1) part of engine oil* to nine (9) parts of clean fuel**.
- Use this mixture to run the engine at **no load** for approx. 10 minutes.
- Stop the engine.

Winter storage procedure

* Engine oil with protective properties.
E.g. Shell Super Diesel T 10W40

** Preferably water-free fuel.
Collect some fuel from the return pipe,
while engine is running.



Never run the engine under load with this mixture of fuel and oil.

Winter storage procedure

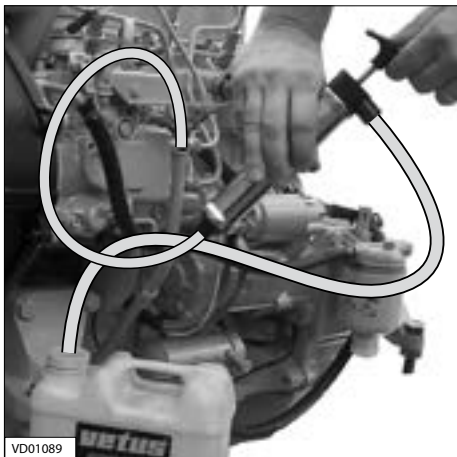

Lubrication system

With the engine still at operating temperature: (If not, run the engine until warm, then turn off.)

- Replace the oil filter and change the engine oil; use oil with protective properties. See page 66.

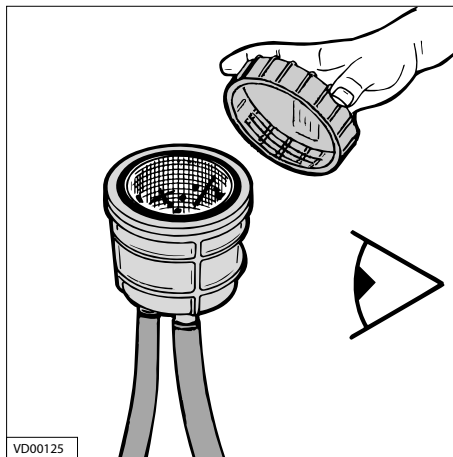

Raw water cooling system

- Close the seacock before removing the lid of the water strainer. If necessary, clean the raw water strainer.
- Pour 1 litre (2 UK pt) of anti-freeze into the water strainer and run the engine until the anti-freeze has disappeared into the cooling system.
- Take care that no anti-freeze is spilled into the waterway (anti-freeze is poisonous).

Winter lay-up

- Check the seal between the lid and housing after cleaning and re-assembling the strainer.

An improperly sealed lid will result in air sucked in by the raw water pump which again will result in overheating of the engine.

Winter lay-up



Fresh water cooling system

To avoid corrosion during winter storage the cooling system must be filled with an antifreeze/water mixture (or a coolant). For specifications see page 68.

N.B. Replacing the coolant is only necessary if the coolant present in the cooling system offers insufficient protection for the winter. For coolant replacement see page 46.

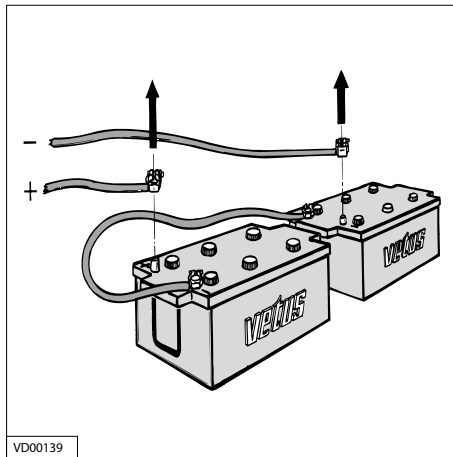

Electrical system

- Disconnect the battery cables.

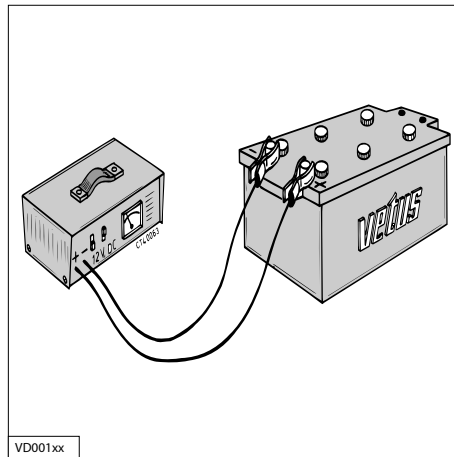

Charging the batteries

- Charge batteries during winter lay-up regularly if required!

Recommissioning after winter storage

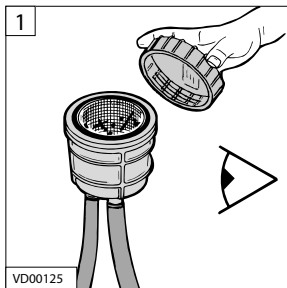

Check that the lid of the raw water strainer is reinstalled.

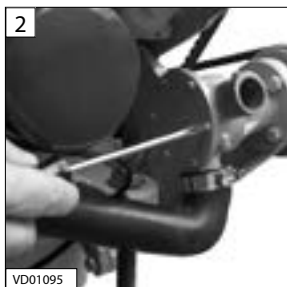

Check that the lid of the raw water pump and drain plugs are reinstalled. (pages 44, 46)

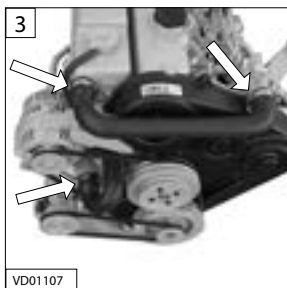

Re-tighten possible loose hose clamps.

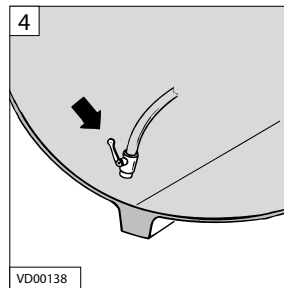

Open the sea cock.



Check the coolant level. (page 26)

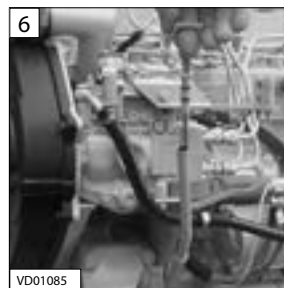

Check the engine oil level. (page 25)

Winter lay-up

Winter lay-up

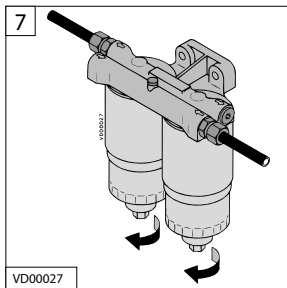

Drain the water from the water separator/fuel filter. (page 28)

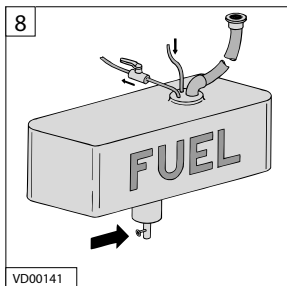

Drain the water from the fuel tank.



Install a new fuel filter. (page 36)

Recommissioning after winter storage

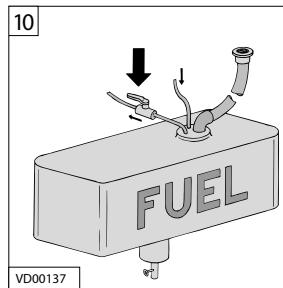

Open the fuel valve.

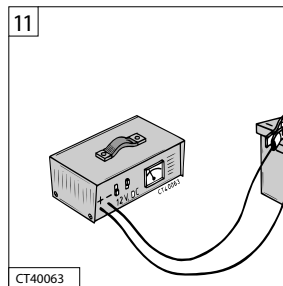

Make sure that the batteries are fully charged. (pages 30, 54)

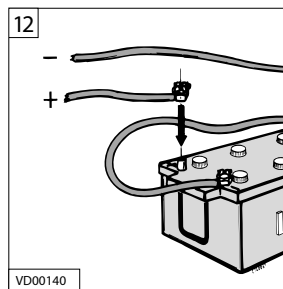

Connect the batteries.

Recommissioning after winter storage

Winter lay-up

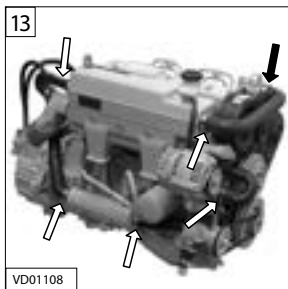

Start the engine.
Check the fuel system, the cooling system and the exhaust for leakage.

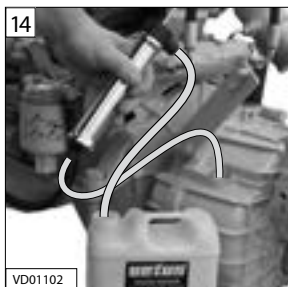

Stop the engine and change the oil of the gearbox. (page 35)

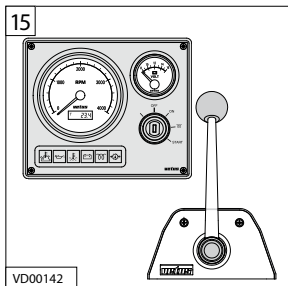

Check the operation of the instruments, the remote control and the gearbox.

Engine faults are in most cases caused by improper operation or insufficient maintenance.

In case of a fault, always check first that the operation and maintenance instructions have been followed.

In the following tables information is given about the possible causes of faults and suggested remedies. Please note that these tables can never be complete.

If you are unable to identify the cause of the fault or to rectify it yourself, then contact the nearest service representative.



DANGER

Before starting, make sure that nobody is in the immediate vicinity of the engine.

When carrying out repair, **never** start the engine with the fuel injection pump removed.

Disconnect battery!

Fault finding table

1 Engine will not crank

Possible fault	Remedy
Faulty or discharged battery.	Check / recharge battery and check engine alternator and/or battery charger.
Loose or corroded connections in starting circuit.	Clean and tighten connections.
Faulty starter-switch or faulty starter-relay.	Check / replace.
Faulty starter-motor or pinion does not engage.	Check / replace starter-motor.
Starter relay is not engaged due to a voltage too low; caused by a very long intermediate cable from engine to control panel.	Install an auxiliary starter relay.

Troubleshooting

2 Engine cranks but will not start, no smoke from exhaust

Possible fault	Remedy
Fuel stop valve closed.	Open.
(Nearly) Empty fuel tank.	Refill.
Air in fuel system.	Check and bleed.
Fuel filter clogged with water and/or contamination.	Check or replace
Leaking fuel supply line or fuel injection line.	Check / replace.
Faulty injector/injection pump.	Check, replace if required.
Vent line of fuel supply tank clogged.	Check / clean.
Exhaust restricted.	Check.
Electric fuel lift pump doesn't operate.	Check / replace.
Delivery and suction valves of electric fuel lift pump obstructed by dirt.	Check / clean. Install a fuel pilot filter in fuel line from tank to engine.
Clogged filter of electric fuel lift pump.	Check / clean.

Troubleshooting

Fault finding table

3 Engine cranks but will not start, smoke from exhaust

Possible fault	Remedy
Air in fuel system.	Check and bleed.
Faulty injector/injection pump.	Check, replace if required
Setting of stop valve incorrect.	Check / adjust.
Faulty glow plugs.	Check / replace.
Incorrect valve clearance.	Adjust.
Incorrect injection timing after overhauling of engine.	Check / adjust.
Insufficient intake air.	Check.
Wrong fuel quality or contaminated fuel.	Check fuel. Drain and flush fuel tank. Replace with new fuel.
Incorrect lube oil SAE class or quality for ambient temperature.	Replace.

4 Engine starts but runs unevenly (rough idling) or stalls

Possible fault	Remedy
(Nearly) Empty fuel tank.	Refill.
Air in fuel system.	Check and bleed.
Fuel filter clogged with water and/or contamination.	Check or replace.
Leaking fuel supply line or fuel injection line.	Check / replace.
Faulty injector/injection pump.	Check, replace if required.
Vent line of fuel supply tank clogged.	Check / clean.
Fuel supply line restricted.	Check / clean.
Incorrect valve clearance.	Adjust.
Idle setting too low.	Check/ adjust.
Exhaust restricted.	Check.
Wrong fuel quality or contaminated fuel.	Check fuel. Drain and flush fuel tank. Replace with new fuel.
Clogged filter of electric fuel lift pump.	Check / clean.

Fault finding table

5 Engine does not reach maximum rpm under load

Possible fault	Remedy
Air in fuel system.	Check and bleed.
Fuel filter clogged with water and/or contamination.	Check or replace.
Leaking fuel supply line or fuel injection line.	Check / replace.
Faulty injector/injection pump.	Check, replace if required.
Oil level too high.	Lower level.
Incorrect valve clearance.	Adjust.
Exhaust restricted.	Check / clean.
Insufficient intake air.	Check.
Wrong fuel quality or contaminated fuel.	Check fuel. Drain and flush fuel tank. Replace with new fuel.
Engine overloaded.	Check size of propeller.

Troubleshooting

5 Engine overheats

Possible fault	Remedy
Faulty injector/injection pump.	Check, replace if required.
Oil level too high.	Lower level.
Oil level too low.	Increase level.
Faulty oil filter.	Replace.
Coolant pump defective.	Check / clean.
Heat exchanger dirty or clogged as a result of rubber particles from a worn impeller.	Check / clean.
Coolant level too low.	Check / top up.
Sea cock closed.	Open.
Raw water strainer clogged.	Check / clean.
Leaking raw water intake system.	Check / replace.
Faulty thermostat.	Check / replace.
Faulty impeller raw water pump.	Check / replace.
Insufficient intake air.	Check / replace air intake filter.
Motor becomes apparently overheated as a result of faulty temperature switch, sensor or meter.	Check / replace.

Troubleshooting

Fault finding table

7 Engine not firing on all cylinders

Possible fault	Remedy
Air in fuel system.	Check and bleed.
Fuel filter clogged with water and/or contamination.	Check or replace.
Leaking fuel supply line or fuel injection line.	Check / replace.
Faulty injector/injection pump.	Check, replace if required.
Fuel supply line restricted.	Check / clean.
Faulty glow plugs.	Check / replace.
Incorrect valve clearance.	Adjust.
Clogged filter of electric fuel lift pump.	Check / clean.
Faulty electric fuel lift pump.	Check / replace.

8 Engine has little or no oil pressure

Possible fault	Remedy
Oil level too low.	Increase level.
Excessive inclination of engine.	Check / Adjust.
Incorrect lube oil SAE class or quality for ambient temperature.	Replace.

9 Engine oil consumption excessive

Possible fault	Remedy
Oil level too high.	Lower level.
Excessive inclination of engine.	Check / Adjust.
Incorrect lube oil SAE class or quality for ambient temperature.	Replace.
Excessive wear of cylinder/piston.	Check compression; overhaul engine.
Insufficient intake air.	Check.
Engine overloaded.	Check size of propeller.

Fault finding table

10A Blue exhaust smoke (idling)

Possible fault	Remedy
Oil level too high.	Lower level.
Excessive inclination of engine.	Check / Adjust.

10B Black exhaust smoke (at load)

Possible fault	Remedy
Insufficient intake air.	Check.
Faulty injector / injection pump.	Check / replace if required.
Engine overloaded, max. rpm is not reached.	Check sizes of propeller.

Troubleshooting

10C White exhaust smoke (at full load)

Possible fault	Remedy
Air in fuel system.	Check and bleed.
Faulty injector/injection pump.	Check, replace if required.
Water in fuel system.	Check water separator.
Faulty glow plugs.	Check / replace.
Incorrect valve clearance.	Adjust.
Incorrect injection timing.	Check / adjust.
Wrong fuel quality or contaminated fuel.	Check fuel. Drain and flush fuel tank. Replace with new fuel.
Vapour in exhaust gases condenses as a result of very low ambient temperature	-

Technical data

Model	:	VH4.65	VH4.80
General			
Make	:	VETUS Hyundai	
Number of cylinders	:	4	
Based on	:	D4BB	
Type	:	4-stroke diesel, in-line	
Injection	:	Indirect	
Aspiration	:	Natural	
Bore	:	91.1 mm	
Stroke	:	100 mm	
Total displacement	:	2607 cm ³	
Compression ratio	:	22 : 1	
Idling speed	:	850 rpm	
Max. no. of revolutions at no load	:	4100 rpm	4700 rpm
Valve Clearances (cold)	:	Inlet 0.15 mm Exhaust 0.15 mm	
Weight (with standard gearbox)	:	240 kg (529 lbs)	245 kg (540 lbs)
Engine installation			
Max. installation angle	:	15 degrees backwards	
Max. athwartships angle	:	25 degrees continuously, 30 degrees intermittent	

Engine specifications

Model	:	VH4.65	VH4.80
Maximum Output			
at the flywheel (ISO 3046-1)	:	48 kW (65.3 hp)	59 kW (80.3 hp)
at the prop shaft (ISO 3046-1)	:	46.6 kW (63.4 hp)	57.2 kW (77.6 hp)
at no. of revolutions of	:	3000 rpm	4000 rpm
Torque.	:	170 Nm (17.3 kgm, 125 ft.lb)	
at no. of revolutions	:	2200 rpm	
Fuel consumption			
at no. of revolutions of 2500 rpm	:	260 g/kW.h (191 g/hp.h)	
Fuel System (Self-bleeding)			
Injection pump	:	Bosch model VE	
Injectors	:	Plug injector	
Opening pressure	:	130 bar (kgf/cm ²) (1885 psi)	
Firing order	:	1 - 3 - 4 - 2	
Injection timing	:	5° ± 1° ATDC	
Fuel filter element	:	STM3690	
Fuel lift pump	:	Suction height max. max. 1.5 m (5 ft)	
Fuel supply connection	:	for hose 8 mm (5/16") I.D.	
Fuel return connection	:	for hose 8 mm (5/16") I.D.	

Engine specifications

Model	:	VH4.65	VH4.80
Oil lubrication system			
Oil capacity, max.			
without oil filter	:	4.9 litres (1.1 UKgal)	
with oil filter	:	5.5 litres (1.2 UKgal)	
Oil Filter	:	STM4910	
Oil temperature insump	:	max. 130°C (266°F)	
Cooling system			
Capacity,			
Intercooler version	:	7.1 litres (1.6 UKgal)	
Keel cooler version	:	8.1 litres (1.8 UKgal)	
Thermostat	:	opening at 76°C (169°F) fully opened at 85°C (185°F)	
Coolant pump,			
Flow at max. engine rpm	:	140 l/min (31 UKgal/min)	
Total head keelcooler at max. flow	:	2 m Water (6' 7")	
Raw water pump,			
Flow at max. engine rpm	:	60 l/min (13.2 UKgal/min)	80 l/min (17.6 UKgal/min)
Total head at max. flow	:	2 m Water (6' 7")	
Impeller	:	STM4652	
Inlet connection	:	for hose 25 mm (1") I.D.	
Calorifier connection	:	engine 'OUT' 17 mm (11/16") engine 'IN' 22 mm (7/8")	

Technical data

Model	:	VH4.65	VH4.80
Exhaust system			
Exhaust diameter	:	60 mm	75 mm
Exhaust back pressure	:	at specified output max. 150 mbar (2.2 psi)	
Electrical System			
Voltage	:	12 Volt	
Alternator	:	14 Volt, 95 A	
Battery capacity	:	min. 70 Ah, max. 108 Ah	
Protection	:	Fuse 'ATO' 10 A	
Starter motor	:	2.0 kW	
V-belt			
Alternator/ coolant pump	:	STM4509	
Raw water pump	:	STM4523	
Timing-belts			
Timing-belt	:	STM4862	
Timing-belt balanger shaft	:	STM4852	
Gearbox			
			Reduction ratio
ZF Hurth:	model ZF25A	:	1,55 / 1,93 / 2,29 / 2,71 : 1
	model ZF25	:	1,97 / 2,8 : 1
Technodrive:	model TM345	:	1,54 / 2,0 / 2,47 : 1
	model TM345A	:	1,54 / 2,0 / 2,47 : 1

Operating media

Lubricating oil

Engine Lubricating Oil

Only use a recognised brand of oil for lubricating the engine.

Lube oils are differentiated according to their performance and quality class. In common use are specifications named after API (American Petroleum Institute) and CCMC (Committee of Common Market Automobile Constructors).

Approved API Oils : CD, CE and CF4

Approved CCMC Oils : D4, D5

As the viscosity of lube oil is dependent on temperature, the oil viscosity (SAE grade) should be selected according to the ambient temperature when the engine is started.

To avoid oil changes dictated by the seasons we advise one of the following multi-grade oils.

- SAE 10W40 for temperatures of -25°C up to +30°C
(-13°F up to +86°F)

- SAE 15W40 for temperatures of -20°C up to +35°C
(-4°F up to +95°F)

For example: VETUS Marine Diesel Engine Oil 15W40
Shell Rimula R4 15W40

Gearbox Lubricating Oil

Only use a recognised brand of oil for lubricating the gearbox.

ZF Hurth:

model ZF25A : 1.8 litres (3.2 UKpt) ATF*)

model ZF25 : 2.5 litres (4.4 UKpt) ATF*)

Technodrive:

model TM345 : 1.6 litres (2.8 UKpt) Engine oil SAE 20W40-CD

model TM345A : 1.6 litres (2.8 UKpt) Engine oil SAE 20W40-CD

Other brands of gearboxes:

See supplied owners manual for oil type and quantities.

*) ATF : Automatic Transmission Fluid;
Transmissie olie type A, Suffix A.

For example : VETUS Transmission Oil
Shell Donax T6
Gulf Synth

Fuel

Fuel Quality Grade

Use commercially available diesel fuel with less than 0.5% sulfur content. If the sulfur content is higher than 0.5%, the intervals between oil changes should be halved e.g. change oil every 250 hours. Don't use fuel with more than 1% sulfur!

The following fuel specifications / standards are approved:

- CEN EN 590 or DIN/EN 590 (under development)
- DIN 51 601 (Feb. 1986)
- BS 2869 (1988): A1 and A2
- ASTM D975-88: D1 and D2
- NATO Code F-54 and F75

The exhaust emission levels determined during certification by the supervising authority are always based on the reference fuel described by law.

Operating media

Winter-grade fuel

Waxing may occur at low temperatures, clogging the fuel system and reducing engine efficiency.

If the ambient temperature is less than 0°C (+32°F), winter-grade fuel -suitable down to -15°C (+5°F) - should be used. This fuel is usually available from filling stations well in advance of the cold months. Diesel fuel containing additives (Super Diesel) is often on sale as well, for use down to -20°C (-4°F).

Operating media

Coolant

Coolant fluid

The preparation and monitoring of coolant in inter-cooled engines is especially important because corrosion, cavitation and freezing can lead to engine damage. Use as coolant a mixture of a cooling system protective liquid (anti-freeze, ethylene glycol based) and tap water.

In tropical climates, where anti-freeze availability may be limited, use a corrosion inhibitor to protect the engine cooling system.

The concentration of the cooling system protective liquid in the coolant should not fall below/exceed the following limits:

Cooling system protective liquid (Anti-freeze)	Water	Protection against freezing to
max. 45 vol%	55%	-35°C (-31°F)
40 vol%	60%	-28°C (-18°F)
min. 35 vol%	65%	-22°C (-8°F)

The protective liquid concentration must be maintained under all circumstances. Therefore if coolant must be added always use the same mixture of anti-freeze and tap water.

Water quality for coolant preparation

Use preferably tap water.

If an other available fresh water is used; the values given below must not be exceeded.

Water quality	min.	max.
pH-value at 20°C (68°F)	6.5	8.5
Chloride ion content [mg/dm ³]	-	100
Sulfate ion content [mg/dm ³]	-	100
Total hardness [degrees]	3	12



CAUTION

Never use sea-water or brackish water.



WARNING



Cooling system protective liquids must be disposed of in accordance with environmental regulations.

Engine with panel model '20', '21', '22'

Wiring diagram

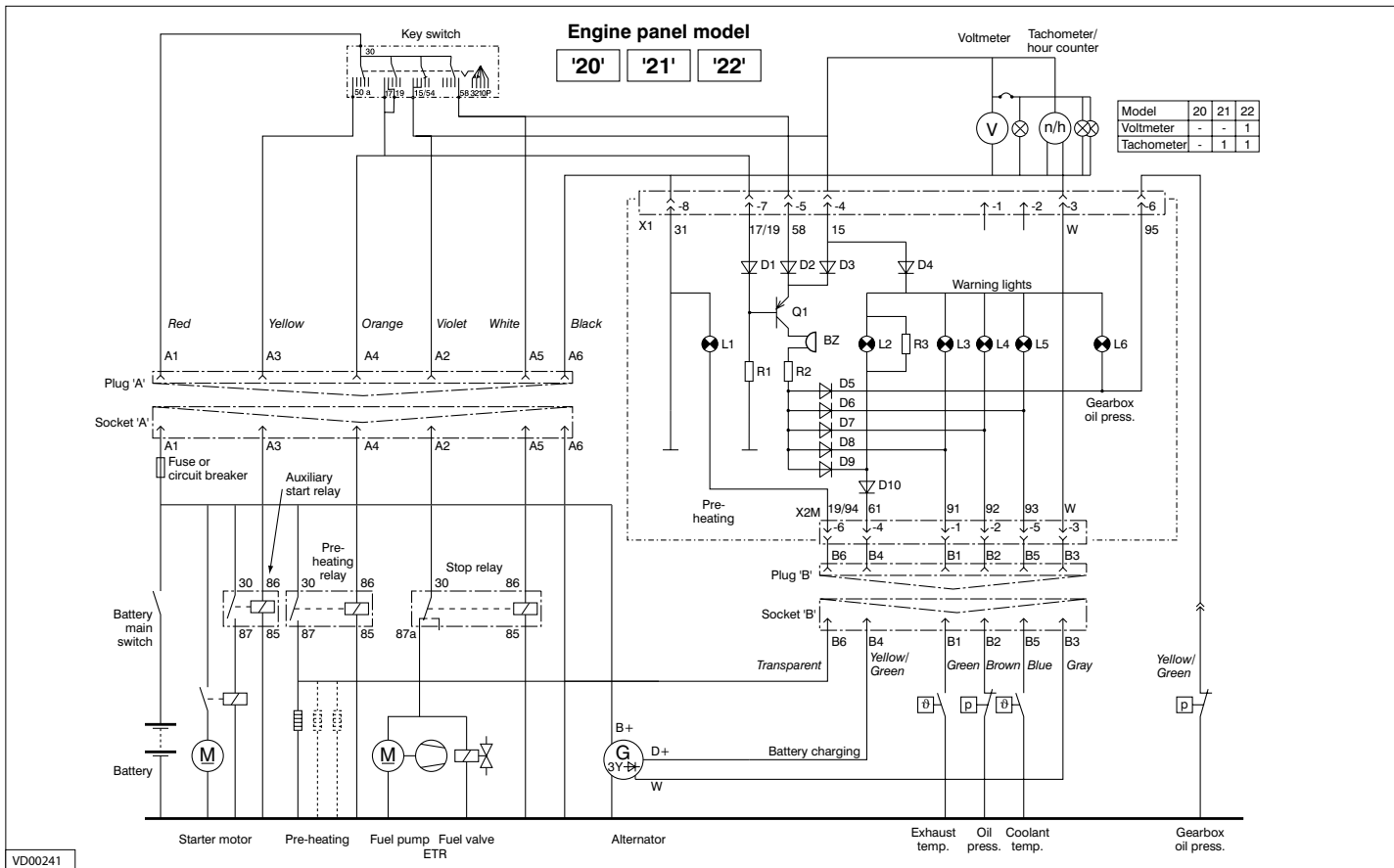

VD00241

Wiring diagram

Options, panel model '34'

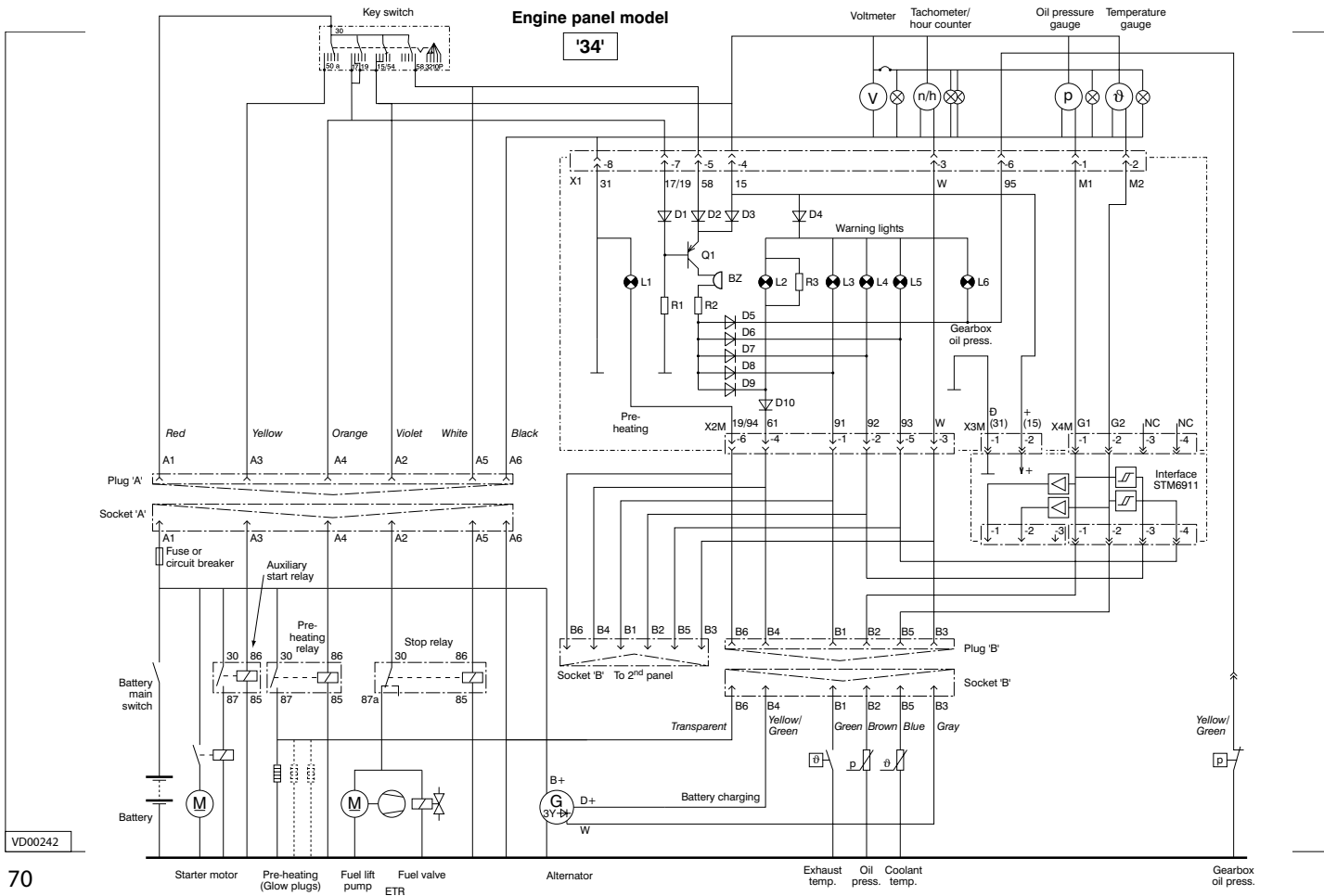

VD00242

Options, panel model '10'

Wiring diagram

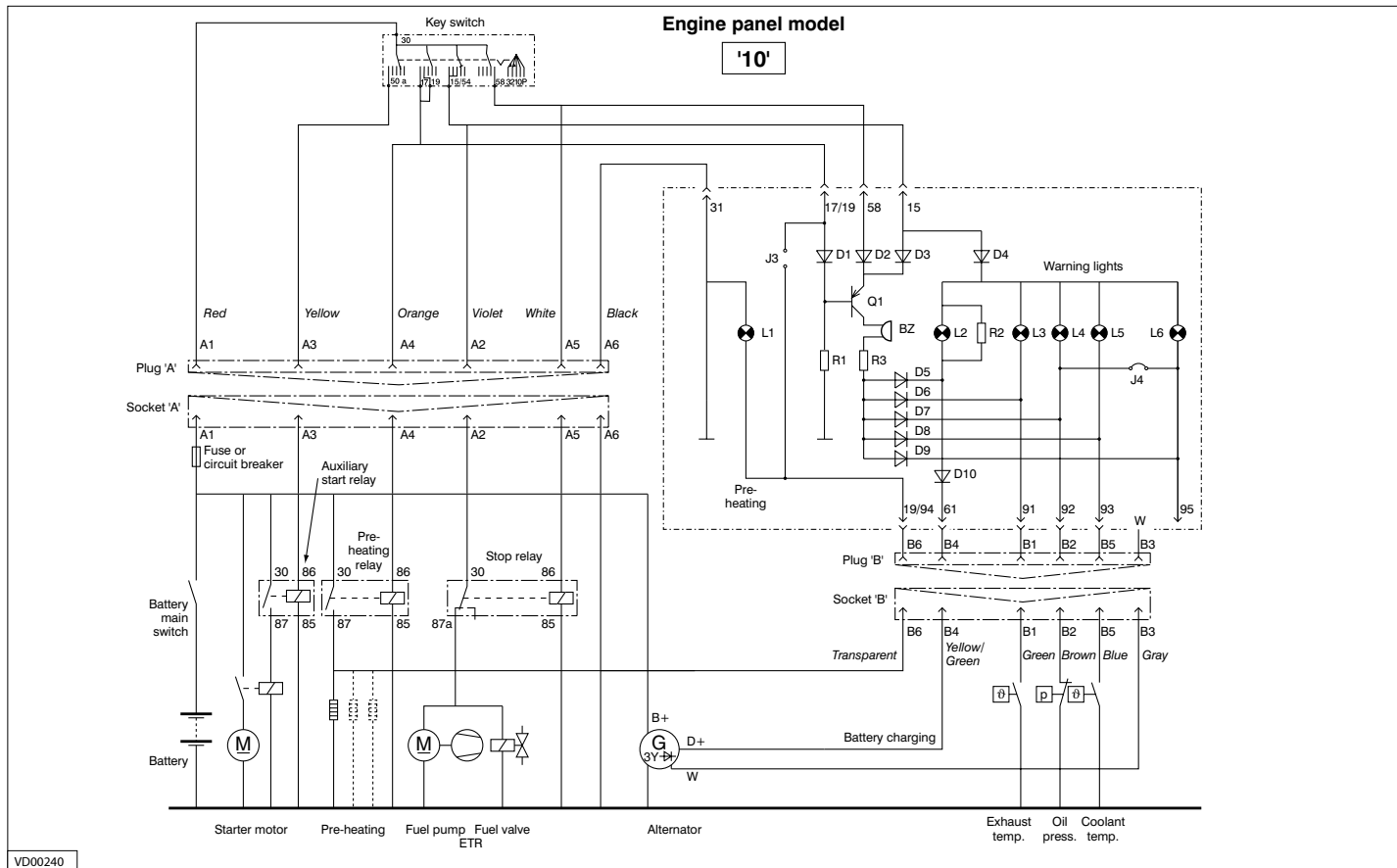

VD00240

Overall Dimensions

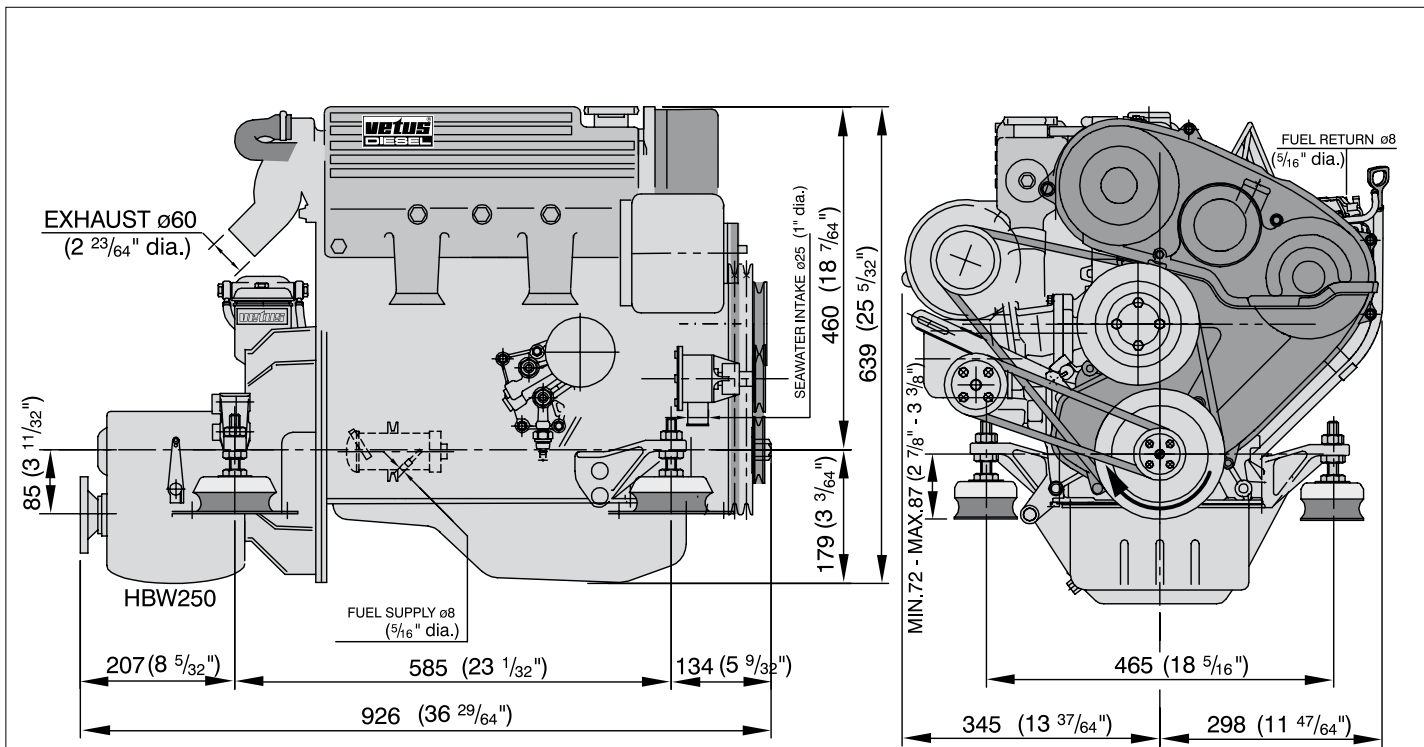

Vetus VH4.65

VD00235

1:10

Overall Dimensions

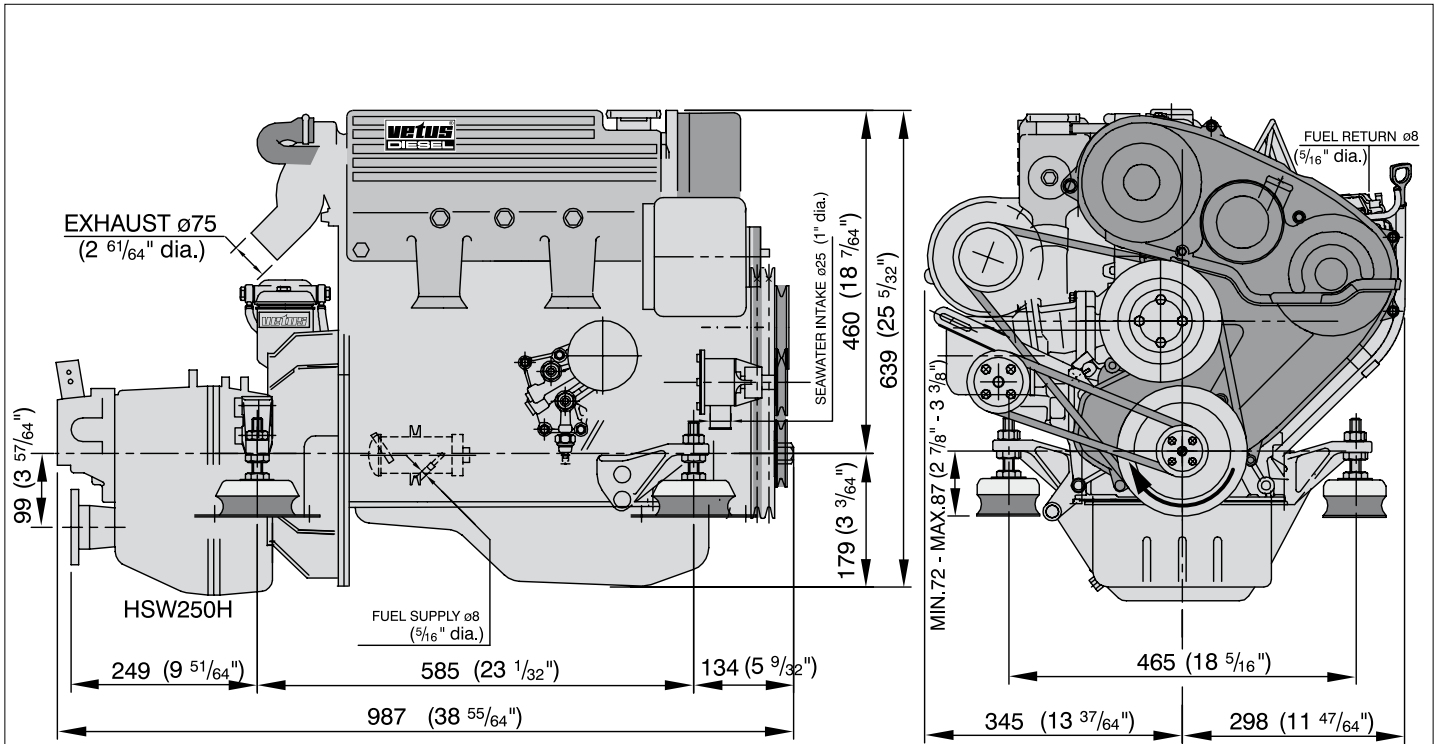

Vetus **VH4.80**

VD00236

1:10

A series of 15 horizontal dotted lines spanning the width of the page, providing a guide for handwriting practice.



Art. code	Description	
350101.01	(STM4993) Bedieningshandleiding VH4.65 / VH4.80	(Nederlands)
350102.01	(STM4994) Operation manual VH4.65 / VH4.80	(English)
350103.01	(STM4997) Bedienungsanleitung VH4.65 / VH4.80	(Deutsch)
350104.01	(STM4998) Manuel d'utilisation VH4.65 / VH4.80	(Français)
350105.01	(STM4999) Manual de operacion VH4.65 / VH4.80	(Español)
350106.01	(STM5000) Istruzioni per l'uso VH4.65 / VH4.80	(Italiano)
350107.01	Brugsanvisning VH4.65 / VH4.80	(Dansk)
350108.01	Användarmanual VH4.65 / VH4.80	(Svenska)
320331.01	(STM0032) Installatiehandleiding / Installation manual	(Nederlands / English)
320199.06	(STM0016) Service- en Garantieboek / Service and Warranty Manual / Service- und Garantieheft / Livret Garantie et Service / Manual de servicio y garantía / Libretto di assistenza e garanzia Service- og garantibog / Service- och garantihäfte	(Nederlands / English / Deutsch / Français / Español / Italiano / Dansk / Svenska)
351131.06	(STM4992) Onderdelenboek / Parts manual VH4.65 / VH4.80	(Nederlands / English)
352102.01	Service manual VH4.65 / VH4.80	(English)



Schiedam - Holland

Tel.: +31 (0)88 4884700 - sales@vetus.com - www.vetus.com