

VETUS[®]

HPCOOLER

Hydraulic marine propulsion

Oliefkoeler

Oil cooler

Ölkühlung

Refrigeriseur d'huile

Refrigerador del aceite

Refrigeratore olio

Installatie instructies

Installation instructions

Installationsvorschriften

Instructions d'installation

Instrucciones de instalación

Istruzioni per l'installazione

Hoofdafmetingen
Principal dimensions
Hauptabmessungen
Dimensions principales
Dimensiones principales
Dimensioni principali

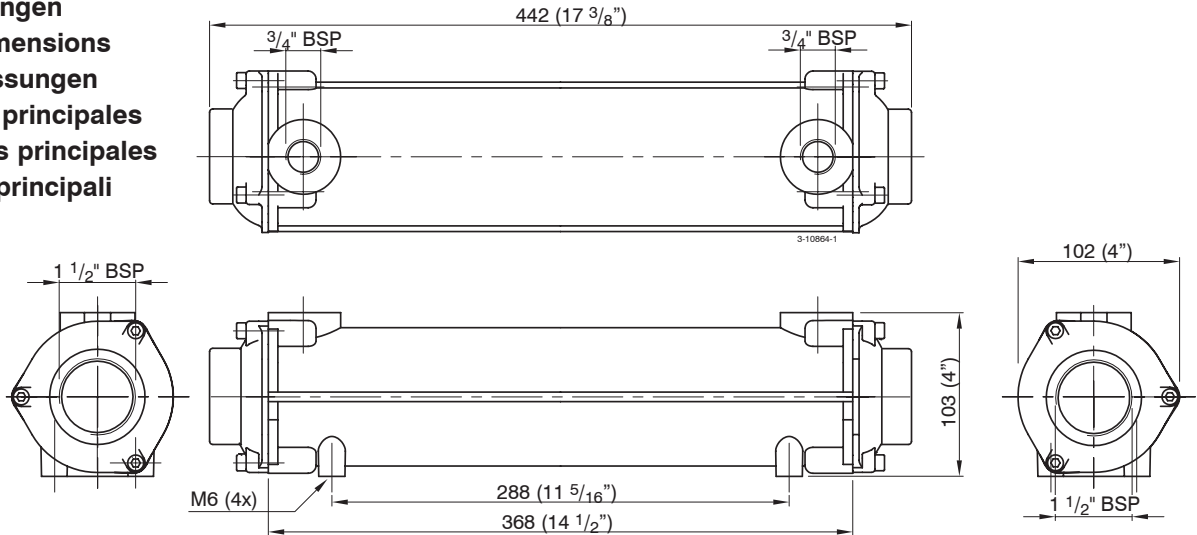

Technical data

Maximum oil flow	: 90 l/min (19.8 Imp Gal/min, 23.8 US Gal/min)
Maximum sea water flow	: 30 l/min (6.6 Imp Gal/min, 7.9 US Gal/min)
Internal oil volume	: 0.97 l (0.21 Imp Gal, 0.26 US Gal)
Internal water volume	: 0.71 l (0.16 Imp Gal, 0.19 US Gal)
Weight	: 4.8 kg (10.6 lbs)
Maximum working oil pressure	: 20 bar (290 psi)
Maximum working water pressure	: 20 bar (290 psi)
Maximum working temperature	: 120°C (250 F)
Seal	: nitrile
End covers	: bronze

Installatie
Installation
Installation
Instalación
Installazione

→ Olie
Oil
Öl
Huile
Aceite
Olio

→ Water
Water
Wasser
Eau
Acqua
Acqua

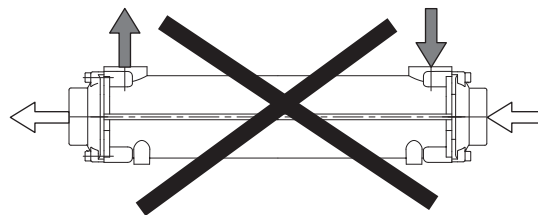
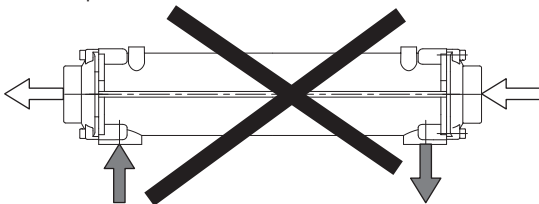
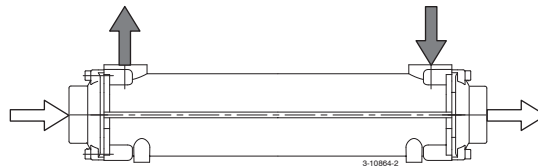
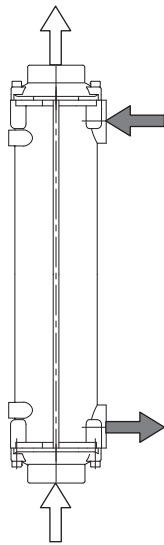

VETUS n.v.

FOKKERSTRAAT 571 - 3125 BD SCHIEDAM - HOLLAND - TEL.: +31 10 4377700
TELEFAX: +31 10 4372673 - 4621286 - E-MAIL: sales@vetus.nl - INTERNET: <http://www.vetus.com>

Printed in the Netherlands
120502.02 03-09