



DARTAGN1

ATHOS1

PORTOS1

Dekventilator
 Deckventilator
 Decksventilator
 Aerateur de pont
 Aireadores de cubierta
 Ventilatore di coperta

Breng een dunne laag afdichtingskit aan op de onderkant van de flens (1) en breng zuurvrije vaseline aan op de rubberen pakking (2).

Apply a thin layer of sealant to the underside of the flange (1) and apply acid-free vaseline to the rubber gasket (2).

Tragen Sie eine dünne Schicht Dichtungsmasse auf die Unterseite des Flansches (1) und säurefreie Vaseline auf die Gummidichtung (2) auf.

Appliquez une fine couche de mastic d'étanchéité sur la face inférieure de la bride (1) et appliquez une graisse à base de vaseline sans acide sur le joint en caoutchouc (2).

Aplique una fina capa de sellador en la parte inferior de la brida (1) y aplique vaselina sin ácido en la junta de goma (2).

Applicare un sottile strato di sigillante sul lato inferiore della flangia (1) e applicare della vaselina priva di acidi sulla guarnizione di gomma (2).

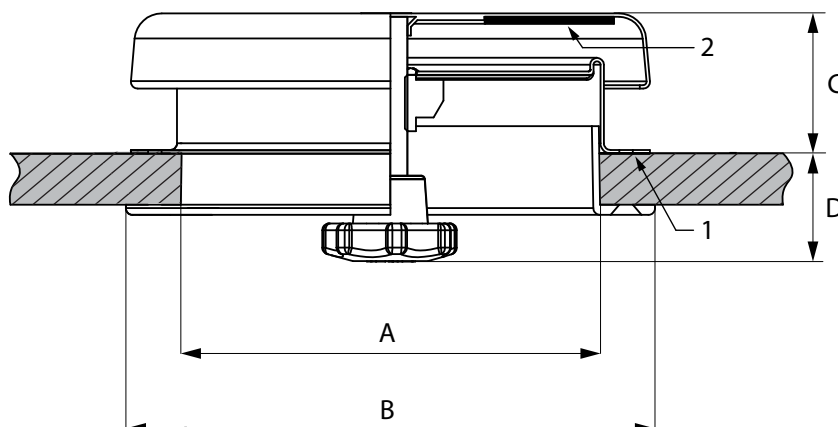
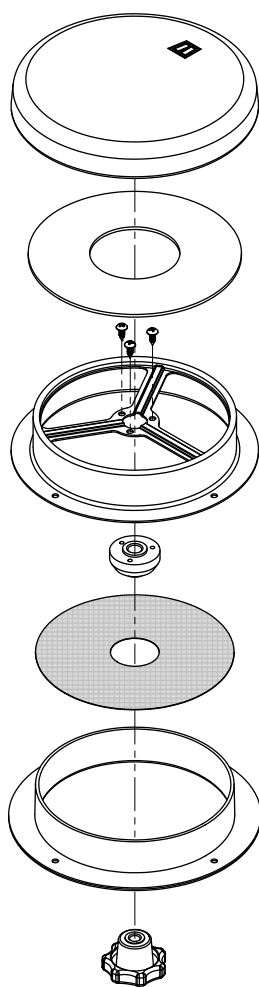

	A	B	C	D
DARTAGN1	Ø 147 (DIA 5 13/16")	Ø 185 (DIA 7 5/16")	36 - 53 (1 7/16" - 2 1/16")	32 - 49 (1 1/4" - 1 15/16")
ATHOS1	Ø 122 (DIA 4 13/16")	Ø 152 (DIA 6")	31 - 43 (1 1/4" - 1 11/16")	37 - 49 (1 7/16" - 1 15/16")
PORTOS1	Ø 85 (DIA 3 3/8")	Ø 117 (DIA 4 5/8")	31 - 45 (1 1/4" - 1 3/4")	27 - 41 (1 1/16" - 1 5/8")

Netto doorlaat - Net opening size - Nettodurchlaß
 Passage net - Conducto neto - Dimensioni retali relative

DARTAGN1	83 cm ² (12.9 sq. inch)
ATHOS1	52 cm ² (8.1 sq. inch)
PORTOS1	21 cm ² (3.3 sq. inch)



Schiedam - Holland
 Tel.: +31 (0)88 4884700 - sales@vetus.com - www.vetus.com