



## Electronic engine remote control



**EC4**



**EC4HSM**



# Contents

1	Introduction.....	6
1.1	How to start .....	6
1.2	System configuration and installer remarks .....	6
2	General installation features .....	7
2.1	Description of the system and its parts.....	7
2.2	Maximum extension of the system.....	7
2.3	System performance .....	7
3	Pilot instructions .....	8
3.1	Control keypad .....	9
3.2	Acquisition of the command.....	10
3.3	Engine Warm-up .....	10
3.4	Synchro mode .....	11
3.5	Fast Start-up Mode.....	11
3.6	Emergency lever .....	11
4	Command station .....	12
4.1	Dimensions .....	12
4.1.1	Command station EC3 .....	12
4.1.2	Command station EC4 .....	12
4.2	Friction adjustment .....	13
4.2.1	Command station EC3 .....	13
4.3	Programming of the command station.....	13
4.3.1	For command stations before serial number 18500.....	13
4.3.2	For command stations after serial number 18500 .....	14
4.3.3	EC4 two-engine stations: how to assign the Synchro function to the operating lever (after serial number 18500) .....	14
4.4	Command station label.....	15
4.5	Trolling option .....	15
4.6	Trim/Flap option .....	16
4.7	Advices about the mounting and preservation of the Command Station .....	17
4.8	Command station codes.....	17
5	Actuator .....	18
5.1	Drawing of actuators with mechanical interface.....	18
5.2	Drawing of full electronic actuator.....	19
5.3	How to mount the Actuator .....	19
5.4	Electronic Actuator Boards .....	20
5.4.1	Actuator board ver. 3.1 .....	20
5.4.2	Relays PCB version RB 1.0 for TRIM-FLAP and neutral relays .....	21
5.4.3	Relays PCB version 2.0 for electronic gearboxes .....	22
5.5	Actuator labels.....	23
6	Accessories and Options .....	24
6.1	CANBus cable.....	25
6.1.1	CANBus data transmission cable.....	25
6.1.2	CANBus extension cable .....	25
6.2	Cable for electronic engine .....	25
6.2.1	Cable for 1 electronic engine with 1 channel: voltage, PWM, 4-20 mA .....	25
6.3	Cable actuator – gearbox solenoid driven.....	26
6.3.1	Cable actuator - gearbox solenoid driven + neutral relay signal .....	26
6.4	Cable actuator – trim/flap .....	27
6.5	Cable actuator – Mercruiser® trim pump .....	28
6.6	T-Splitter.....	29
6.7	Power supply connector.....	29

7	Configuration of the CANBus network.....	30
7.1	Installation with 2 mechanical actuators – solution A.....	30
7.2	Installation with 2 mechanical actuators – solution B.....	31
7.3	Installation with 2 mechanical actuators – solution C.....	32
7.4	Installation with 1 actuator – solution D.....	33
7.5	Installation with 1 actuator – solution E.....	34
7.6	Configuration: end of line termination resistor and address setting of command stations and actuators.....	35
7.6.1	Configuration of the command station.....	35
7.6.2	Configuration of the actuator.....	37
7.7	Configuration with more than 3 command stations.....	38
8	Electrical installation.....	39
8.1	Wiring from the battery to the actuator (input cables).....	39
8.1.1	Supply connector.....	39
8.1.2	The ignition key switch.....	40
8.1.3	Electrical installation of systems with 1 engine, 1 actuator and 1 ignition key.....	40
8.1.4	Electrical installation of systems with 2 engines, 1 actuator and 2 ignition keys.....	41
8.1.5	Electrical installation systems with 1 engine, 1 actuator and 2 ignition keys.....	41
8.1.6	Electrical installation of systems with 2 engines, 2 actuators and 2 ignition keys.....	42
8.1.7	Electrical installation of systems with 2 engines, 2 actuators and 4 ignition keys.....	43
8.1.8	Dimensional criteria of the power supply cables.....	43
8.2	Wiring from the actuator to command stations, engines, gearboxes, trim/flaps, etc (output cables).....	44
8.2.1	Actuator with mechanical interface without neutral relay.....	44
8.2.2	Actuator with mechanical interface and neutral relay.....	45
8.2.3	Actuator with full electronic interface.....	46
8.2.4	Actuator with full electronic interface and neutral relay.....	46
8.2.5	Wiring scheme to gearbox in case of actuator without neutral relay.....	47
8.2.6	Wiring scheme to gearbox in case of actuator with neutral relay.....	47
8.2.7	Wiring scheme from actuator to trim/flap with external supply.....	48
8.2.8	Wiring scheme from actuator to trim/flap with internal supply.....	48
9	Programming of the actuator, general guidelines.....	49
9.1	Programming keypad.....	49
9.2	Display and Parameters.....	49
9.3	Actuator parameters.....	50
10	Installation of the push-pull cable and stroke's programming on the actuator.....	51
10.1	Push-pull cables choice.....	51
10.1.1	Connection kit.....	51
10.1.2	Standard push-pull cable.....	51
10.1.3	MerCruiser® stern drive push-pull cable.....	52
10.1.4	Johnson® push-pull cable.....	52
10.2	Mounting of the push-pull cables between engine and actuator.....	53
10.2.1	Connection of the push-pull cable to the engine.....	53
10.2.2	Connection of the push-pull cable to the actuator.....	53
10.3	Mounting of the push-pull cable between gearbox and actuator.....	56
10.3.1	Connection of the push-pull cable to the gearbox side.....	56
10.3.2	Connection of the push-pull cable to the actuator.....	56
11	Programming of the strokes on actuator with mechanical interface to engine and gearbox.....	59
11.1	Programming of the push-pull cable strokes.....	60
11.2	Sea trials.....	62
11.3	Specific parameters.....	63

12	Programming of actuators for installations with electronic engine and mechanical gearbox.....	64
12.1	Programming of the gearbox strokes .....	65
12.2	Sea trials.....	67
12.3	Specific parameters .....	69
12.3.1	Parameters to configure the voltage output signal for electronic engines .....	69
12.3.2	Parameters to configure the voltage output signals .....	70
13	Programming of actuators for mechanical engines and electronic gearbox .....	71
13.1	Mounting of the engine the push-pull cable and programming of throttle mechanical strokes... ..	71
13.2	Programming of the push-pull cable strokes .....	71
13.3	Electrical cabling of the gearbox.....	71
13.4	Specific parameters .....	71
14	Programming of actuators with electronic engine and electronic gearbox.....	72
14.1	Electrical wiring .....	72
14.2	Specific parameters .....	72
15	System configuration in case of options .....	73
15.1	Commissioning of actuators for installations with Trim or Flap command option .....	73
15.2	Commissioning of actuators for installations with Trolling option .....	73
15.3	Commissioning of the actuators with Neutral Relay option .....	73
16	Trouble shooting .....	75
16.1	What to do in case of system failure.....	75
16.1.1	Behaviour of the system in case of unforeseen shutdown.....	75
16.1.2	Emergency lever and how to overcome faults during navigation in case of system with mechanical interface .....	75
16.1.3	Self-protection in case of overload or breakage of the push-pull cables .....	76
16.2	Analysis of the electronic system behaviour.....	77
16.3	Diagnosis through the command station .....	79
17	Drilling mask for command stations.....	80
17.1	Command station series EC3 .....	80
17.2	Command station series EC4 .....	81
18	Drilling mask for actuator .....	82

# 1 Introduction

This manual describes the electronic remote control system in general and its operating, performance and safety aspects. If it is the first time that you install a VETUS electronic control system, go to the next section where you will be guided to the necessary steps.

## 1.1 How to start

Once you have received the system package, follow these steps:

- 1) identify all the components necessary to build up your system with the help of instructions at sections 4, 5, 6 and report all the relevant data in the frame here below
- 2) identify your installation type with the help of section 7.
- 3) configure the CANBus network, set dip-switches and end of line termination of actuators and command stations, as described at section 7.6
- 4) mount command stations and actuators with the help of drilling mask (section 17)
- 5) make electrical wiring (section 8)
- 6) install push-pull cables, if your application requires it (section 10)
- 7) make setting of mechanical strokes, if your application requires it (section 11, 12 and 13)
- 8) program the actuator specific installation parameters (from section 11 to section 16 included)
- 9) make the programming of the options, if your application requires it (section 15)
- 10) once you have set-up the electronic system, read the pilot's instruction (section 3). Good navigation!

## 1.2 System configuration and installer remarks

Component	Position aboard	Serial number
Command station 1		
Command station 2		
Command station 3		
Actuator left engine		
Actuator right engine		

Boat registration number	
Date of installation	
Name and signature of authorized installer	

## 2 General installation features

### 2.1 Description of the system and its parts

The electronic engine remote control implements mechanical and electronic solutions with digital communication technology. Only few devices are required to compose a complete electronic engine remote control:

- Command stations
- Actuators
- Data communication cables which connect the Command Stations to the Actuators

### 2.2 Maximum extension of the system

The maximum configuration of the system is as shown in the following table:

Actuators	The maximum number of engines that the system can control is 2
Command stations	The maximum number of Command Stations is unlimited
80 meters	Maximum distance between cockpit and engine room

### 2.3 System performance

#### Temperature

Operating temperature	From -10 to 85°C
Storage temperature	From -40 to 90°C

**Humidity max operating limit:** 90% (relative humidity)

#### Protection degree of main system components

Command Station series EC3	IP 66
Command Station series EC4	IP 67
Actuator	IP 54

#### Mechanical features

Nominal load when actuator is providing a pushing force	150 N (15 kg) with power consumption 1.5 A
Max load when actuator is providing a pushing force	450 N (45 kg) with power consumption 5 A (with time <1 s)
Stroke of gearbox – forward	Stroke can be set between 15 and 40 mm
Stroke of gearbox – reverse	
Throttle stroke	Stroke can be set between 30 and 80 mm

#### Electrical features

Power supply	from 9 to 28 Vdc (for standard installations) from 20 to 28 Vdc(for special installations)
Max. current absorbed	5 A
Current absorbed when the system is in standby	0,5 A

### 3 Pilot instructions

In the VETUS electronic control system can be mounted any of the following command stations: EC3- EC4. Depending on the system configuration and on the type of command station, the latter can be used for the command of one or two engines. Here below are reported the instructions for some types of levers: although the functions are the same, due to the command station's construction, push buttons, LEDs and keypads might look slightly different. For more detailed information look at the specific command station product instruction.

Each command station repeats the functionality of a traditional mechanical lever. Moving the lever from the neutral position, after an angle between 16° and 20° forward or reverse (it depends on the lever's type), automatically the electronic system clutches-in respectively the forward or reverse gear. It follows then the lever's stroke in forward and backward direction for the throttle control.

#### Command station EC3

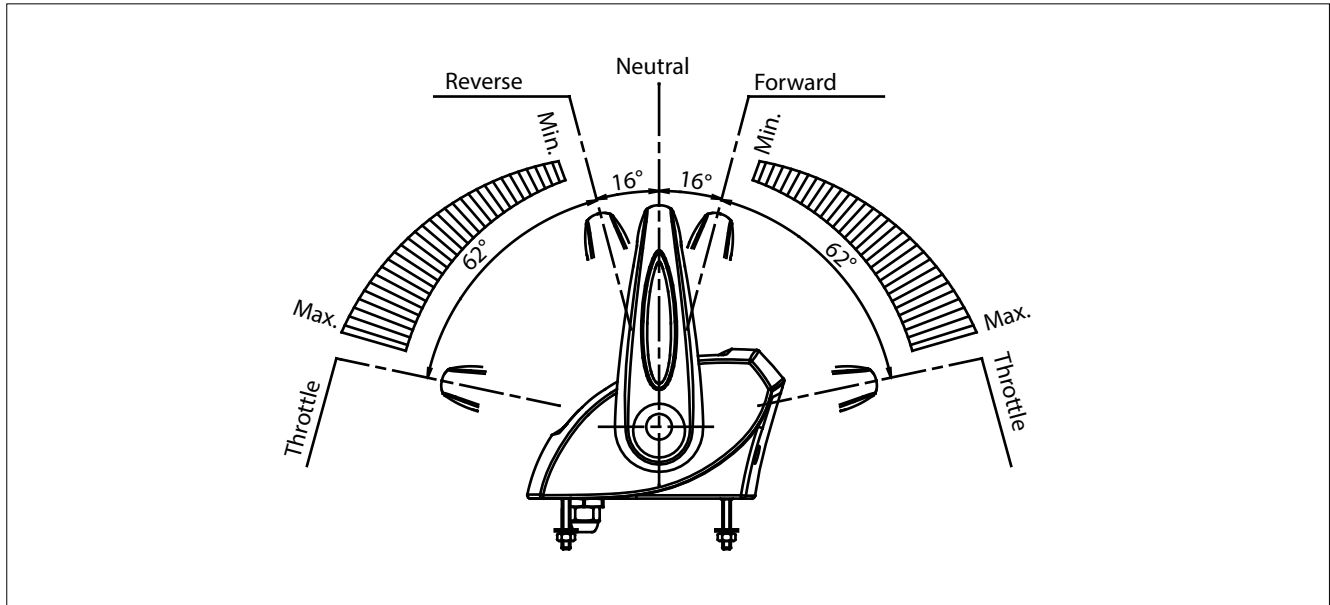

#### Command station EC4

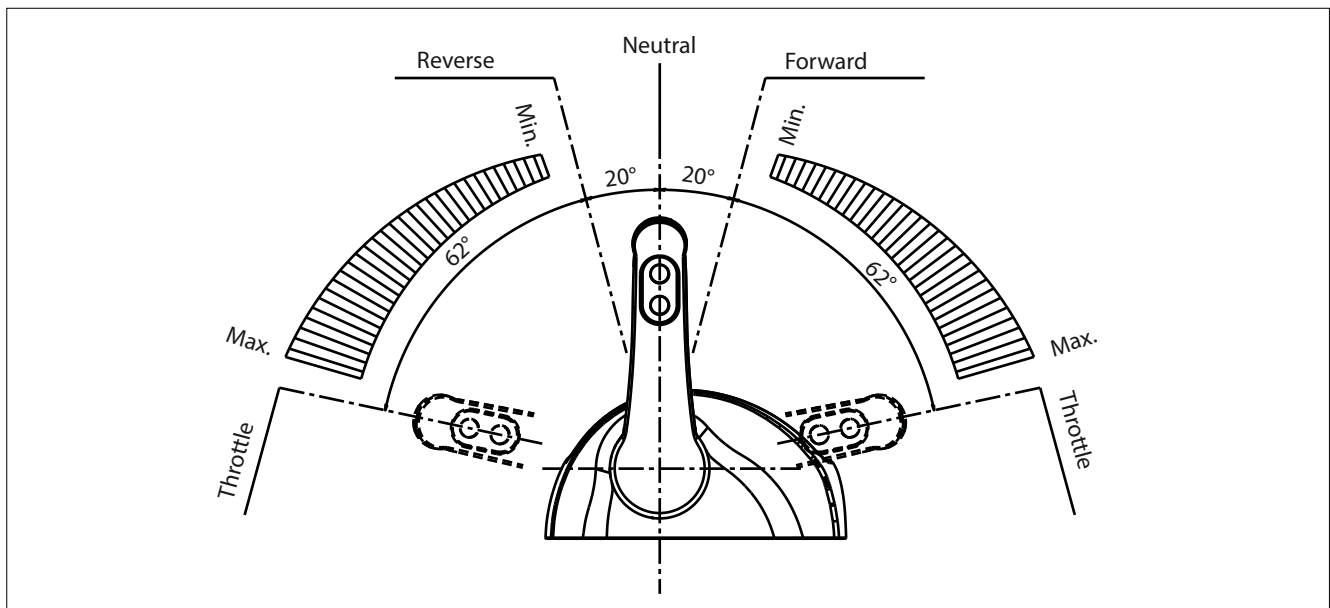



### 3.1 Control keypad

On each command station are mounted an electronic keypad, push-buttons and LEDs.  
 In installations with single engine(\*), both the green LEDs are referring to the same engine. In systems with 2 engines the push button and the green LED on the right are referring to the starboard engine while the push button and the green LED on the left side are referring to the port engine.

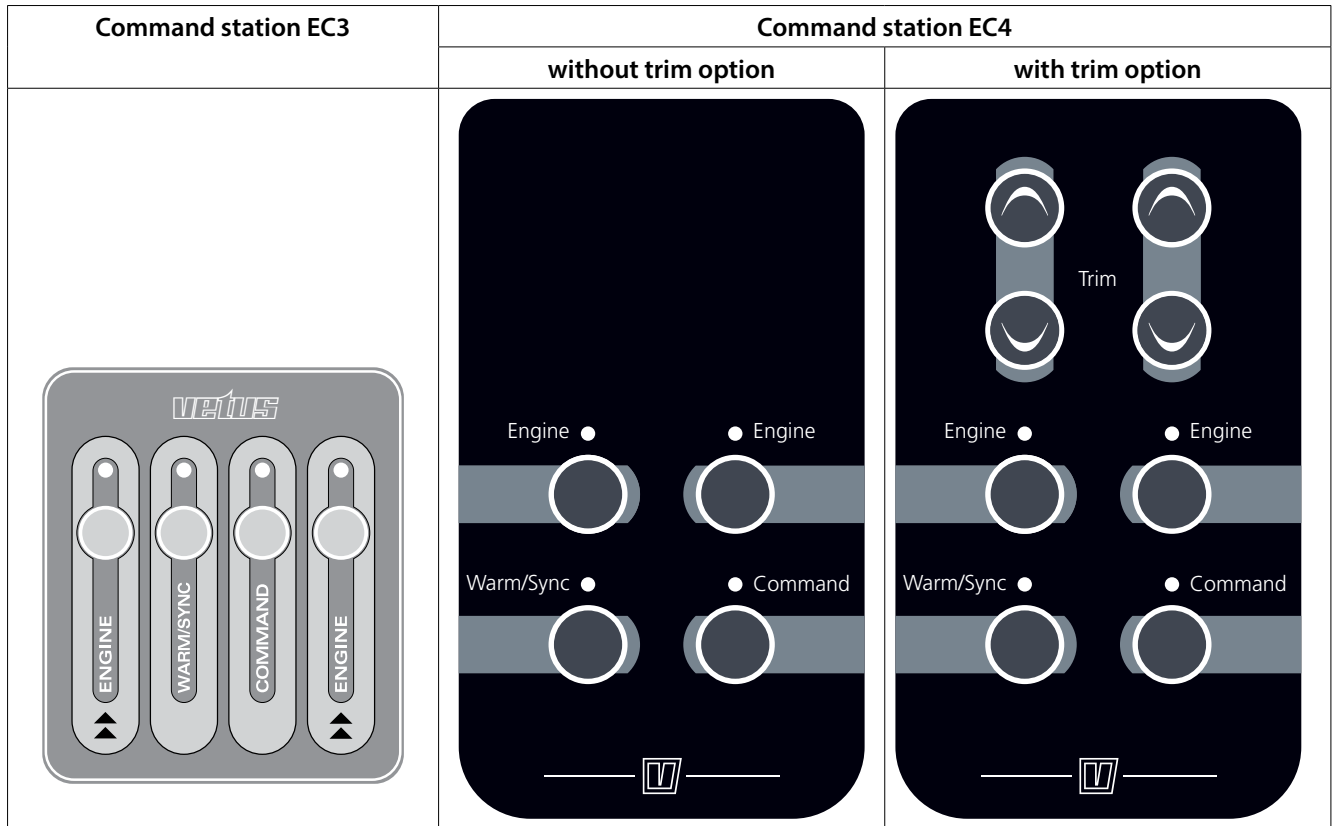

Description	LEDs colour
Engine (*)	Green
Warm/Sync	Yellow
Command	Red
Engine (*)	Green

(\*) In installations with single engine, both the green LEDs are referring to the same engine. In systems with 2 engines the push button and the green LED on the right are referring to the starboard engine while the push button and the green LED on the left side are referring to the port engine.

It follows the table with the definition of LED and push buttons.

Push-button	LED	Description
	Engine	The left LED is for the port (left) engine, while the right LED is for the starboard (right) engine. If the LED has a fixed light on (green), the corresponding gearbox is in neutral position. If the LED is blinking (green), the lever on the LED's side is synchronised with the lever of the station that at the moment has the Command.
	Command	If it is switched off, the Station has not the command. If is switched on, the Station has the command.
	Warm/Sync	If it is blinking, the navigation system is in Warm-up mode; this means that the engines can be accelerated without clutching-in the gear. If the LED is fix lighted, the system is in Synchro mode.
Warm/Sync		When both the levers of the Station that has the command are in neutral position, if you press for 1,5 seconds the button Warm, it is activated the function Warm-up.
Command		If you press Command for 1,5 seconds the station takes the command, only if one of these two conditions are respected: <ul style="list-style-type: none"> <li>- both the lever of the station are in neutral</li> <li>- both the lever are synchronized with respect to the levers of the station that at the moment has the command</li> </ul>
All LEDs are lighted on		The control system isn't working correctly

### 3.2 Acquisition of the command

It is possible to acquire the command of the boat from any Station in the following cases:

- **The boat isn't moving**

1. Position both the levers in neutral and press Command for 1,5 seconds.
2. LED "Command" is now lighted on while the warm/synch LED is blinking. You are in Warm-up mode: throttle command is enabled but clutch command is disabled.
3. To enable the command of the gearbox you must press for 1,5 seconds the Warm/Sync push-button

- **In navigation**

1. Synchronize the 2 levers of the Station which wants to acquire the command with respect to the Station which has the command.
2. When LEDs "Engine" of the station which wants to acquire the command are blinking, these levers are synchronised with the levers of the station which still has the command.
3. By pressing the pushbutton Command for 1,5 seconds, the new station takes the command.

**Important:** before taking the command, proof that all the passengers are safely on board.

### 3.3 Engine Warm-up

If both levers are in neutral, by pressing for 1,5 seconds the button Warm/Sync of the Station which has the command, you enter in Warm-up mode. If you move the lever, it is only affected the accelerator but not the gear.

In Warm-up mode the LED Warm/Sync is blinking.

After positioning again both levers in neutral and pressing for 1,5 seconds the Warm/Sync, the system comes back to the normal operation mode.

### 3.4 Synchro mode

It is possible to command both engines at the same speed and direction with only one lever. This function can be activated only by the station which has the command.

With both levers in neutral position, press at the same time for 1,5 seconds the two "engine" push-buttons. The command of both engines is now on the right lever. In Synchro operation mode, the LEDs "Warm/Sync" and "Command" are lighted on.

From "Synchro" operation mode, if you position both levers in neutral, and press contemporaneously for 1,5 seconds the two "Engine" push buttons, the command of each engine is again assigned to the respective lever and LED "Warm/Sync" is switched off.

Synchronisation or de-synchronisation can be performed on the station which has the command, in case the RPMs between the two engines don't differ more than 10%.

### 3.5 Fast Start-up Mode

This function is available on the first command station as described in section 7.6 of this manual. When the configuration FSM (Fast Start-up Mode) is enabled, the station with the FSM enabled, takes automatically the command at the power on, only if both its levers are in neutral position.

If the station is not in neutral position, it will take the command as soon the neutral position will be reached by both its levers.

### 3.6 Emergency lever

In case of emergency, the electronic system can be switched off quickly and the engines and gearboxes can be operated directly by the mechanical emergency levers. If you have the connector panel in front of you, the right emergency lever is for gearbox, the left emergency lever is for engine.

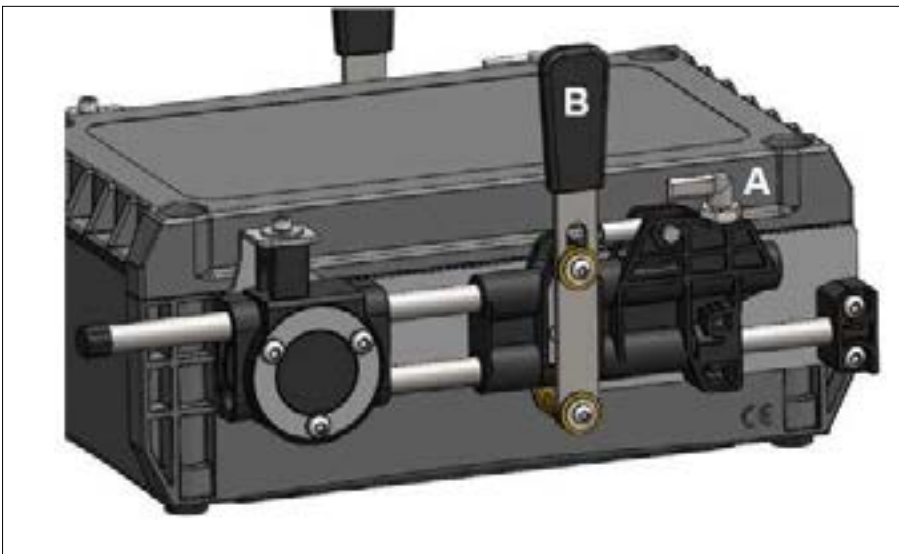

Emergency levers are fitted on the control box. During the normal functioning, the indexing plunger device "A" is positioned as shown in the picture on the left. In emergency situation, to unlock the mechanism it is enough to rotate of 180° the plunger "A" from its working position. After this operation, the mechanism (and the related push-pull cable) can be operated manually using lever (B).

In order to engage again the system you must:

1. Rotate or assure that the mechanical indexing plunger device "A" is in lock position (like in the picture)
2. Place the emergency lever "B" in the centre of stroke and move it back and forward until you hear a "click".
3. Verify that after the "click" the lever is engaged (you cannot move it freely by hand). In case the emergency lever is still free, repeat operations from point 1 to 3.

## 4 Command station

Command stations are classified as devices for the control of one or two engines, with or without trim/flap command. After serial number 18500 there can be mounted in the same installation an unlimited number of command stations, before serial number 18500 the number of command stations in the same installation is limited to 3; for detailed information look at section 7.7.

Depending on the application, it is very important to set the dip-switches present on the bottom part of the command station, as described in sections 4.4 and 7.6 of this manual.

### How to mount the Command Station

Command stations cannot be directly or indirectly mounted onto sources of vibrations. At chapter 17 of this manual you find the drilling mask drawings.

#### 4.1 Dimensions

##### 4.1.1 Command station EC3

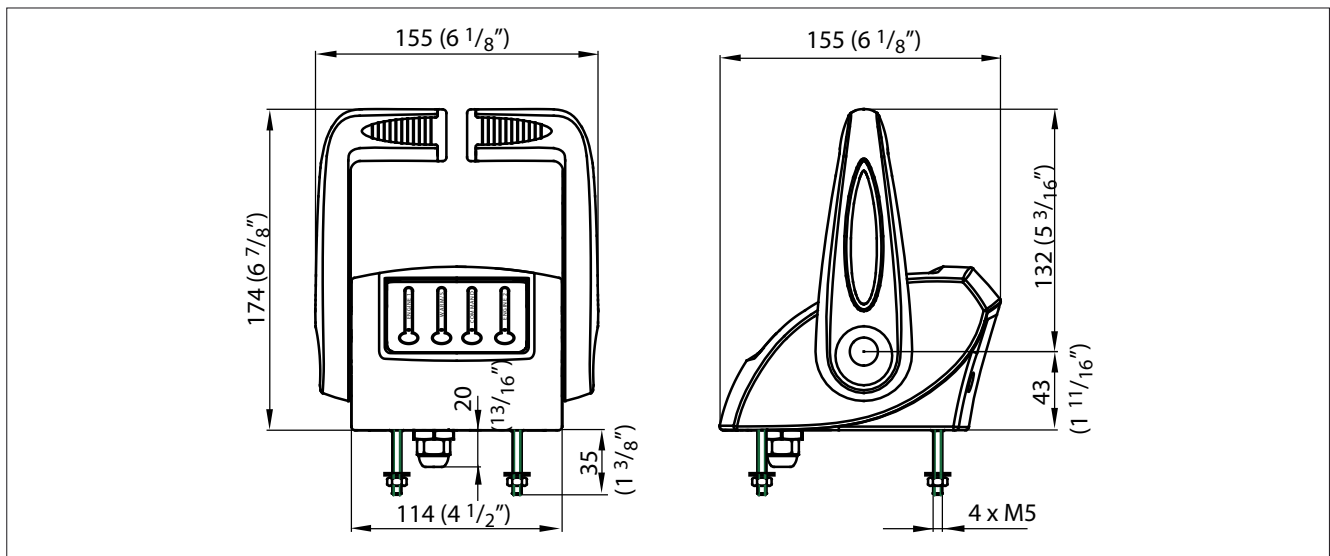

**Important:** in case the screws to fix command station to the dashboard panel are not long enough, don't open the command station to replace them but ask for an adaptation kit.

##### 4.1.2 Command station EC4

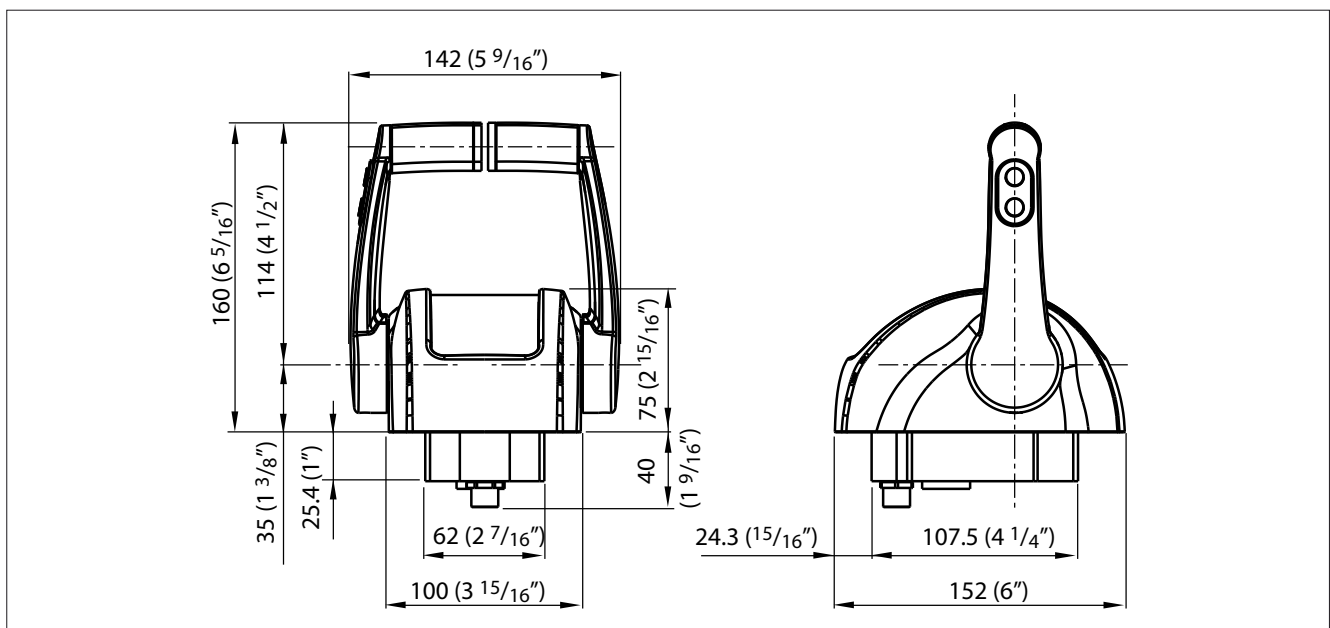

## 4.2 Friction adjustment

### 4.2.1 Command station EC3

To adjust the inner friction of the command lever, remove the PVC cap (A) and unscrew the fixing screw (B). It is possible to adjust the friction screwing and unscrewing the inner screw placed into the hole. When the regulation will be done, mount the screw and the plastic cap.

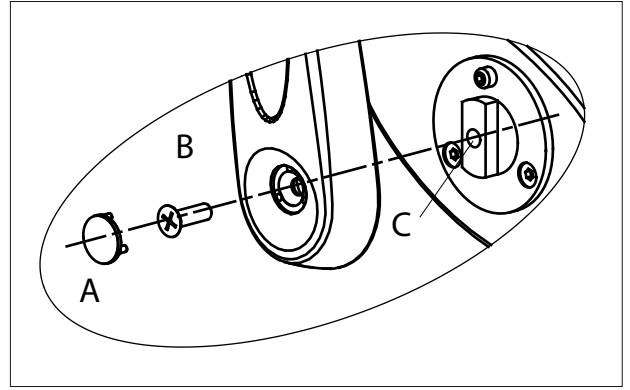

## 4.3 Programming of the command station

### 4.3.1 For command stations before serial number 18500

At power up, the command station makes a sequence of two flashes. The first flash identifies the number of engines and the second identifies the number of actuators present in the system. According to the length of each flash, the command station is differently configured.

You need to configure the command station in relation to the type of installation. It is also possible to modify the configuration of the command station by keeping pressed before powering up and continuing to keep them pressed for 6 seconds after power up, the following push buttons:

- Warm/Sync + Command, in this case you want to change the number of actuators
- Engine left + Engine right, in this case you change the number of engines on the boat

Possible configurations are according to the following table:

	1° flash (identifies the number of motors)	2° flash (identifies the number of actuators)
Installation with 1 engine and 1 actuator	Long (3 seconds)	Long (3 seconds)
Installation with 2 engines and 1 actuator	Short (less than 1 second)	Long (3 seconds)
Installation with 2 engines and 2 actuators	Short (less than 1 second)	Short (less than 1 second)

**Important:** from the factory, the command station is configured with the first flash short and the second flash long.

1. To configure the command lever for an installation with 2 actuator boxes, press the push buttons Warm/Sync and Command before powering up the command station and continue to keep them pressed for 6 seconds. The lever is now configured for installations with two engines and two actuators. At the next normal power up, the command lever will make a sequence of 2 short flashes.
2. In case you need to configure again the command lever for installation with 2 engines and 1 actuator, repeat the procedure of point 1.

### 4.3.2 For command stations after serial number 18500

At power-up, the command station emits a sequence of flashes that depends on the type of station (single or double) and on the status of the DIP-SWITCH 2. The possible behaviours of the command station are the following:

Step 1: if the station is single lever all the LEDs remain ON for 2s before moving on to the next state; if the station is double lever, all the LEDs remain ON for 0.25s before moving on to the next state

Step 2: if the DIP-SWITCH 2 is ON, there is this further sequence of flashes: the two central LEDs (Command and Warm-Up) are turned on for 0.25s and then the two side LEDs (Engine) stay ON for another 0.25s. Otherwise the station goes to the next state

After step 1 and step 2 the station will perform with the normal LEDs management, based on station and system status.

	Step 1	Step 2 (only if dip-switch 2 = ON)	
	1° flash (identifies the number of engines)	2° flash	3° flash
Installation with 1 engine	Long (2 seconds)	CMD and WARM-UP light on (0,25 seconds)	ENGINES light on (0,25 seconds)
Installation with 2 engines	Short (less than 0,25 second)	CMD and WARM-UP light on (0,25 seconds)	ENGINES light on (0,25 seconds)

Note: the number of flashes corresponding to the number of actuators present in the system (as depicted in section 4.3.1.) is no longer executed.

### 4.3.3 EC4 two-engine stations: how to assign the Synchro function to the operating lever (after serial number 18500)

By default the Synchro function is assigned to the left lever. It is possible to change or assign the Synchro function either to the left or to the right lever, following the instructions here below:

1. activate the Synchro as usual
2. bring both levers in neutral
3. press the two push-buttons on the side of the lever that you want to use for the Synchro:  
    "Engine" left and "Synchro / WarmUp" for the left lever  
    "Command" and "Engine" right for the right lever
4. keep the push buttons pressed for at least 10s
5. if the operation is successful, the LEDs pair corresponding to the push buttons pressed will flash

The programming is then stored in the device memory. The operation must be repeated for all the control stations of the system.

## 4.4 Command station label

There is a label under the base of the command station.

This label shows the code and the serial number of the command station. The dip-switches configure the control station on the base of its position in the CANBus network. The dip switch selector is represented with a small black square.

Command station 1, Command station 2, Command station 2 and Command station FSM are different addresses on the CANBUS network.

If there are multiple stations in the same system, each one must have a different address. "Command station FSM" and "Command station 1" cannot coexist in the same installation. "Command station FSM" is an alternative to "Command station 1" and vice versa.

Chapter 7 lists the most common types of systems, which can only be configured with a correct dip-switch setting. 4.5. Trolling option

DIP switch configuration				
	1	2	3	4
Command station 1	<input checked="" type="checkbox"/>	<input type="checkbox"/>	<input type="checkbox"/>	<input type="checkbox"/>
Command station FSM	<input type="checkbox"/>	<input type="checkbox"/>	<input checked="" type="checkbox"/>	<input checked="" type="checkbox"/>
Command station 2	<input type="checkbox"/>	<input checked="" type="checkbox"/>	<input type="checkbox"/>	<input checked="" type="checkbox"/>
Command station 3	<input type="checkbox"/>	<input type="checkbox"/>	<input checked="" type="checkbox"/>	<input checked="" type="checkbox"/>
Code	Line termination		Trolling	Address
S/N	<input checked="" type="checkbox"/> ON <input type="checkbox"/> OFF			

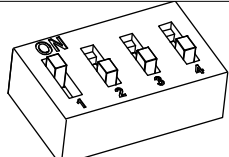
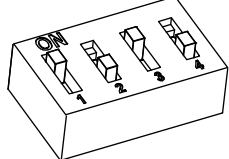
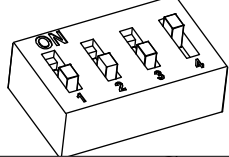
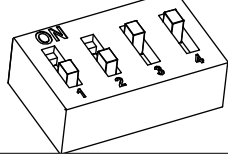
Dip-switch configuration details	
Command station 1	
Command station FSM (Fast Start-up Mode)	
Command station 2	
Command station 3	

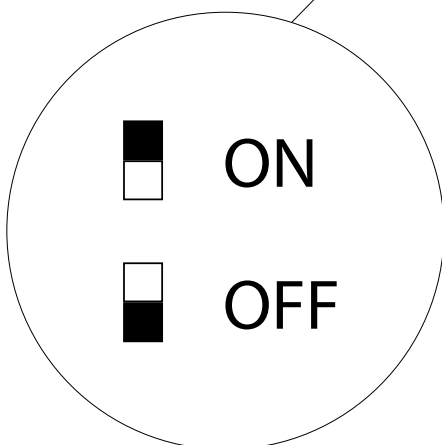

## 4.5 Trolling option

To activate the Trolling function, dip-switch 2 must be set to ON. For specific information refer to the document "Trolling\_Flap option for lever EC3 & EC4".

## 4.6 Trim/Flap option

Trim/flap command can be activated directly from the command station with the buttons '+' and '-'. The commands are sent to the actuator from the command station. The relay card fitted on the actuator activates the hydraulic pump of the trim/flap.

For installations with two engines, in case of "Synchro" mode operation, the buttons on the right-hand side operate the both the trims (or the flaps) simultaneously.

### Command station EC3

Version for one engine



Version for two engines



### Command station EC4

Version for one engine

Trim or flap can be activated directly from the command station with "+" and "-" push-buttons. These push-buttons are placed on the lateral side of the left lever.

Version for two engines

Trims/flaps are tuned with "+" and "-" pushbuttons placed on the keypad (a couple for each engine).

It is also possible to command the trims/flaps in Synchro with the "+" and "-" push buttons placed on the left lever.

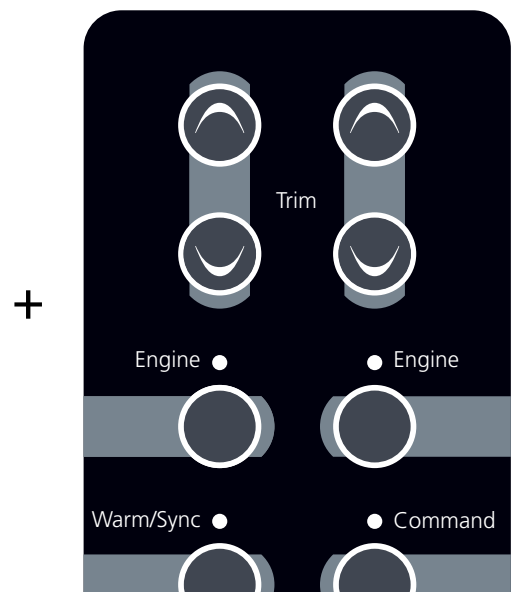



## 4.7 Advices about the mounting and preservation of the Command Station

In case of outdoor installation, being the command station not designed to be submerged by water, to be exposed directly to water jets, or to be cleaned with pressurized water/steam, please notice:

- Command station cannot be installed in areas where water can be retained or where there is the potential risk of creating water puddles.
- Command station cannot be submerged or directly exposed to waves or water jets.
- Command stations are made of materials resistant to marine environment; in any case, it is essential to remove periodically salt deposits on the external surfaces to avoid corrosion and consequentially system inefficiency.
- It is not allowed to clean the command station with hydro-cleaner or any watering directly to the command station.
- Do not use aggressive chemicals for cleaning the command station.
- When not in use, put on the command station the protection cover. In case the cover is not included into the supply, it is possible to order it separately.

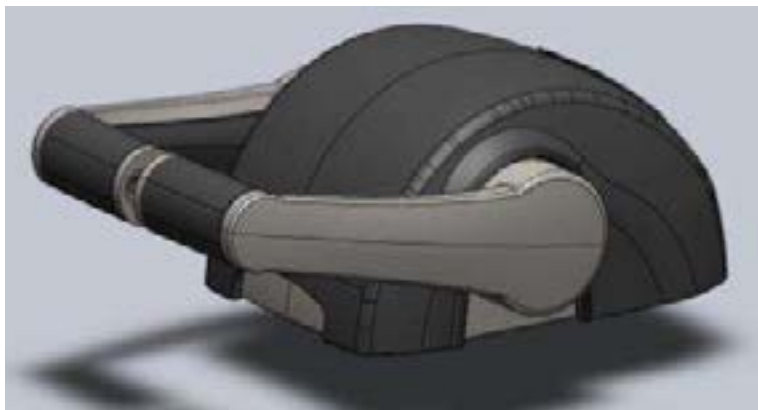

## 4.8 Command station codes

Command stations	
Description	Code
Command station 1 motor EC3	EC3H1
Command station 1 motor EC3 with TRIM option	EC3HT1
Command station 2 motors EC3	EC3H2
Command station 2 motors EC3 with TRIM option	EC3HT2
Command station 1 motor EC4	EC4H1
Command station 1 motor EC4 with TRIM option	EC4HT1
Command station 2 motors EC4	EC4H2
Command station 2 motors EC4 with TRIM option	EC4HT2

## 5 Actuator

With reference to the type of engine and gearboxes, with or without trim/flap, actuators are classified as follow:

- mechanical
- electronic
- mechanical & electronic

It follows the drawings of the different types of actuators. In the last page of this manual you find the footprint of the actuator in scale 1:2.

### 5.1 Drawing of actuators with mechanical interface

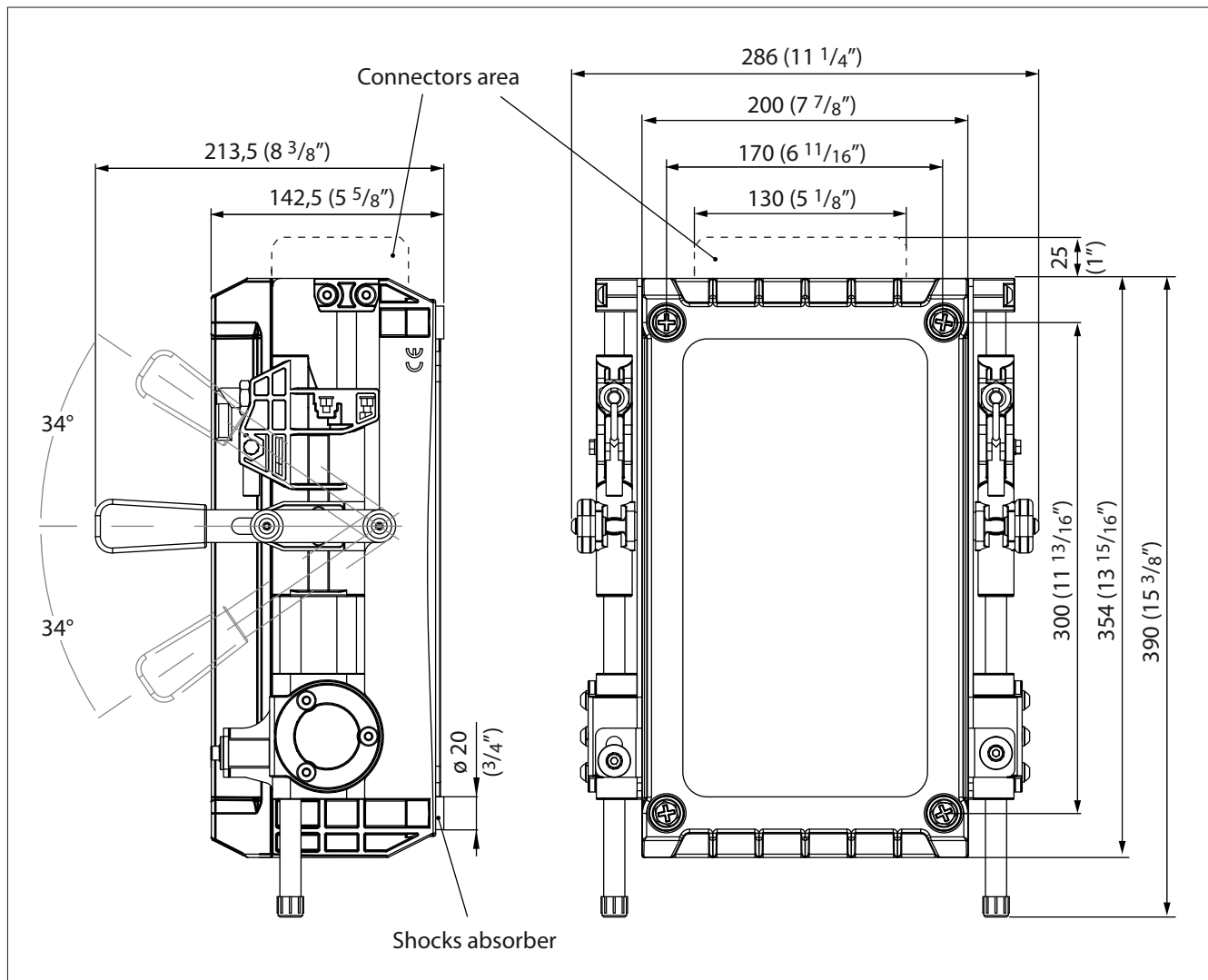

## 5.2 Drawing of full electronic actuator

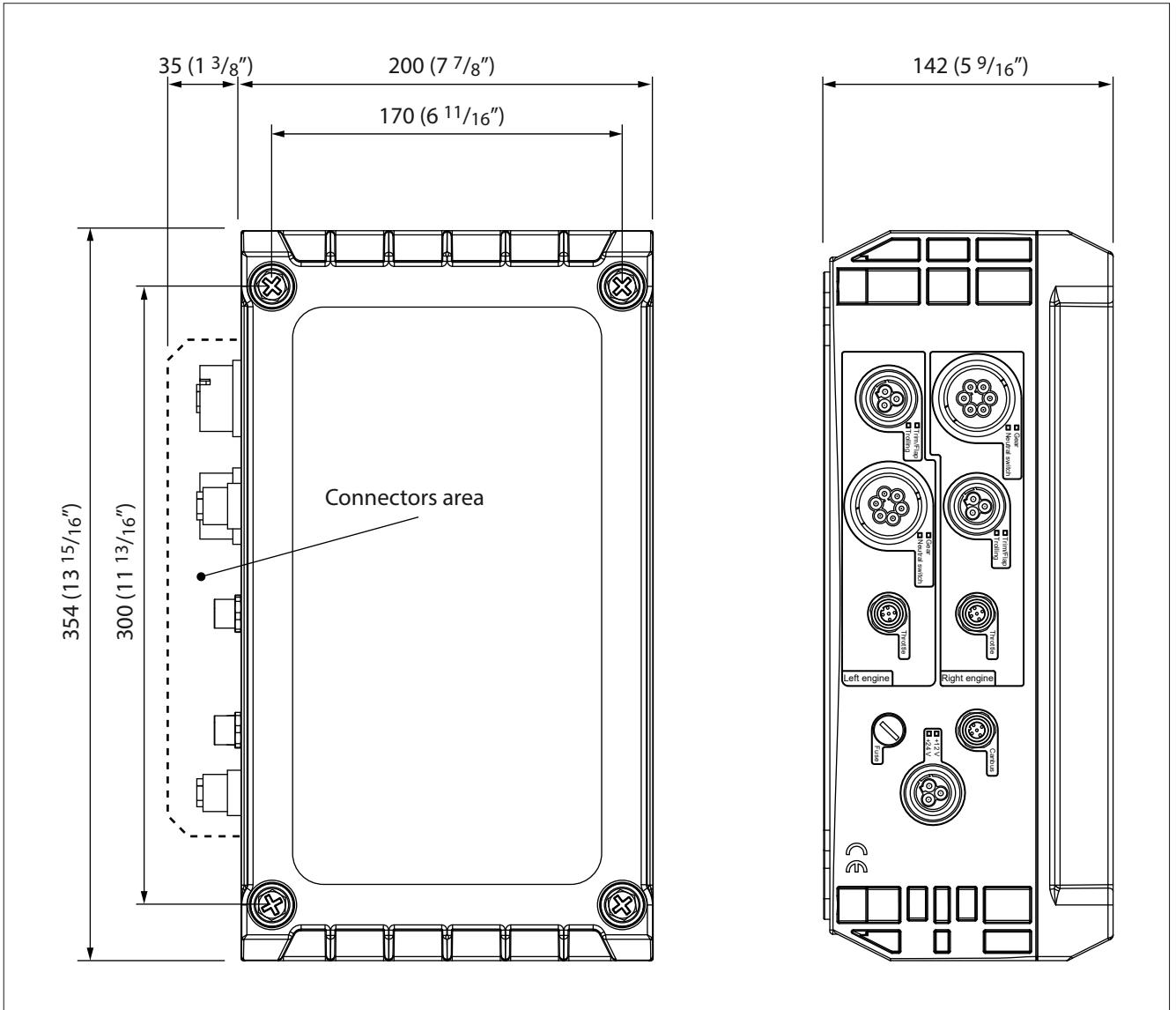

## 5.3 How to mount the Actuator

The actuator must be mounted in the engine room in a safety place and as near as possible to the propulsion engine. The actuator cannot be exposed directly to the source of vibrations, e.g. it cannot be mounted directly on the engine, on the gearbox or on the engine base.

Mount the actuator leaving a space of at least 25 cm on each side

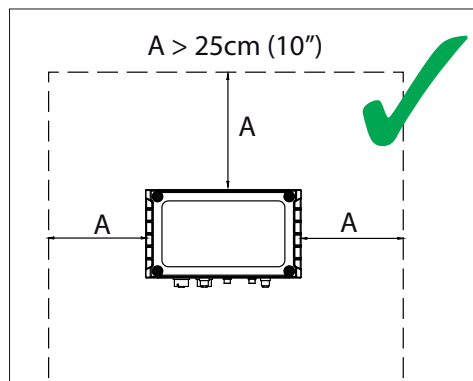
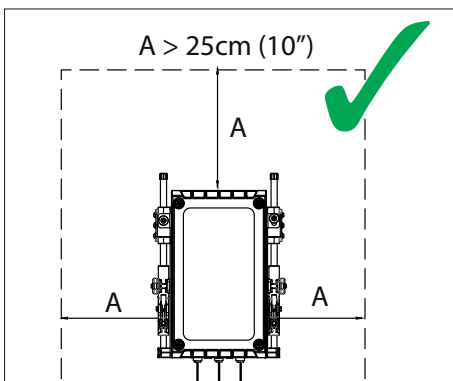

Do not install the actuator with the connectors upwards

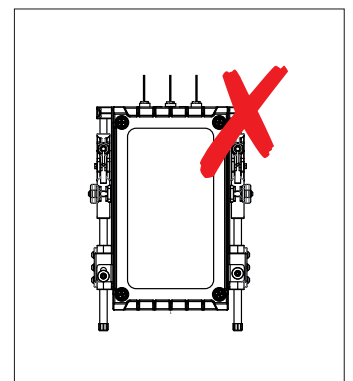

## 5.4 Electronic Actuator Boards

### 5.4.1 Actuator board ver. 3.1

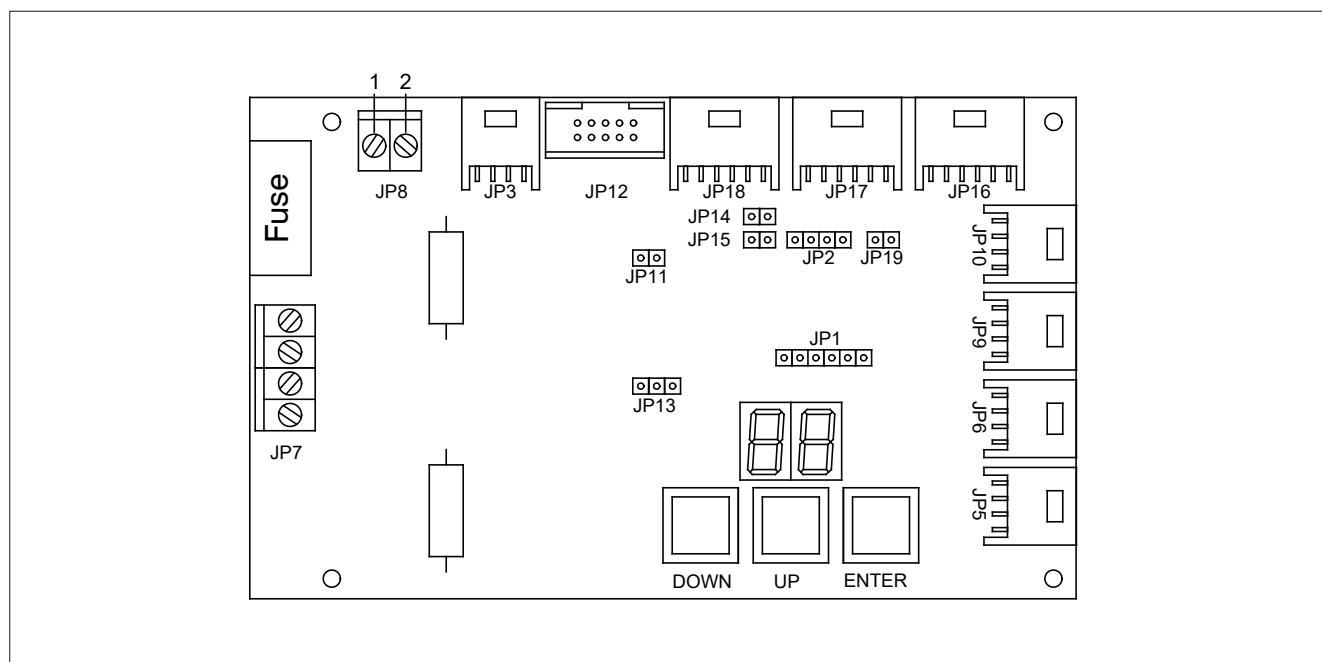

Position on board	Pin	Description	Output cable	
JP8 Supply	1	Vdc	Wall connector	
	2	GND		
JP9 Engine right	2	MOD2 (Rev.3)	4 poles	
	3			V_out CH1
	1			V_out CH2
	4			GND CH2
JP10 Engine left	2	MOD2 (Rev.3)	4 poles	
	3			V_out CH3
	1			V_out CH4
	4			GND CH4
			GND CH3	

Connectors JP9 and JP10 are dedicated to the electronic control engine device (ECU).

### 5.4.2 Relays PCB version RB 1.0 for TRIM-FLAP and neutral relays

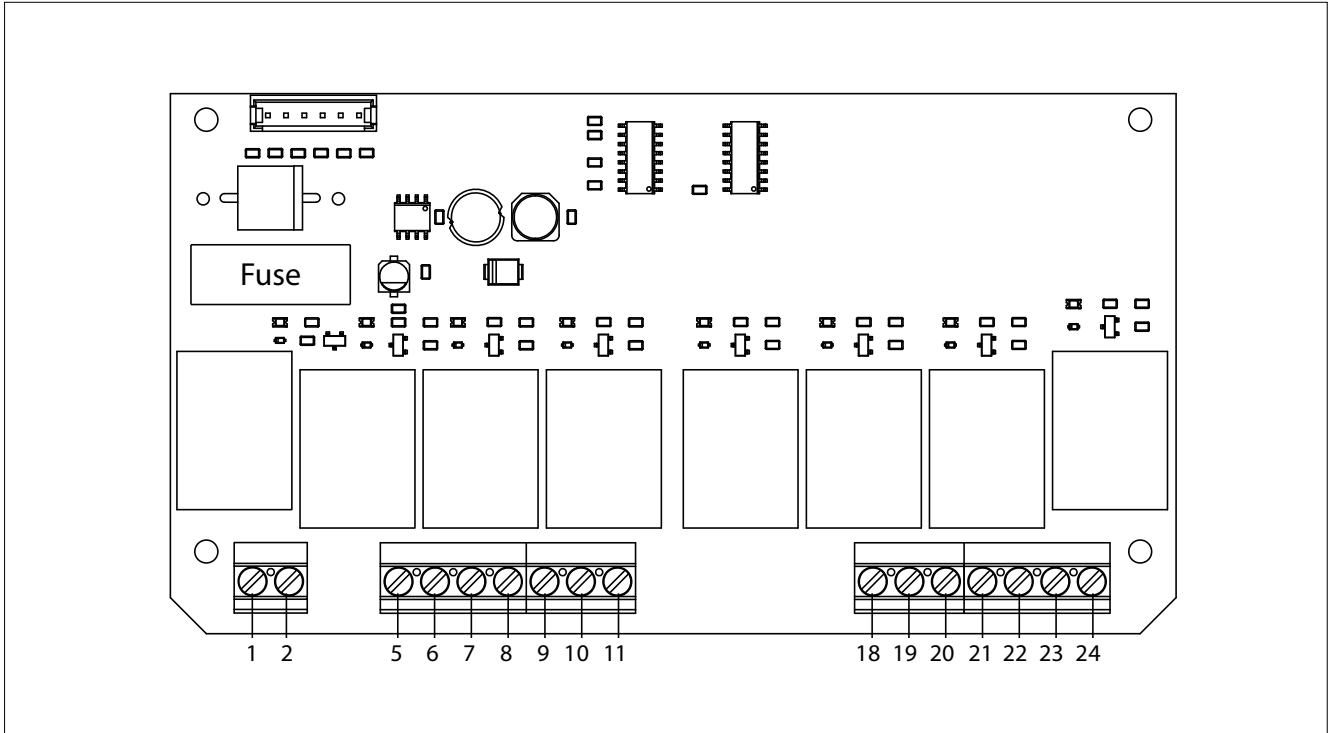

Pin	Description	
1	Vdc	
2	GND	
3	Vdc	
4	(Not used)	
5	Left engine	Trim common contact
6		Trim +
7		Trim -
8		Trailer
9		Common neutral relays contact
10		NO contact neutral relay
11		NC contact neutral relay
12	(Not used)	
13	(Not used)	
14	(Not used)	
15	(Not used)	
16	(Not used)	
17	(Not used)	
18	Right engine	Common neutral relay contact
19		NO contact neutral relay
20		NC contact neutral relay
21		Common trim contact
22		Trim +
23		Trim -
24		Trailer

### 5.4.3 Relays PCB version 2.0 for electronic gearboxes

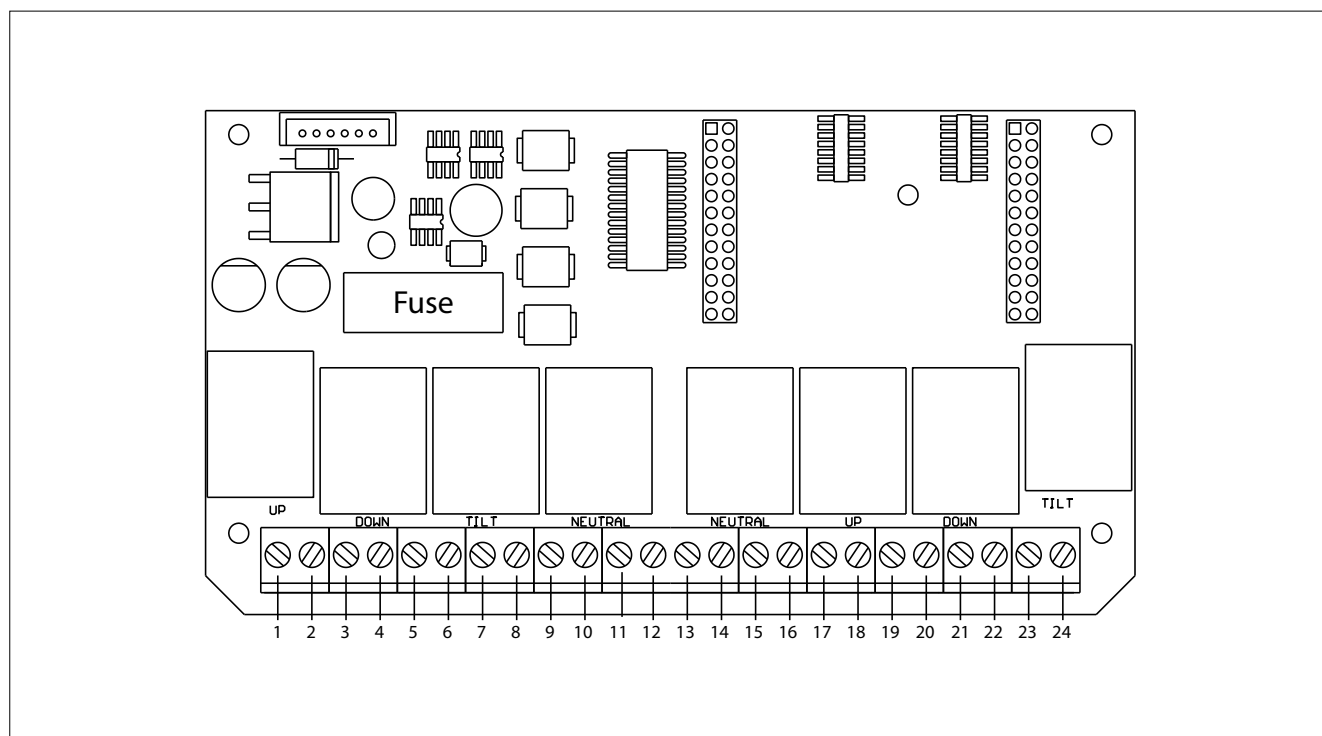

Pin	Description	
1	Vdc	
2	GND	
3	Vdc	
4	GND	
5	Left engine	Trim common contact
6		Trim +
7		Trim -
8		Trailer
9		Common neutral relays contact
10		NC contact neutral relay
11		Forward gear
12		GND
13		Reverse gear
14		GND
15	Right engine	Forward gear
16		GND
17		Reverse
18		GND
19		Common neutral relay contact
20		NC contact neutral relay
21		Common trim contact
22		Trim +
23		Trim -
24		Trailer

## 5.5 Actuator labels

Inside the actuator there are two labels indicating code and serial number. Please write them down in case you call for assistance.

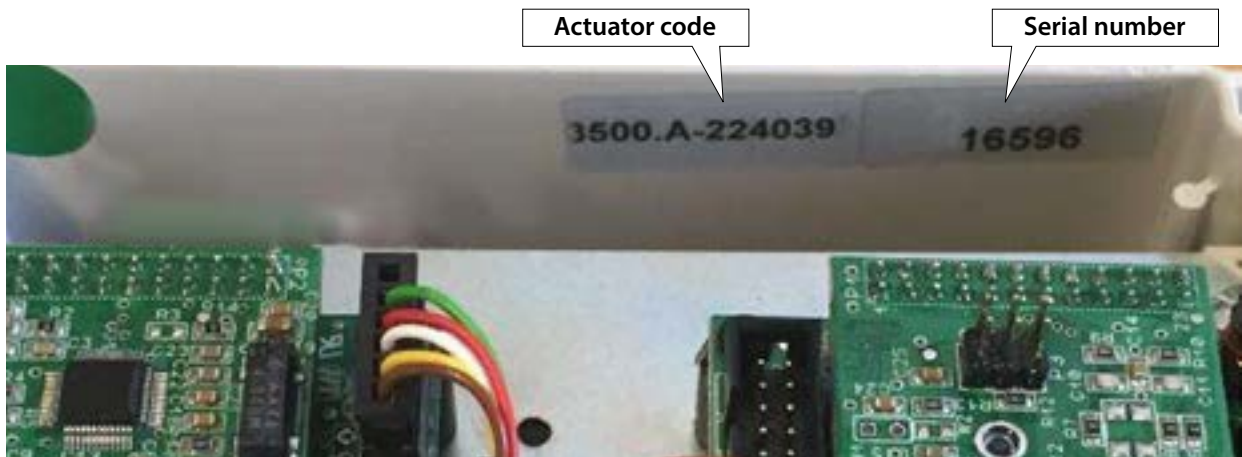

### Actuator Codes

1 mechanical engine and 1 gearbox mechanical (no trim)	EC3UMM1
1 mechanical engine and 1 gearbox mechanical (with trim)	EC3UMMT1
1 electronic engine (V) and 1 gearbox mechanical (no trim)	EC312EM1
2 electronic engines (V) and 2 gearboxes mechanical (no trim)	EC312EM2
1 electronic engine (V) and 1 gearbox mechanical (with trim)	EC312EMT1
2 electronic engines (V) and 2 gearboxes mechanical (with trim)	EC312EMT2
1 mechanical engine and 1 gearbox solenoid driven (no trim)	EC4UME1
1 mechanical engine and 1 gearbox solenoid driven (with trim)	EC4UMET1
2 mechanical engines and 2 gearbox solenoid driven (with trim)	EC4UMET2
1 mechanical engine + electric gear + trolling	EC4UMETR1
2 electrical engines + electrical gear + trolling	EC4UEETI

\*) identifies the power supply voltage; (\*) = 2 identifies actuators with only 24 Vdc; (\*) = 3 identifies actuators which can work with both 12 and 24 Vdc.

All actuators with electronic gearbox interface have the neutral relay option already implemented.

## 6 Accessories and Options

Cables reported here below are used in standard installations. For specific engines there are anyhow available cables with their proper connectors; in case you need cables for specific engines, please contact the supplier.

**For a correct mounting plug in the connector at 90° with respect to wall side of the actuator box. Rotate then the ring until the cable enters into the counterpart M12.**

If the cable has been inserted correctly, it must be possible to screw completely by hand the cable without too much efforts. The best electrical connection and the max water protection of this connector is reached when screwed with **around six turns**.

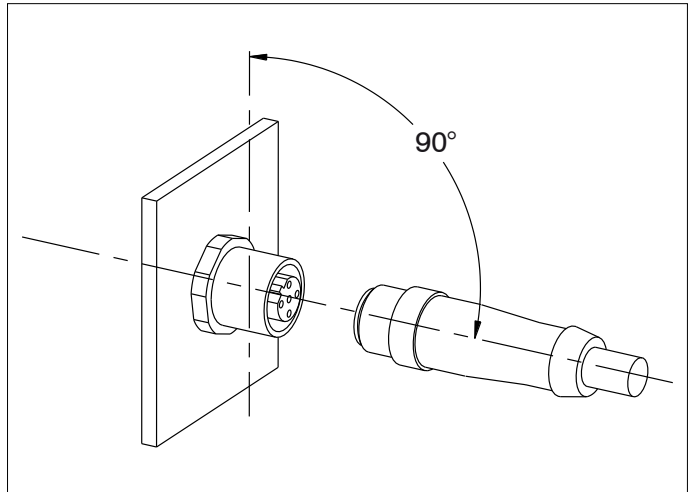

### Connector for throttle cables

Engine cables must be installed as far as possible from heat generating sources. If the cable is running for some of its length nearby the engine, protect this part of the cable with a cover suitable to reflect the heat generated by the engine.

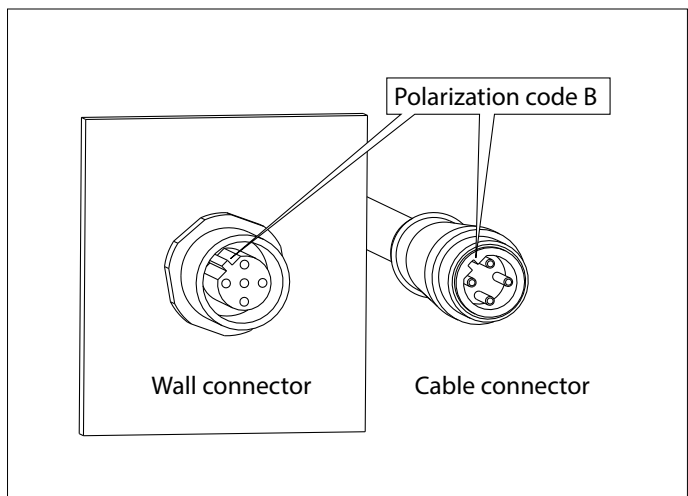

### Connector for CANbus data transmission cable

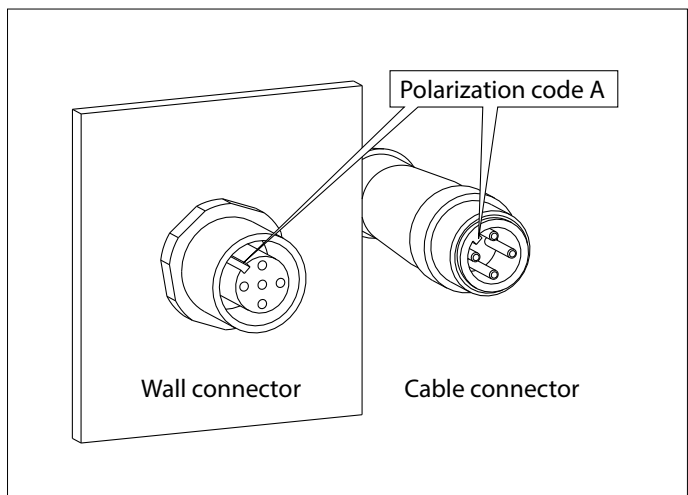



## 6.1 CANBus cable

### 6.1.1 CANBus data transmission cable

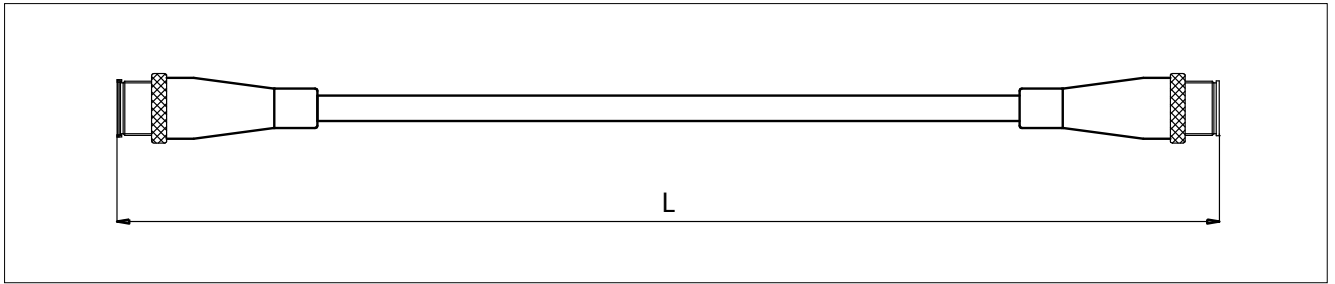

Length	Code	Length	Code
L=3 m	DTCAN3M	L=10 m	DTCAN10M
L=5 m	DTCAN5M	L=15 m	DTCAN15M
L=7,5 m	DTCAN7,5M		

### 6.1.2 CANBus extension cable

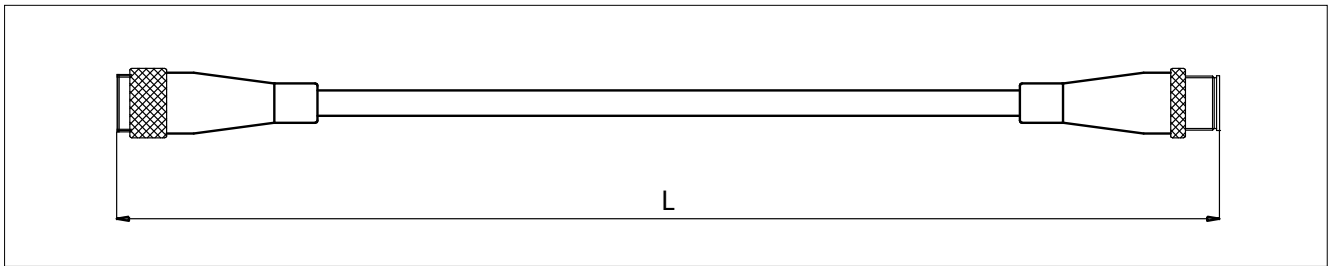

Length	Code
L=30 m	DTCAN30M

## 6.2 Cable for electronic engine

### 6.2.1 Cable for 1 electronic engine with 1 channel: 0 - 5 V

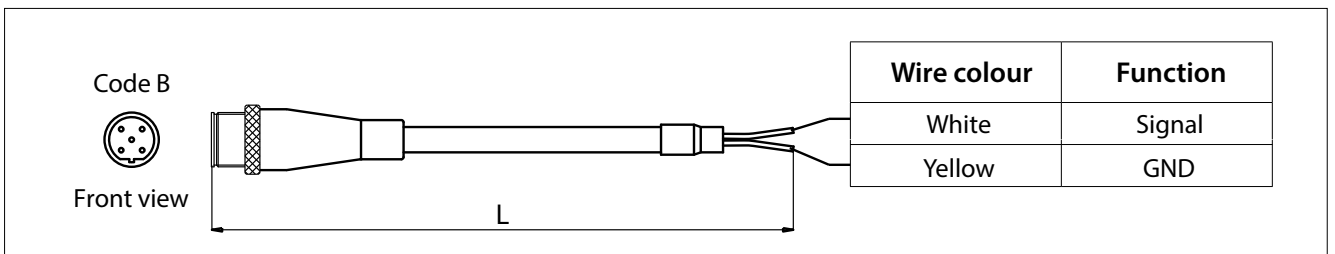

Length	Code
L=3 m	EC3E3U

**Important:** this cable is without connector on engine side

### 6.3 Cable actuator – gearbox solenoid driven

For the connection towards the gearbox solenoid driven, please refer to sections 8.2.1 and 8.2.3. of this manual.

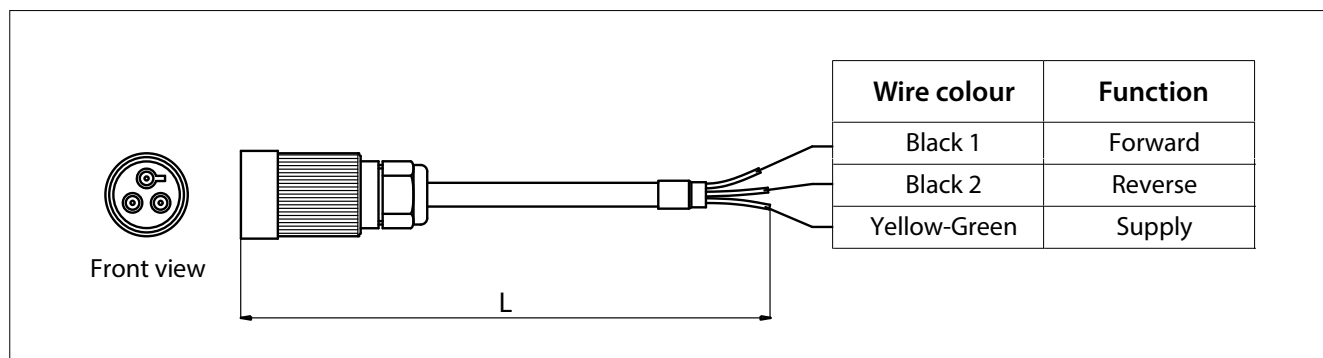

Length	Code
L=3 m	EC3T2

**Important:** this cable is without connector on engine side

#### 6.3.1 Cable actuator - gearbox solenoid driven + neutral relay signal

For the connection towards the gearbox solenoid driven, please refer to sections 8.2.2. and 8.2.4. of this manual.

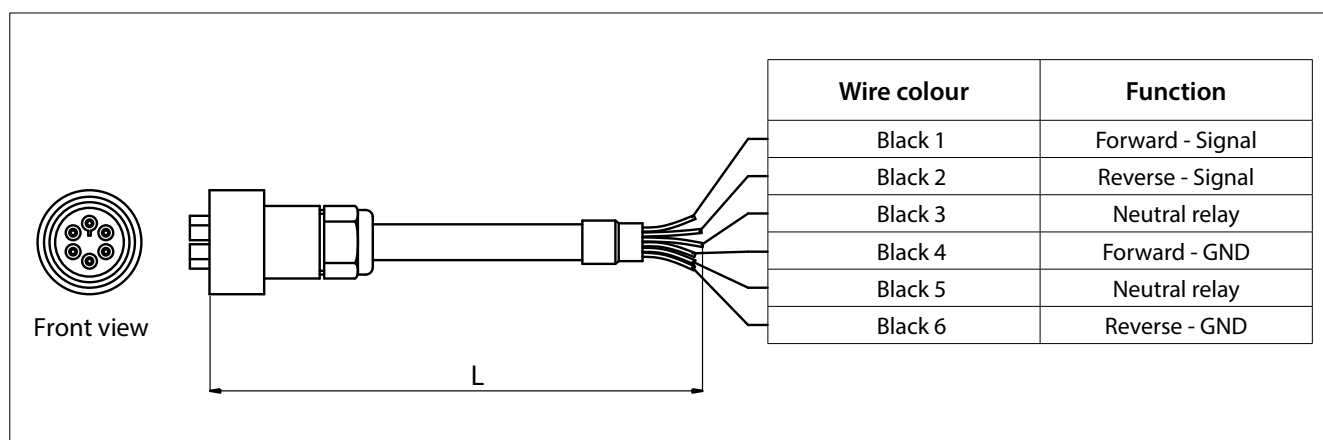

Length	Code
L=3 m	ECG3/6

**Important:** this cable is without connector on gearbox side

## 6.4 Cable actuator – trim/flap

For the connection to trim/flap, please refer to sections 8.2.7. and 8.2.8. of this manual.

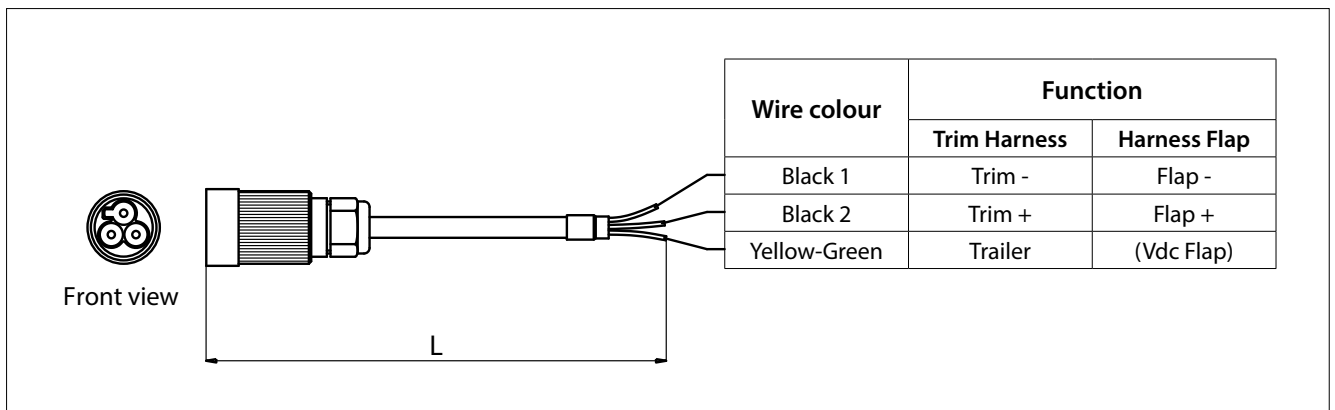

Length	Code
L=3 m	EC3T3M

## 6.5 Cable actuator – Mercruiser® trim pump

The cable for the trim pump of Mercruiser sterndrive has a length of 3 meters; in the cabling are included the fast-on connections to the micro-switch for the end of stroke of the tilt.

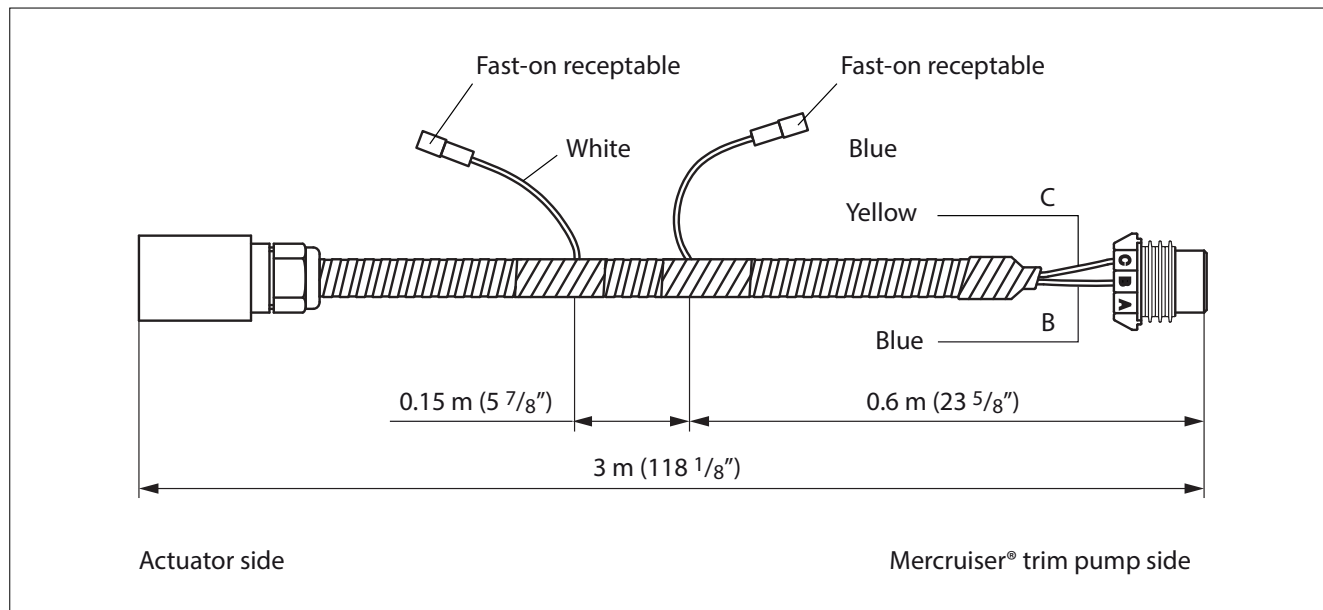

Length	Code
L=3 m	EC3T3MM

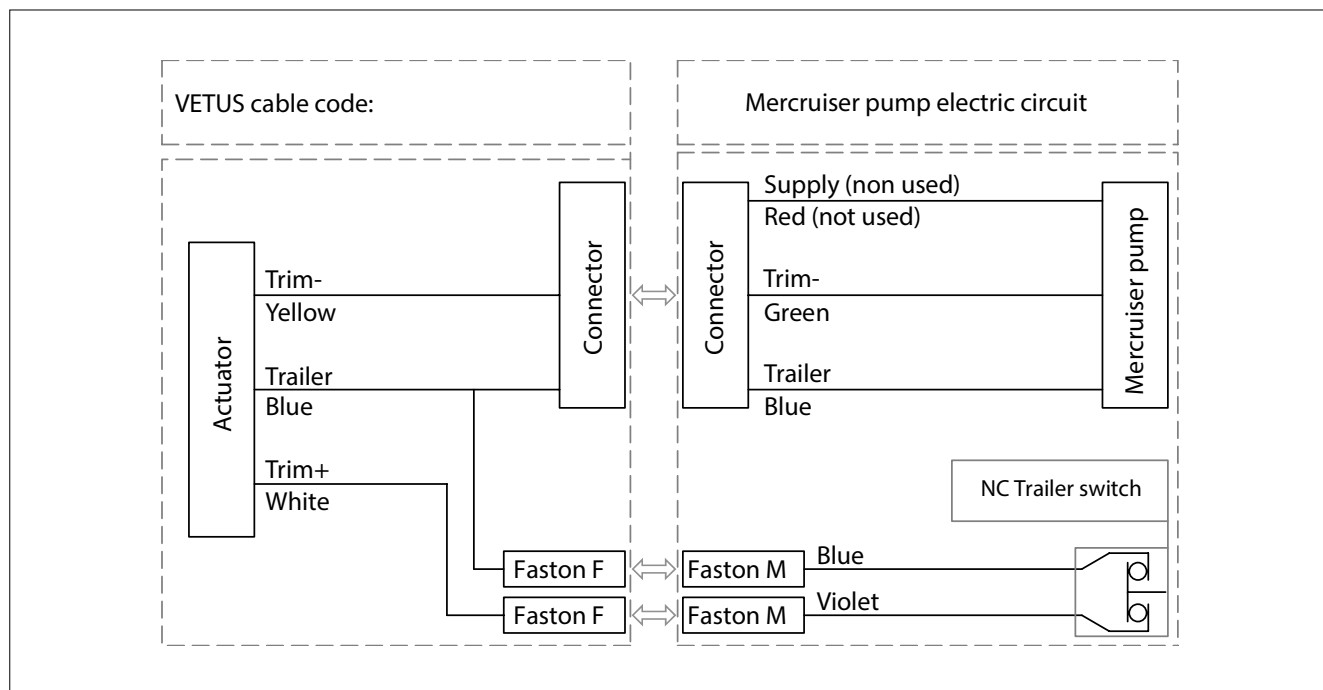

## 6.6 T-Splitter

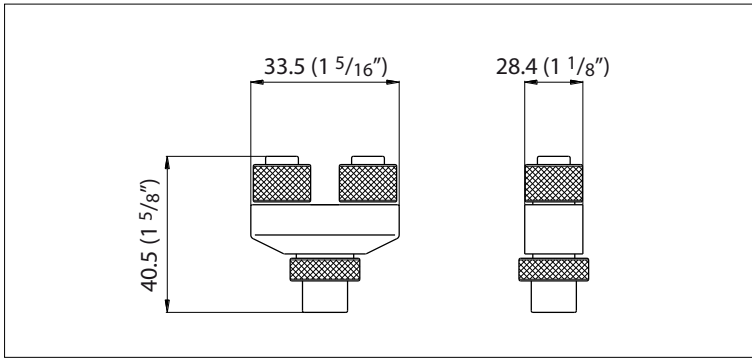

Code: CANT

## 6.7 Power supply connector

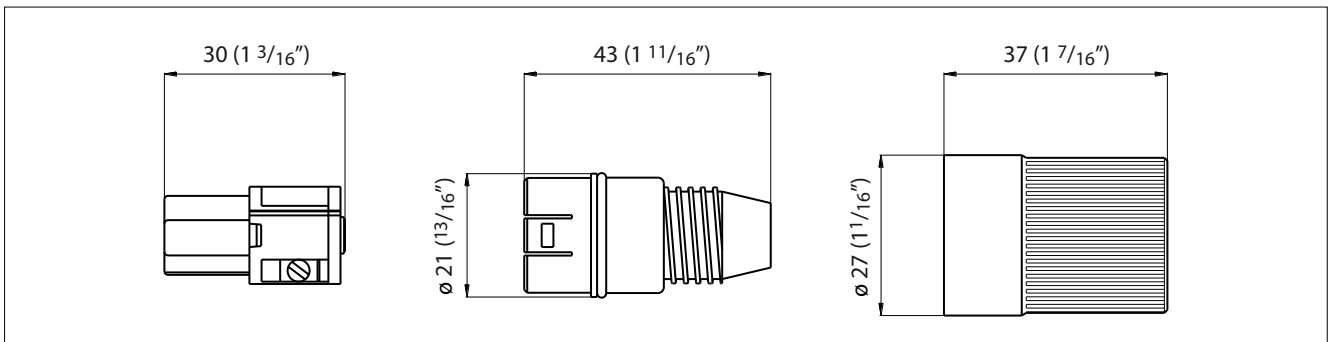

Code: EC3SUP

**Important:** cabling instruction of power supply connector are at section 8.1.1. of this manual.

# 7 Configuration of the CANBus network

## System types, installation schemes and addressing for command stations and actuators

How to configure the installation depends from the quantity, type of engines and gearboxes and number of command stations. Actuators and command stations, which communicate together through the CANBus network, must be configured in relation to how they are connected to the CANBus network. In the following installation schemes you find:

- Components necessary to build an installation
- Configuration of actuators and command stations in relation of their position on the CANBus network

The following installation schemes cover the most common application cases.

### 7.1 Installation with 2 mechanical actuators – solution A

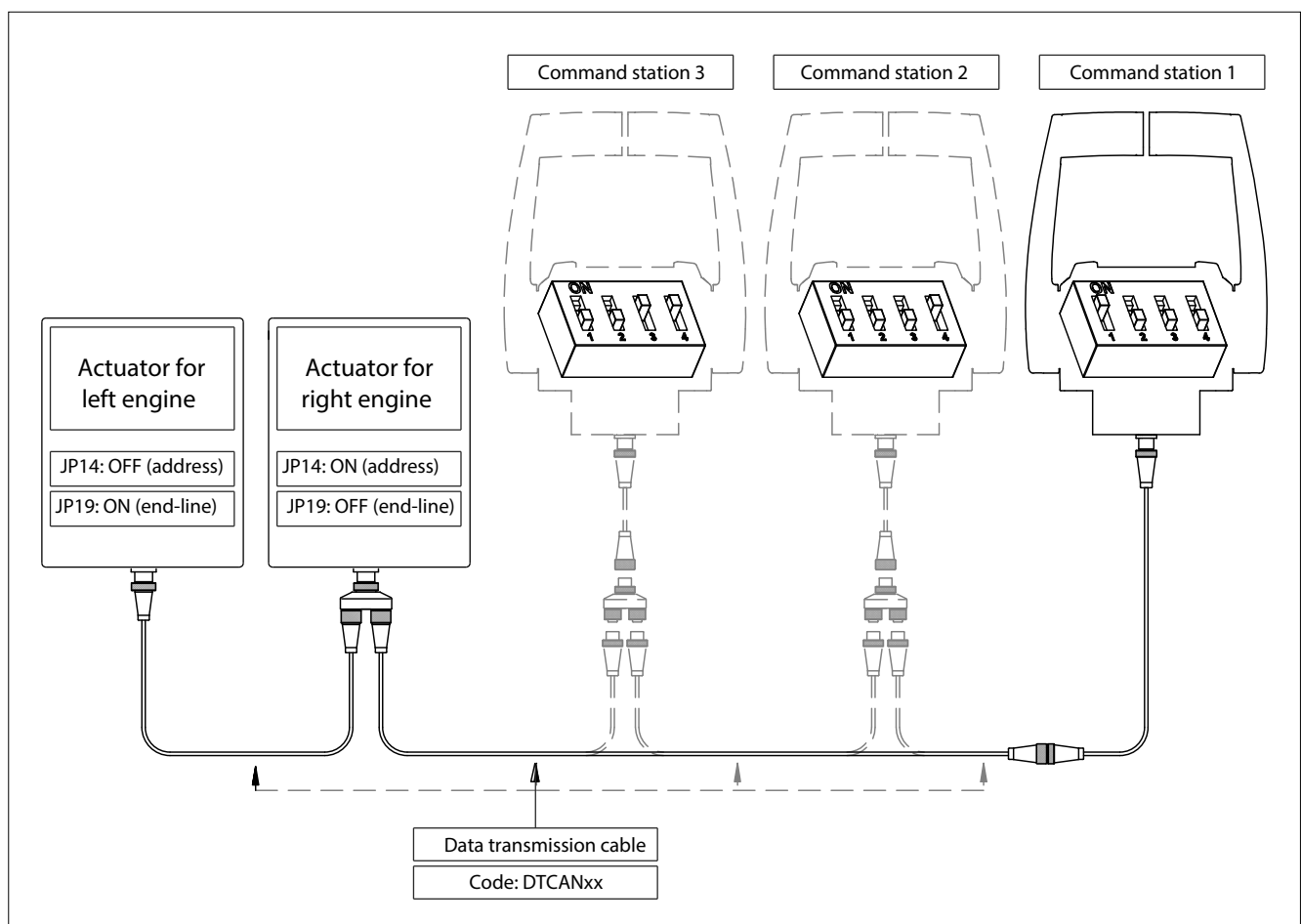

This installation scheme is valid for systems with:

- Up to 3 command stations and 2 engines with mechanical throttle, mechanical gearbox, with/without trim;

## 7.2 Installation with 2 mechanical actuators – solution B

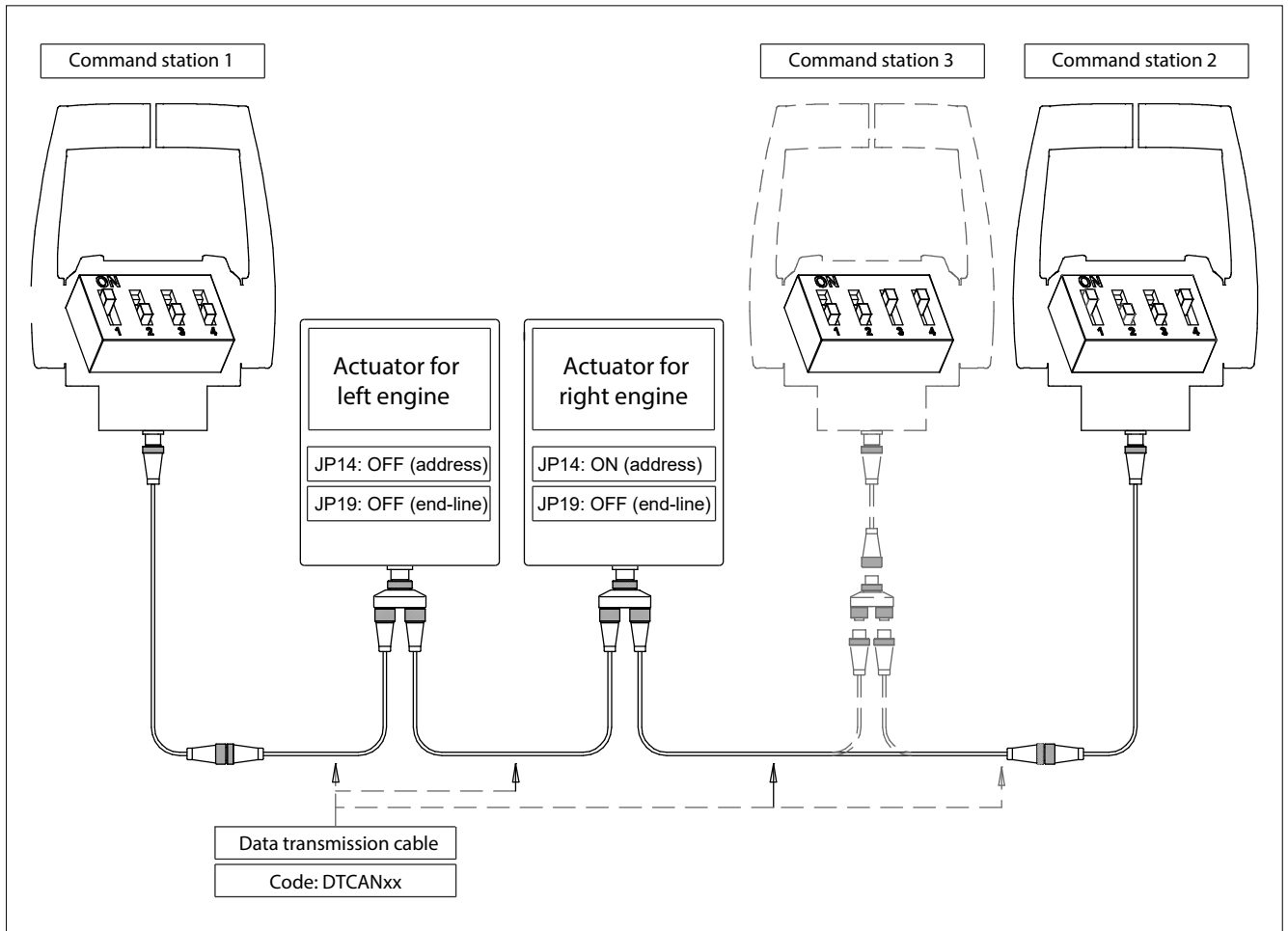

This installation scheme is valid for systems with:

- Up to 3 command stations and 2 engines with mechanical throttle, mechanical gearbox, with/without trim;

### 7.3 Installation with 2 mechanical actuators – solution C

Actuators are placed at the ends of the CANBus network

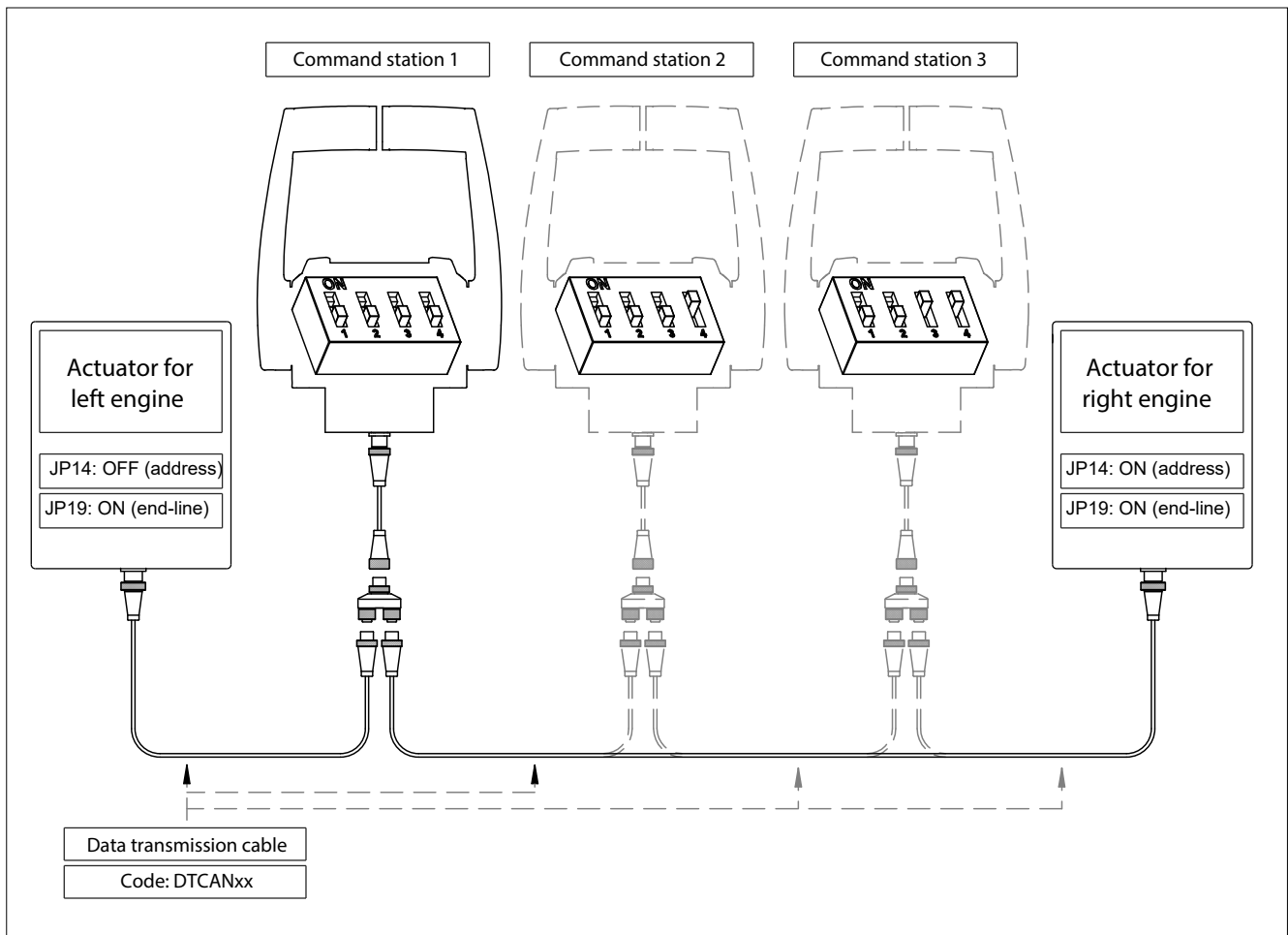

This installation scheme, typical for catamaran applications, is valid for systems with:

- Up to 3 command stations and 2 engines with mechanical throttle, mechanical gearbox, with/without trim;



## 7.4 Installation with 1 actuator – solution D

The actuator is placed at one end of the CANBus network.

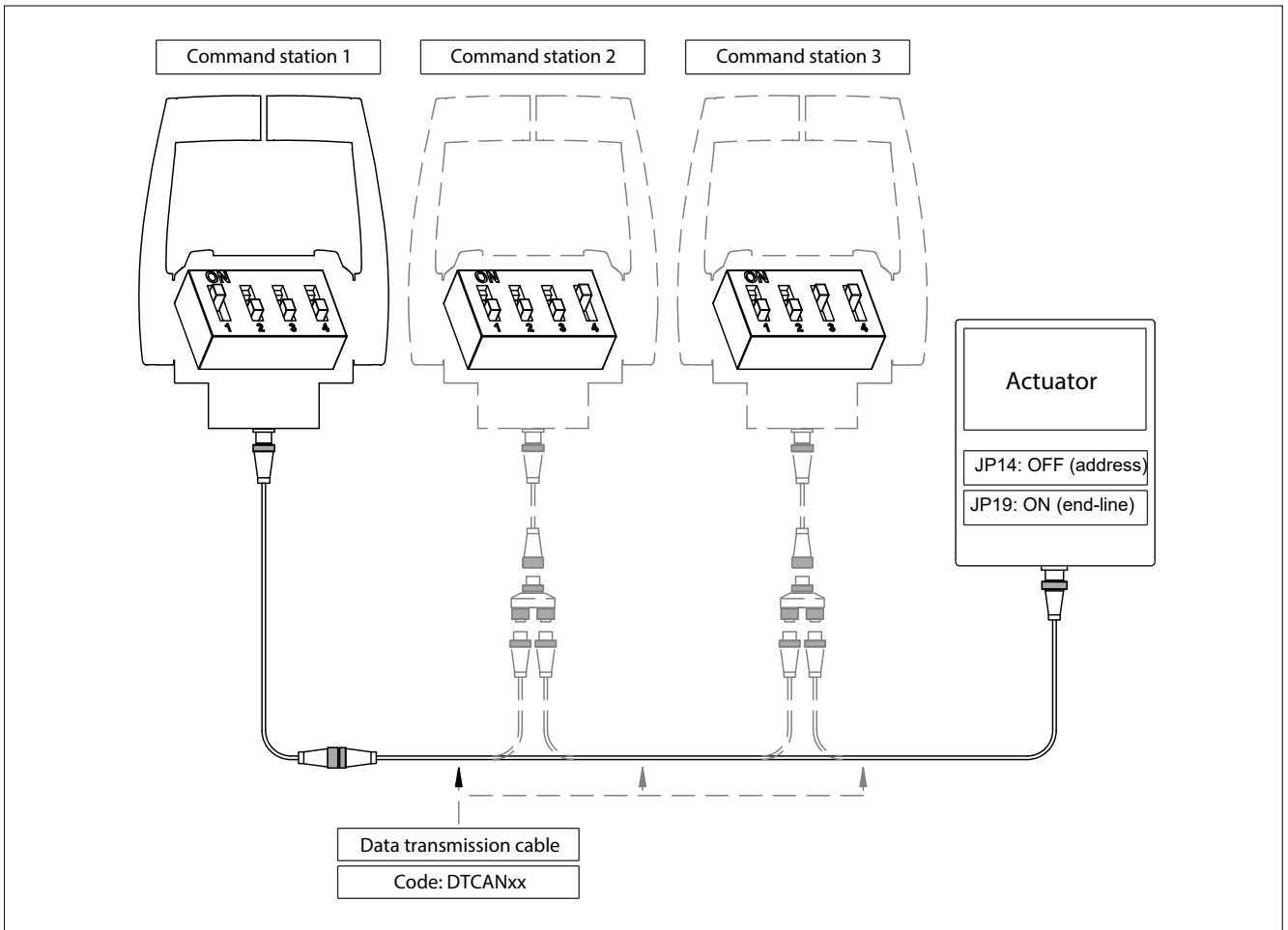

This installation scheme is valid for systems with:

- up to 3 command stations and 1 engine with mechanical throttle, mechanical gearbox, with/without trim (or flap);
- up to 3 command stations and 1 or 2 engines with electronic throttle (voltage or CANBus), mechanical gearbox, with/without trim (or flap);
- up to 3 command stations and 1 or 2 engines with electronic throttle (voltage or CANBus), solenoid driven gearbox, with/without trim (or flap);

## 7.5 Installation with 1 actuator – solution E

The actuator is placed in the middle of the CANBus line.

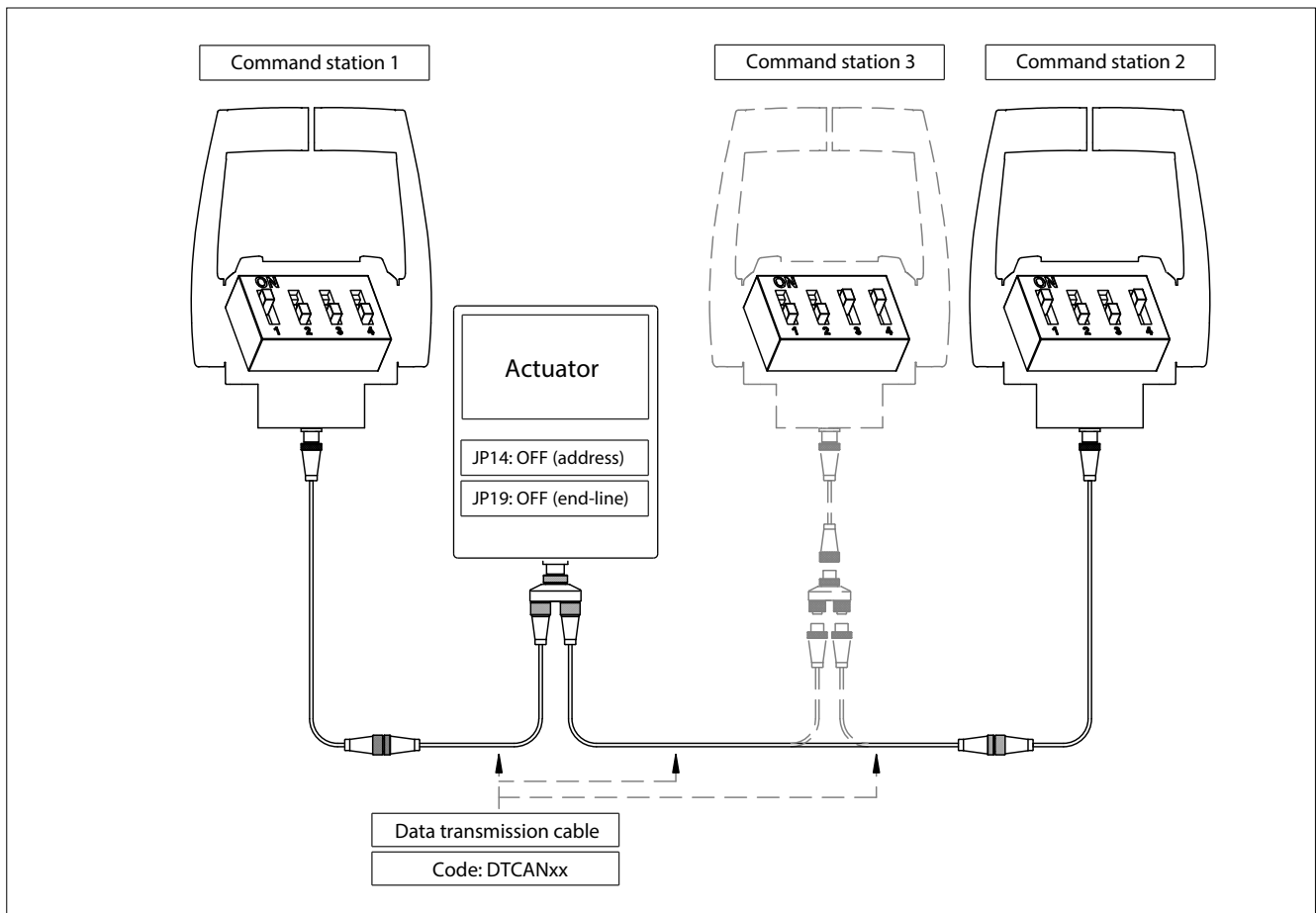

This installation scheme is valid for systems with:

- up to 3 command stations and 1 engine with mechanical throttle, mechanical gearbox, with/without trim (or flap);
- up to 3 command stations and 1 or 2 engines with electronic throttle (voltage or CANBus), mechanical gearbox, with/without trim (or flap);
- up to 3 command stations and 1 or 2 engines with electronic throttle (voltage or CANBus), solenoid driven gearbox, with/without trim (or flap);

## 7.6 Configuration: end of line termination resistor and address setting of command stations and actuators

According to the number and to the position on the CANBus communication net, command stations and actuators must be configured to guarantee the correct functioning of the system. End of line termination resistors must be enabled on the devices placed at the end of the CANBus network. Configuration of the command station

### 7.6.1 Configuration of the command station

It is mandatory to setup the command station in relation to its position on the CANBus net. Each command station must have a different address number and if the command station is connected at the end of the CANBus net, the end line dip-switch must be enable (ON).

Under the base of the command station there is a plastic cap. Unscrewing it, you have access to the dip-switches.  
Operation:

- unscrew the plastic cap;
- set the dip-switch according to one of the configurations described in chapter 7
- screw again the cap.



DIP switch configuration				
	1	2	3	4
Command station 1	<input type="checkbox"/>	<input type="checkbox"/>	<input type="checkbox"/>	<input type="checkbox"/>
Command station FSM	<input type="checkbox"/>	<input type="checkbox"/>	<input type="checkbox"/>	<input type="checkbox"/>
Command station 2	<input type="checkbox"/>	<input type="checkbox"/>	<input type="checkbox"/>	<input type="checkbox"/>
Command station 3	<input type="checkbox"/>	<input type="checkbox"/>	<input type="checkbox"/>	<input type="checkbox"/>
Code	Line termination	Trolling	Address	
S/N				
	<input type="checkbox"/> ON			
	<input type="checkbox"/> OFF			

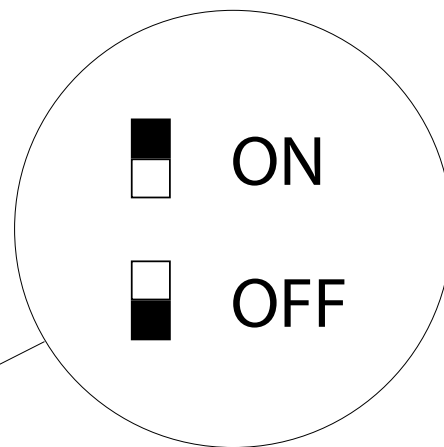

- Dip-switch 1:** OFF end-line resistance disabled  
ON end-line resistance enabled
- Dip-switch 2:** trolling option
- Dip-switch 3 and 4:** identify the command station

The dip-switches configure the command station according to its position in the CANBus network. The selector of the dip switch is represented in the nearby label with the black square.

	Dip- switch 3	Dip- switch 4
Command station 1	OFF	OFF
Command station Fast Start-up Mode (this is alternative to command station 1)	ON	OFF
Command station 2	OFF	ON
Command station 3	ON	ON

- Important 1:** if there are more command stations connected to the same CANBus network, each command station must have a unique address. The address of the command station is defined by the configuration of the dip-switches.
- Important 2:** “command station 1” and “command station Fast Start-up Mode” cannot co-exist in the same system: either you have a “Fast Start-up Mode” or “Command station 1”.
- Important 3:** to configure the dip-switches of each command station, refer to the installation schemes reported from section 7.1. to section 7.5.
- Important 4:** command station is configured from the factory for systems with only one actuator that can control 2 motors. This is the typical application where there are two motors and two gearboxes with electronic, interface (like it is described in sections 7.4 and 7.5). In case of systems with two mechanical engines and two mechanical gearboxes, you need to use two mechanical actuators (these are the installations described at sections 7.1, 7.2 and 7.3). If this is the case, the command station must be re-configured as described at section 4.4.

## 7.6.2 Configuration of the actuator

To configure the actuator it is necessary to:

- enable or disable the end of line resistor
- define the CANBus address

These operations must be according to the position of the actuator as described in the schemes of chapter 7.

### Actuator PCBoard version 3.1

JP14 defines the CAN Bus address of the actuator. Factory setting is JP14 = OFF (address = 0).

JP19 enables (ON) or disables (OFF) the line termination. Factory setting is JP19 = ON (line termination = ON).

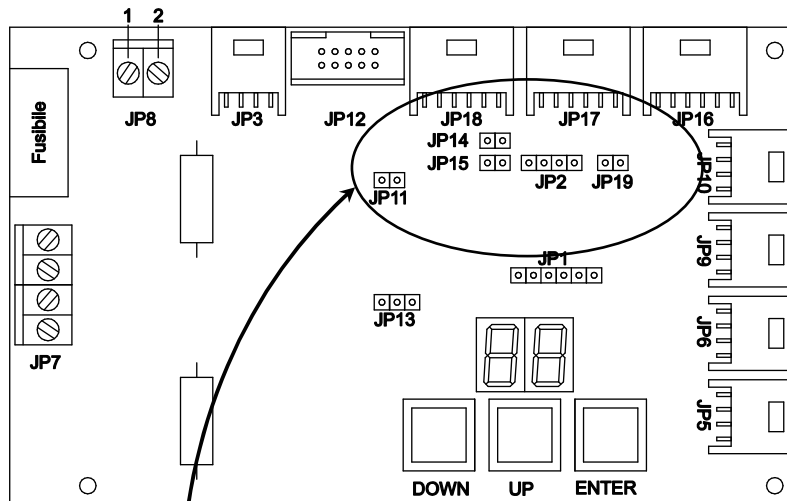

In some documentation, alternative to ON or OFF are indicated YES or NO.



If JP14 = ON, address = 1

If JP19 = ON, end of line is enabled

The actuator configuration changes according if the system is with one or two actuators:

Installations with 1 actuator	Installations with 2 actuators
JP14 = OFF (address = 0)	Left actuator is with JP14 = OFF (address = 0)
	Right actuator is with JP14 = ON (address = 1)
The settings of JP14 and JP19 depend on the configuration of the CANBus network, as described from section 7.1 to 7.5	

## 7.7 Configuration with more than 3 command stations

In case are required more than 3 command stations, command station with address n° 3 must be with serial number greater than 18500. It is then possible to add to the CANBus network an unlimited number of command stations, which must have all the CANBus address n° 3.

Command stations with CANBus address = 3 can be physically placed anywhere in the CANBus network, but the CANBus must have at its ends the end-of-line terminations (see sections from 7.1 to 7.6). Here below an example of a single actuator installation with more than 3 command stations.

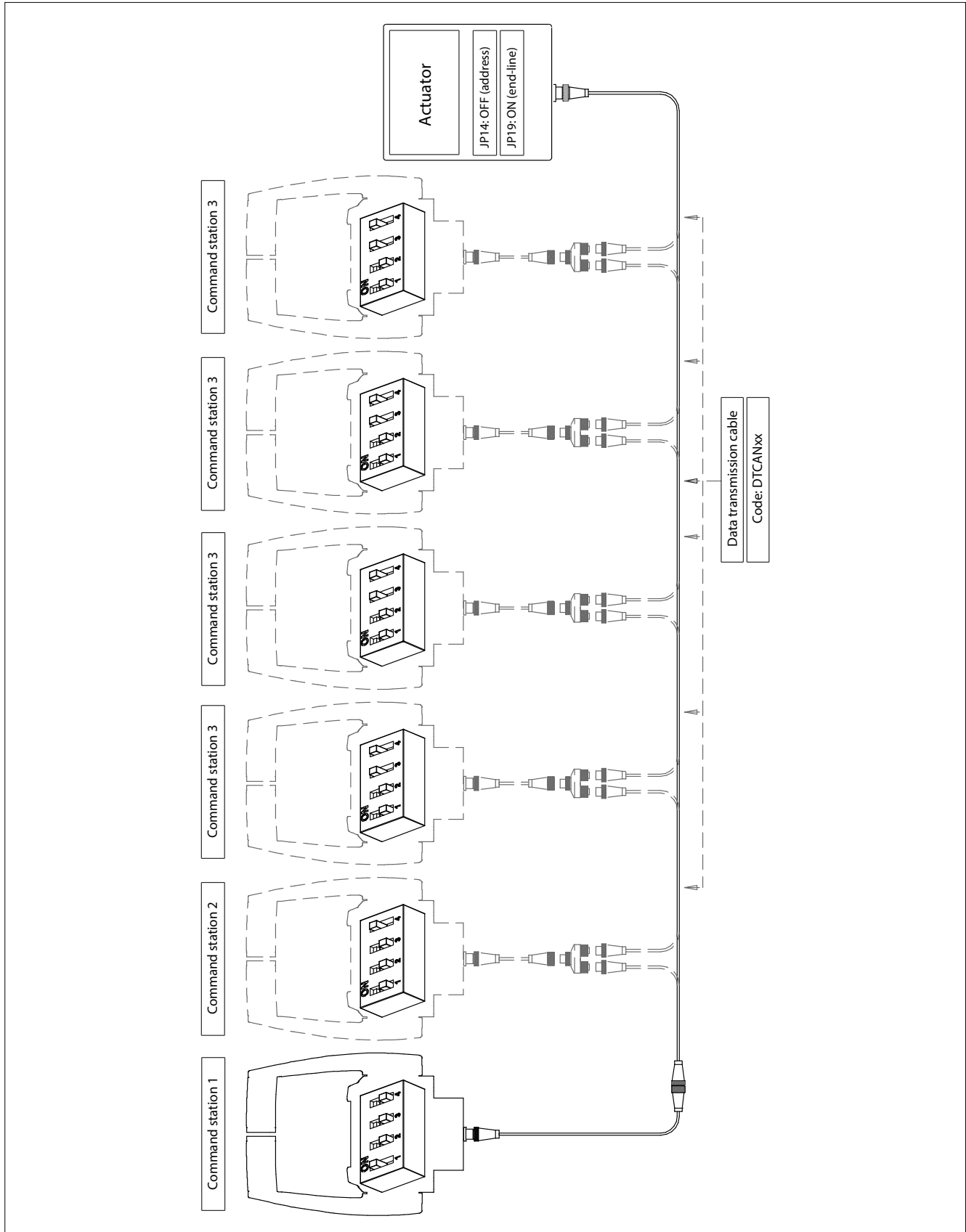

## 8 Electrical installation

**System's components involved:** actuator, supply connector, all the electrical cables

### 8.1 Wiring from the battery to the actuator (input cables)

#### 8.1.1 Supply connector

**First of all you must wire the power supply cable, do not connect any other cable before having checked that this operation has been performed correctly!**

Choose a cable with a cross section of at least 2,5 mm<sup>2</sup>.

Each actuator is delivered with an external supply plug, identify the insert of the power plug.

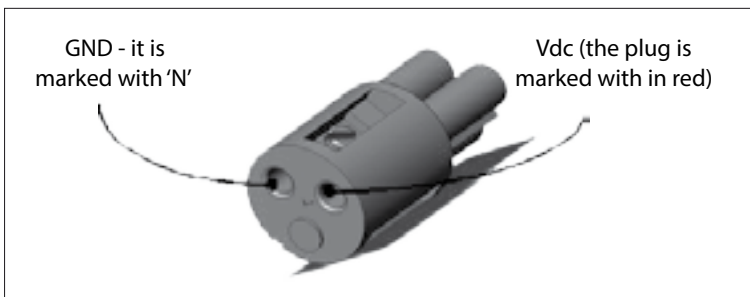

- pay attention that the positive wire must be screwed to the clamp with the red mark
- insert the plug into the connector of the actuator box and power-up
- open the actuator box removing the 4 plastic screws

If the plug has been wired properly, after power up, the display shows a sequence of 2 codes: 'FI' and 'XX':

- 'FI' means Firmware;
  - 'XX' is the firmware version.
- ... and after 2 seconds the display shows " \_ \_".

If the display on the actuator doesn't show any light, it means that there is no power supply on the actuator box.

#### Causes:

- the electrical connection is missing, check where
- the actuator has been supplied with inverse polarity, therefore:
  - swap plus and minus wires, in order to re-establish the right polarity on the supply cable
  - replace the fuse of 6,3 A that you find on the front of the actuator box
  - insert again the plug into the connector of the actuator box and power-up

If the display is lighted, the cabling is correct and you see on the actuator's display the following sequence of digits reported here above (FI XX \_ \_).

In case of installations with 2 actuators, repeat the same procedure on each actuator (check that both displays light on).

**Only after you have assured that the actuators have been powered up correctly, you can connect the CANBus cable between the actuators and all the other electrical cables.**

Supply voltage	12 V	24 V	12/24 V
Internal fuse (on the actuator PCB)		5,0 A	
Wall fuse	6,15 A	-	6,15 A
Current absorbed in no loaded condition	0,5 A	0,25 A	0,5 A (max)

### 8.1.2 The ignition key switch

#### Starter motors

The cables that connect the battery to the starter motors must have a cross-section of at least 50 mm<sup>2</sup> (both the “plus” and the “minus” cable). The “minus” cable of the actuator must be connected directly to the battery. It is vital that there is zero voltage between battery negative terminals.

#### Electronic system with 1 actuator

In case of 2 batteries, the actuator must be connected to both the batteries. The “plus” cables must be connected with a 10A decoupling diode. In this way the actuator will be supplied by the most charged battery. The minimum section of the cable must be of 2,5 mm<sup>2</sup>.

Refer to electrical installation scheme reported in section 8.1.3 for system with one ignition key and 8.1.4 for system with two ignition keys. This last scheme allows to power the actuator box activating at least one of the two ignition keys.  
If your application has double deck (e.g. main deck and fly-bridge) refer to installation scheme reported in section 8.1.5.

#### Electronic system with 2 actuators

Each actuator must be supplied from its own battery. The minimum section of the cable must be of 2,5 mm<sup>2</sup>.

Refer to electrical installation scheme reported in section 8.1.6.  
If your application has double deck (e.g. main deck and fly-bridge) refer to installation scheme reported in section 8.1.7.

### 8.1.3 Electrical installation of systems with 1 engine, 1 actuator and 1 ignition key

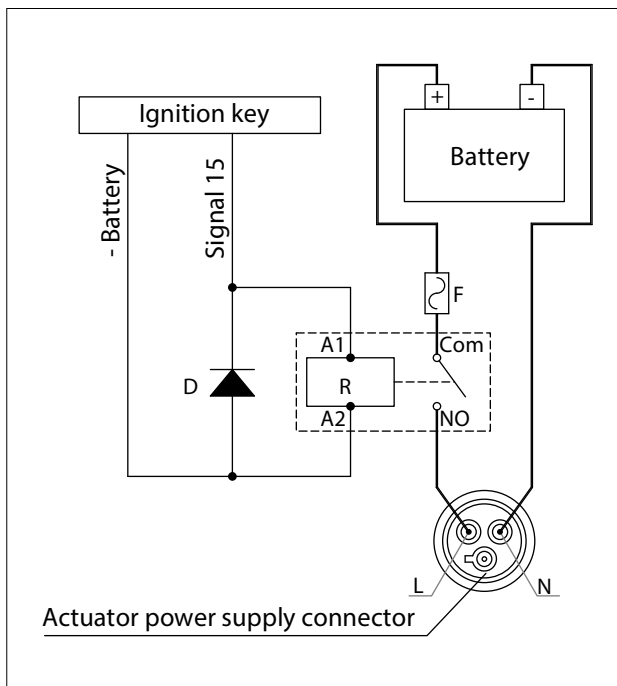

Ref.	Description	12 V power supply	24 V power supply
D	Diode	10 A, 20 V	5 A, 24 V
R	Relay	10 A, 12 V	5 A, 24 V
F	Fuse	10 A	
15	Terminal 15 is the signal coming from the ignition key lock. When the ignition key is on its first detent, signal 15 is active.		
	Supply cable cross section	2,5 mm <sup>2</sup>	1,5 mm <sup>2</sup>



### 8.1.4 Electrical installation of systems with 2 engines, 1 actuator and 2 ignition keys

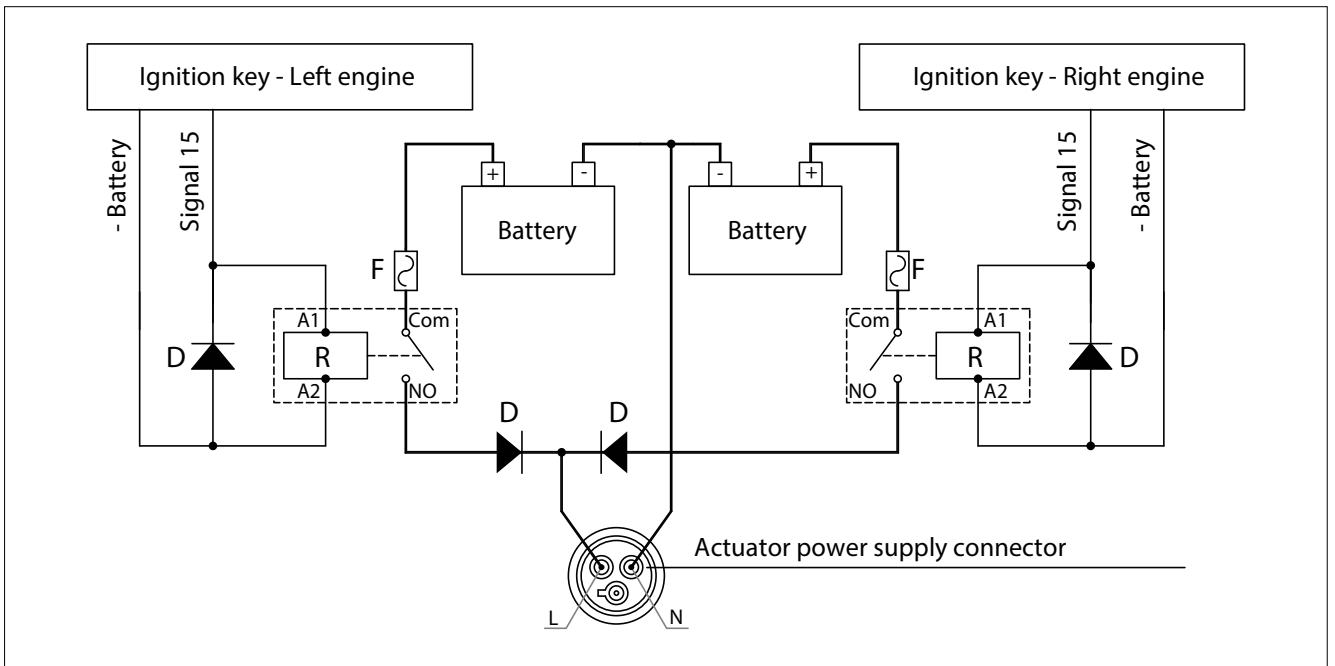

For the detailed list of components, please refer to the table at section 8.1.3.

### 8.1.5 Electrical installation systems with 1 engine, 1 actuator and 2 ignition keys

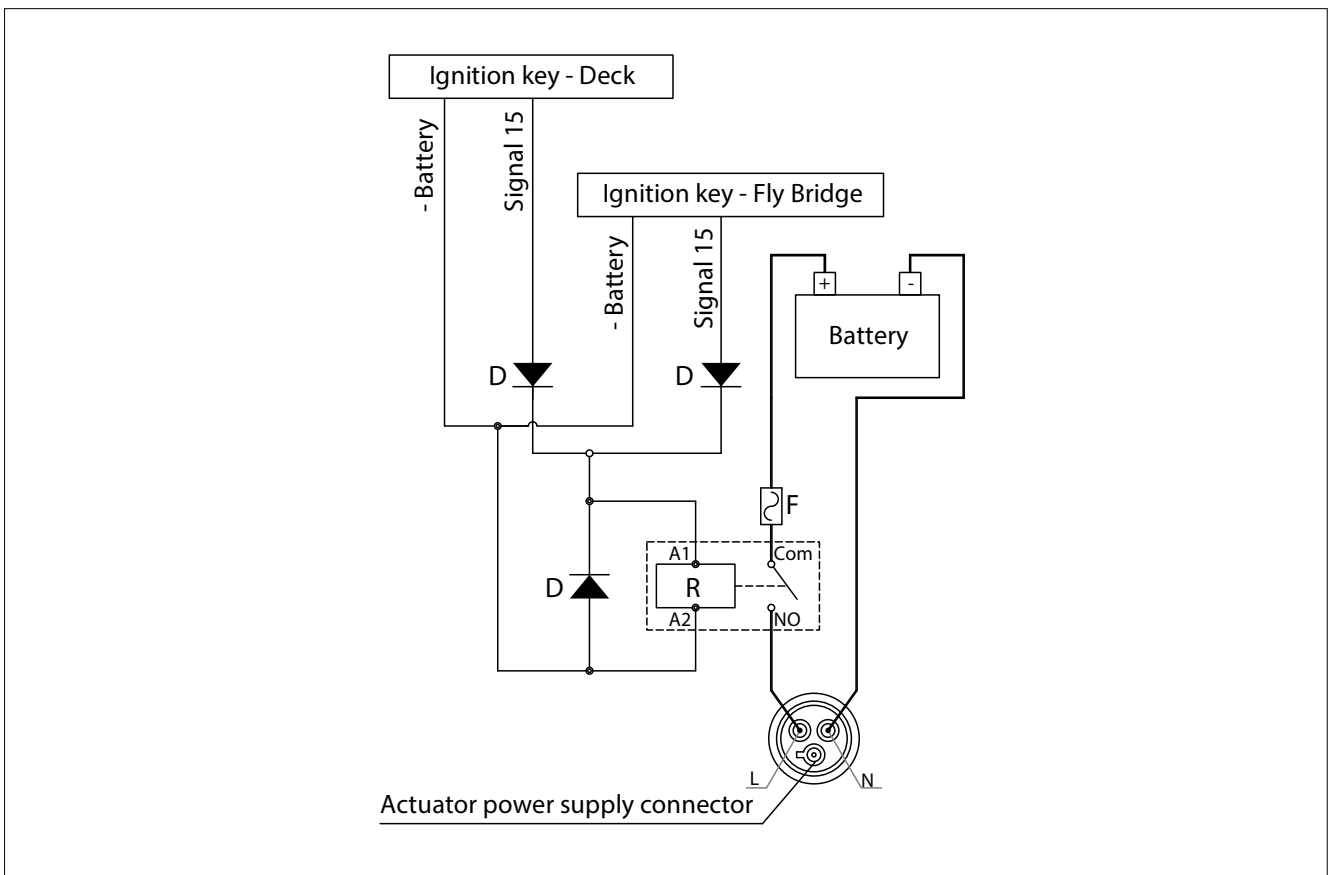

For the detailed list of components, please refer to the table at section 8.1.3

### 8.1.6 Electrical installation of systems with 2 engines, 2 actuators and 2 ignition keys

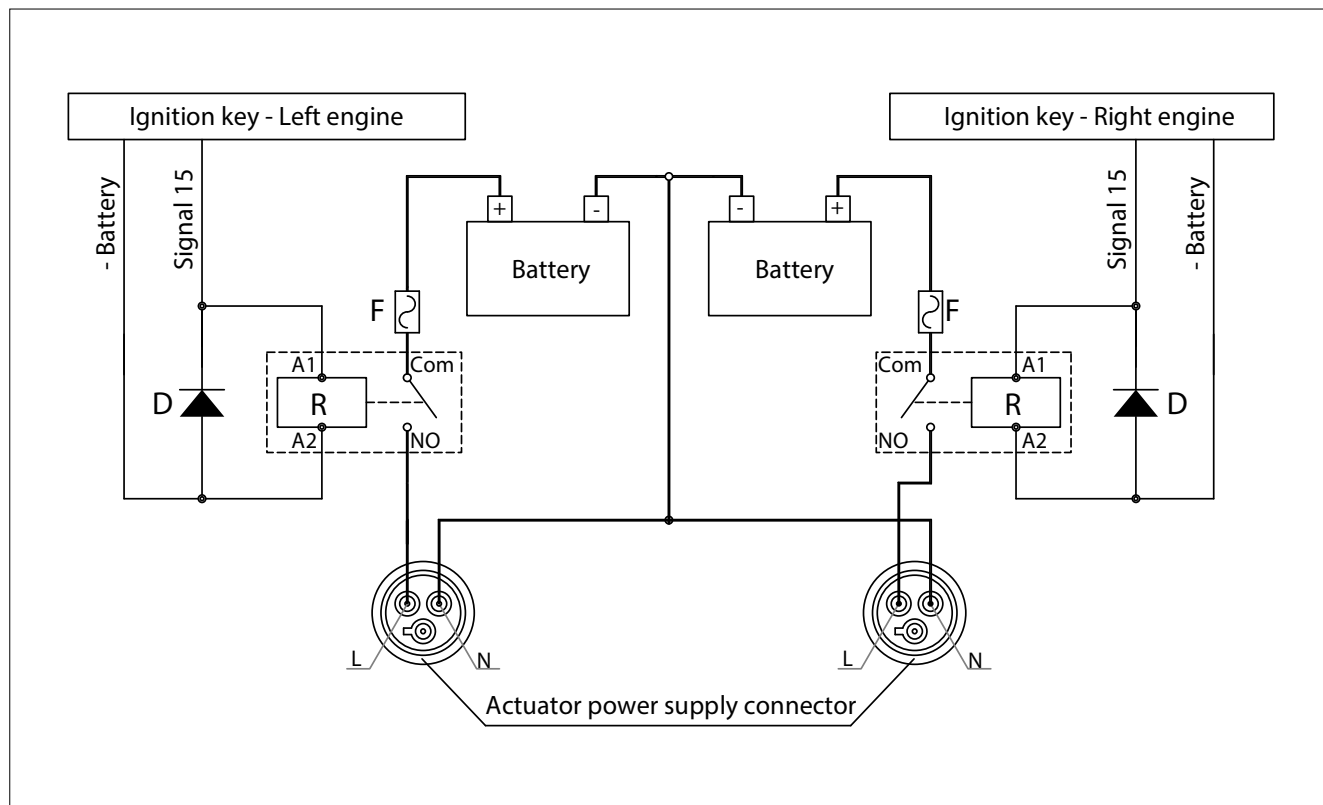

For the detailed list of components, please refer to the table at section 8.1.3.

## 8.1.7 Electrical installation of systems with 2 engines, 2 actuators and 4 ignition keys

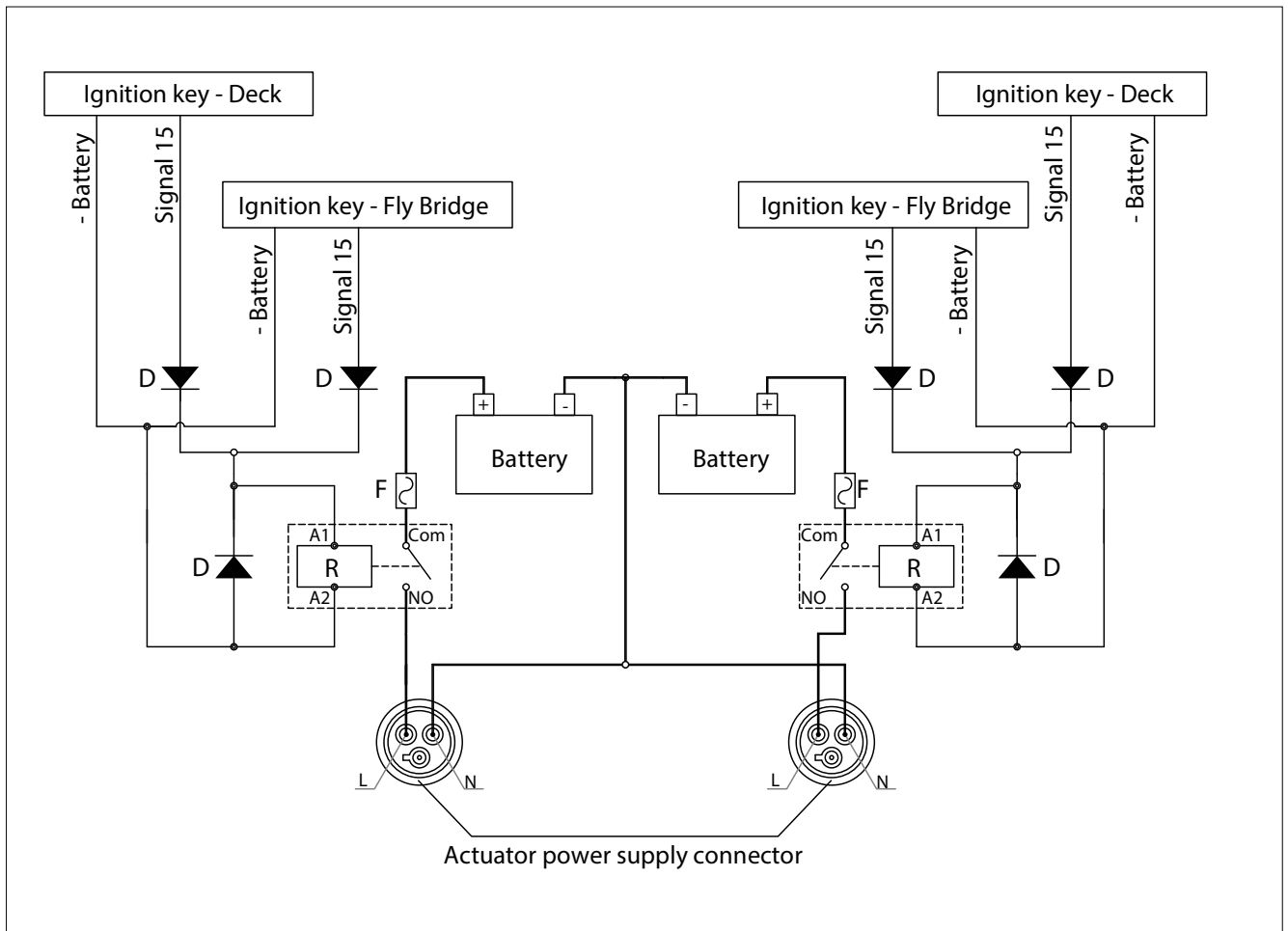

For the detailed list of components, please refer to the table at section 8.1.3.

## 8.1.8 Dimensional criteria of the power supply cables

For the supply cables respect the following provisions:

- Cables from the battery to engine starter (both positive and negative poles) must have a minimum cross section of 50 mm<sup>2</sup>, if it is not specified a higher cross section by the engine supplier.
- The GND of the actuator must be connected directly to the negative pole of the battery. Minimum cross section is 2,5 mm<sup>2</sup>.
- In case electronic throttle, it is very important to connect to a common GND point (either GND bus bar or common bonding conductor or hull) all the negative poles of each electronic device.

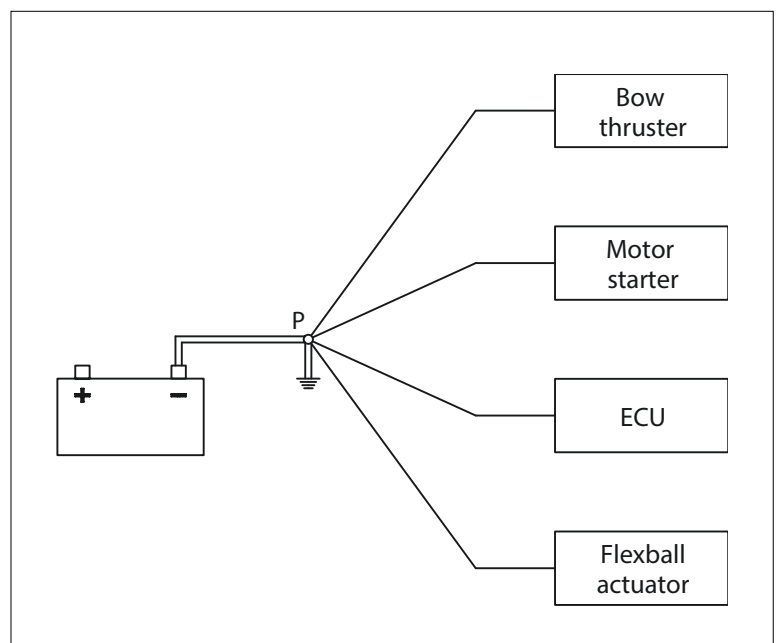

## 8.2 Wiring from the actuator to command stations, engines, gearboxes, trim/flaps, etc (output cables)

Almost every cable is provided with its unique connector, therefore it is easy to identify the cable type, its function and where to mount it. Each connector has a different polarization, so it is almost impossible to mount a cable in the wrong position. For the description of all the types of cables, look at chapter 6.

**When mounting the electronic engine cable on the actuator:** align the polarization keys and insert carefully the M12 connector of the cable on the actuator M12 counterpart. Rotate then the M12 ring until the cable enters completely into the counterpart. If the cable has been inserted correctly, it must be possible to screw completely by hand the cable without too much efforts (around 6 full rotations). For more info look at chapter 6.

There are basically 4 types of actuators classified on the type of interface (mechanic or electronic) and on the type of connector placed on the actuator itself (with or without neutral relay).

### 8.2.1 Actuator with mechanical interface without neutral relay

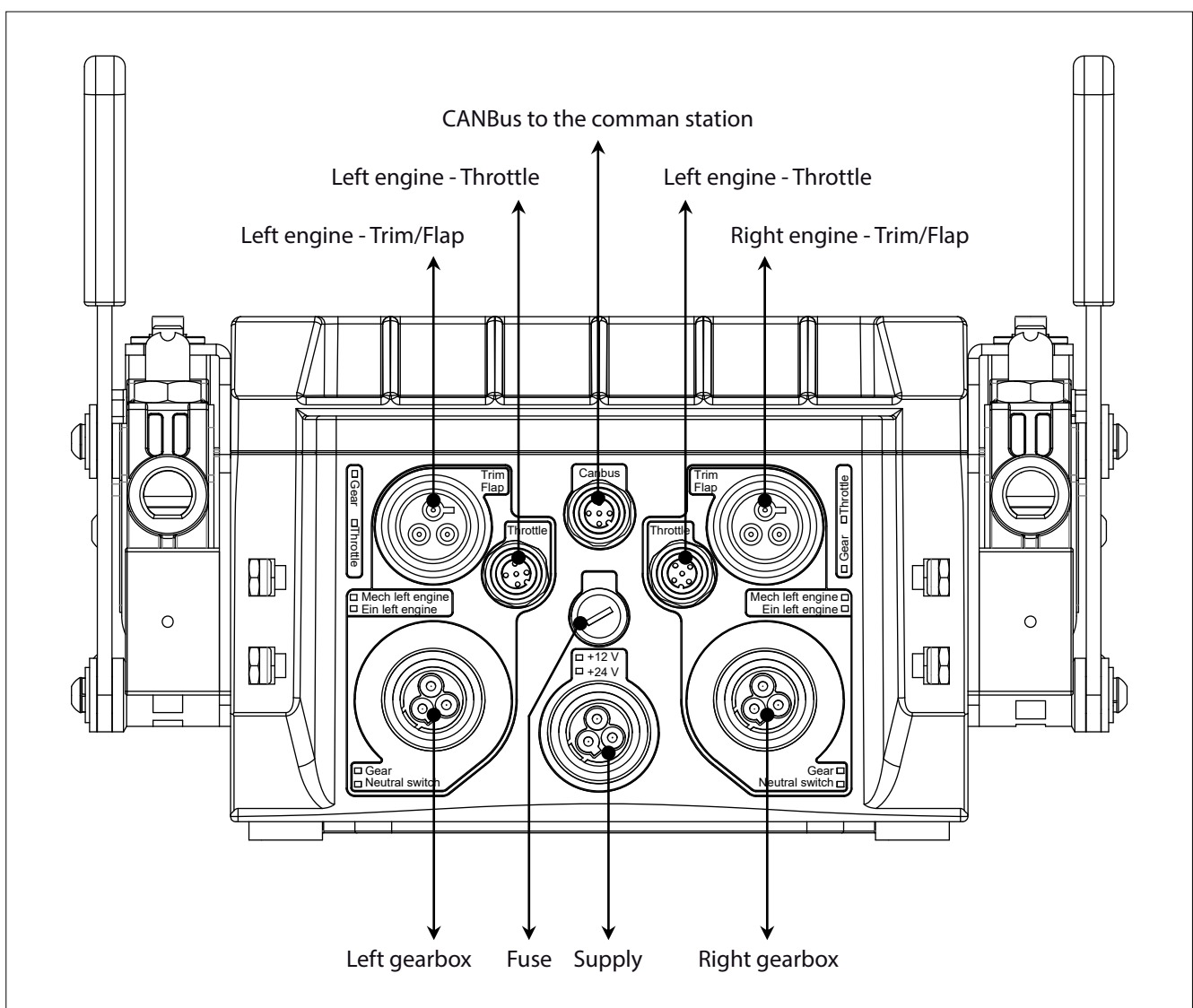

For better comprehension are depicted only the electrical connections and not the mechanical linkages. This actuator is available in versions with neutral relay, with or without trim and it is suitable for the following applications:

- mechanical engine and mechanical gearbox (only 1 propulsion group per actuator)
- mechanical engine and solenoid driven gearbox (2 propulsion groups per actuator)
- electronic engine and mechanical gearbox (2 propulsion groups per actuator)

## 8.2.2 Actuator with mechanical interface and neutral relay

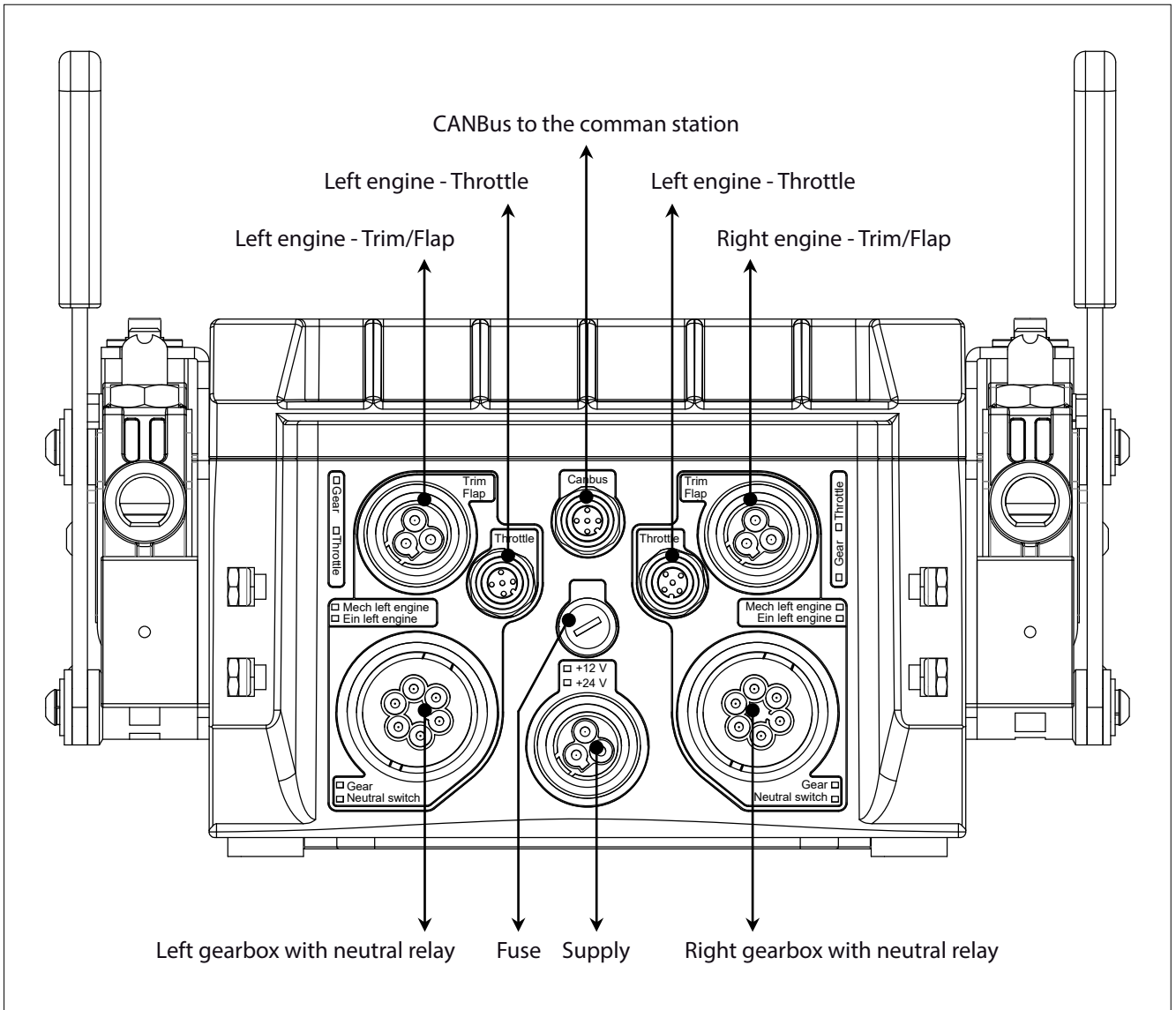

For better comprehension are depicted only the electrical connections and not the mechanical linkages. This actuator is available in versions with neutral relay, with or without trim and it is suitable for the following applications:

- mechanical engine and mechanical gearbox (only 1 propulsion group per actuator)
- mechanical engine and solenoid driven gearbox (2 propulsion groups per actuator)
- electronic engine and mechanical gearbox (2 propulsion groups per actuator)

### 8.2.3 Actuator with full electronic interface

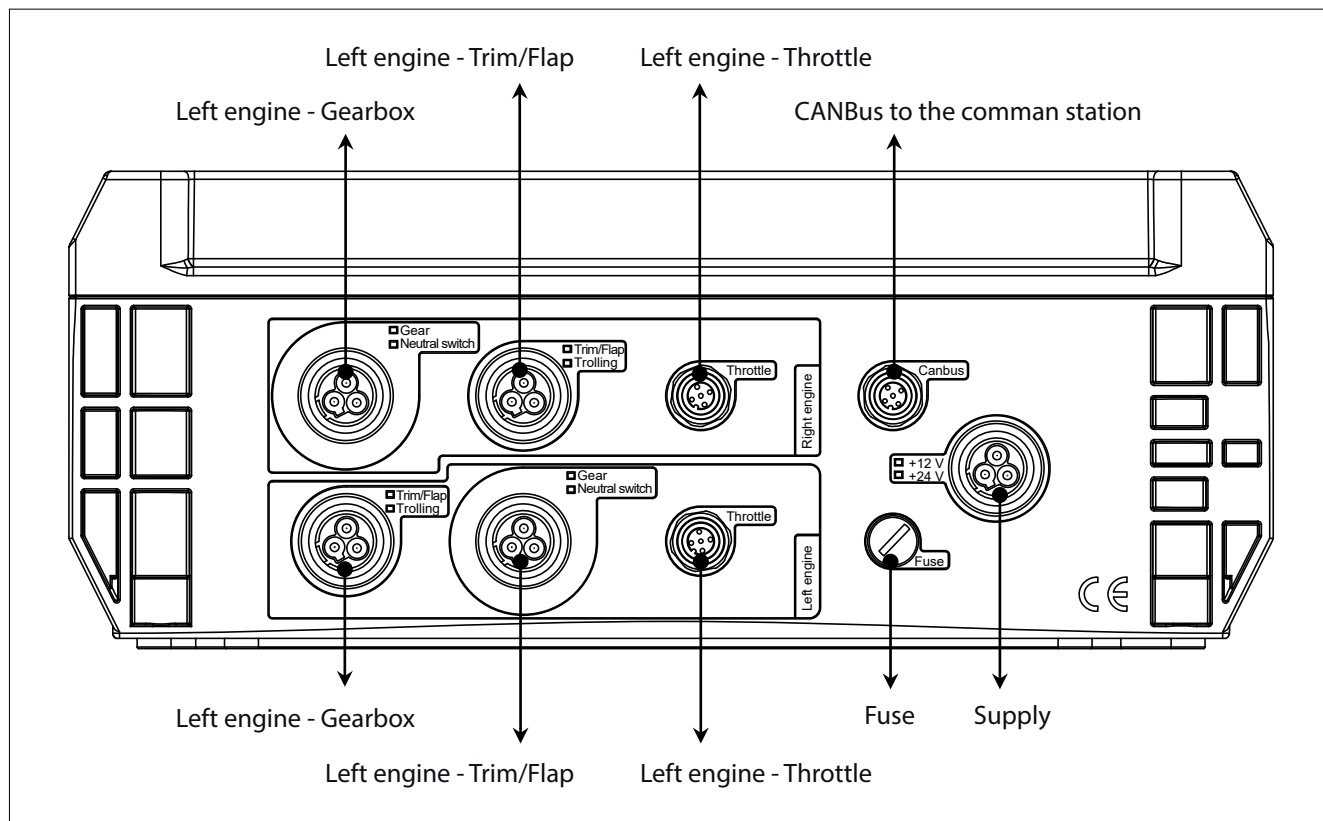

**Important:** in case of single engine installation, use only the connectors for the right engine.

### 8.2.4 Actuator with full electronic interface and neutral relay

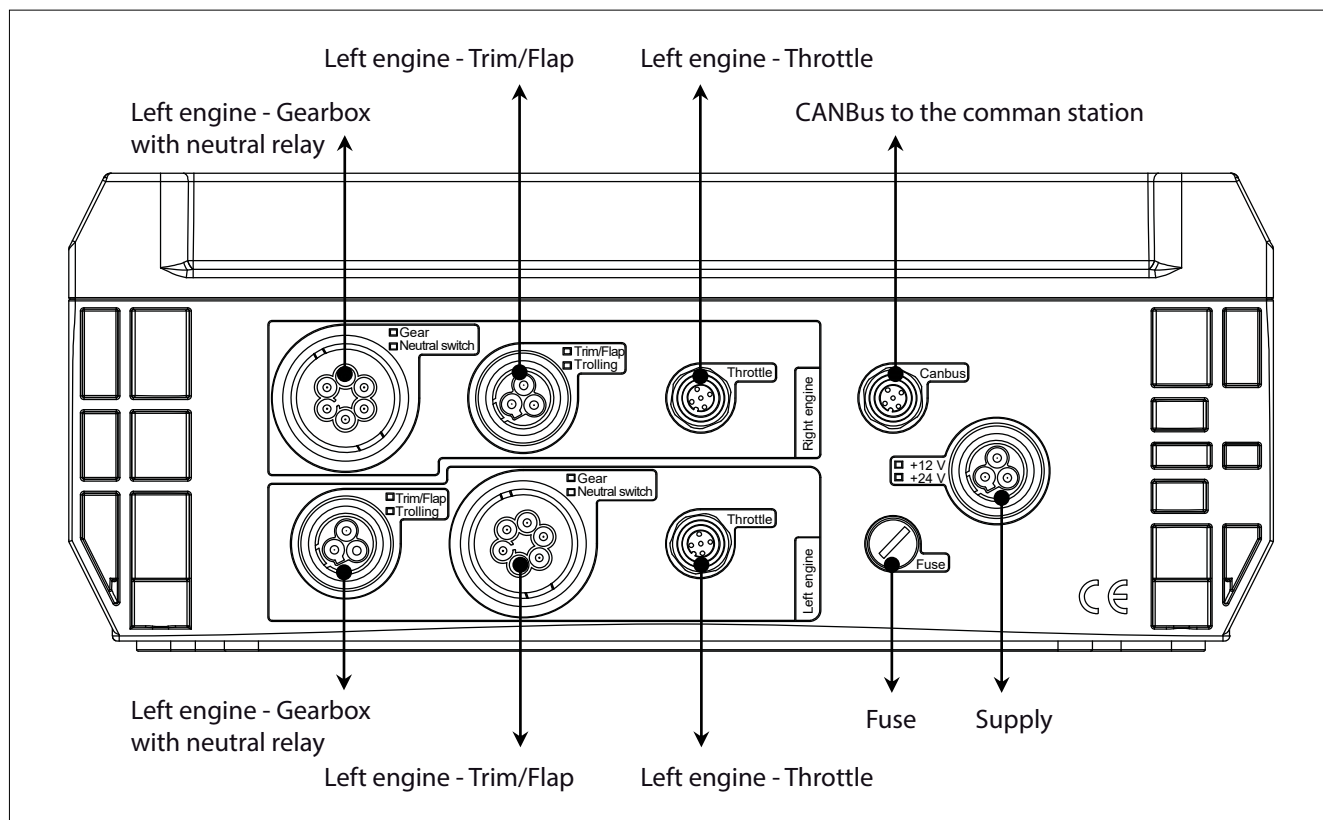

**Important:** in case of single engine installation, use only the connectors for the right engine.

## 8.2.5 Wiring scheme to gearbox in case of actuator without neutral relay

This wiring scheme refers to:

- Actuators without neutral relay (see sections 8.2.1 and 8.2.3)
- Gearbox cable code EC3T2 (see section 6.3), gearbox cable code 4665/36 (see section 6.3.1) and gearbox cable code 15/36 (see section 6.3.2)

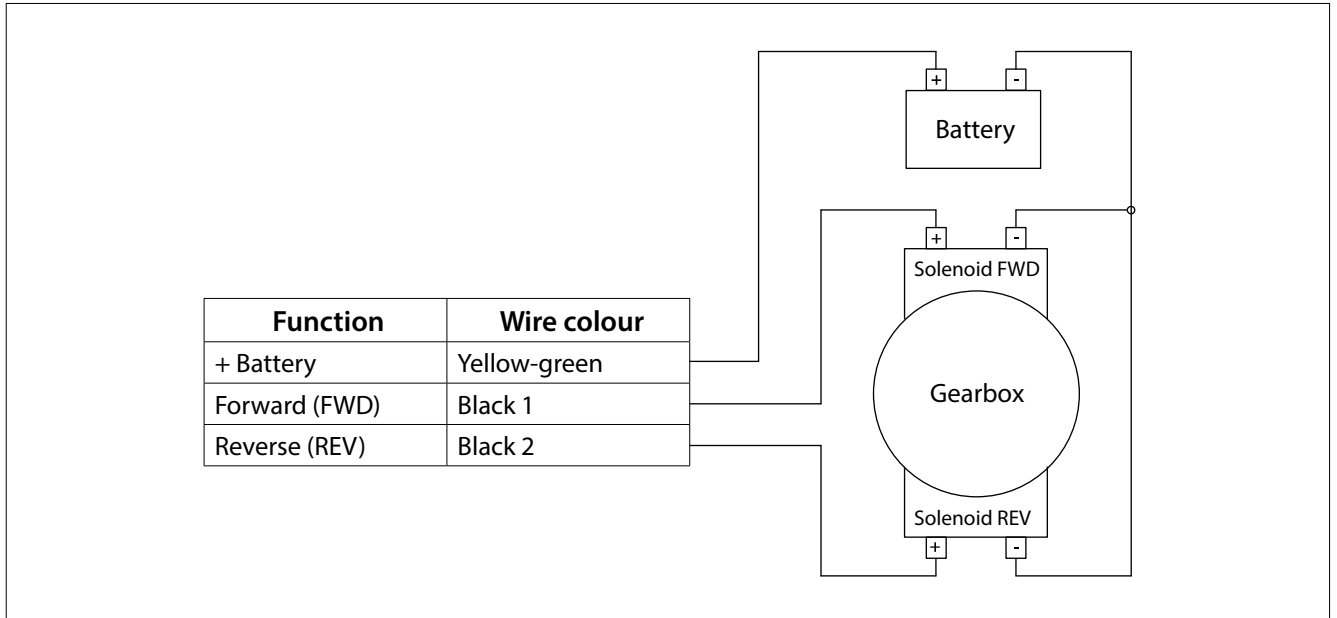

**Important:** this scheme shows how to connect the electrical cables; battery switch and protection devices (e.g. fuses) must be chosen according to local regulations.

## 8.2.6 Wiring scheme to gearbox in case of actuator with neutral relay

This wiring scheme refers to:

- Actuators with neutral relay (see sections 8.2.2 and 8.2.4)
- Gearbox cable code ECG3/6 (see section 6.3.1)

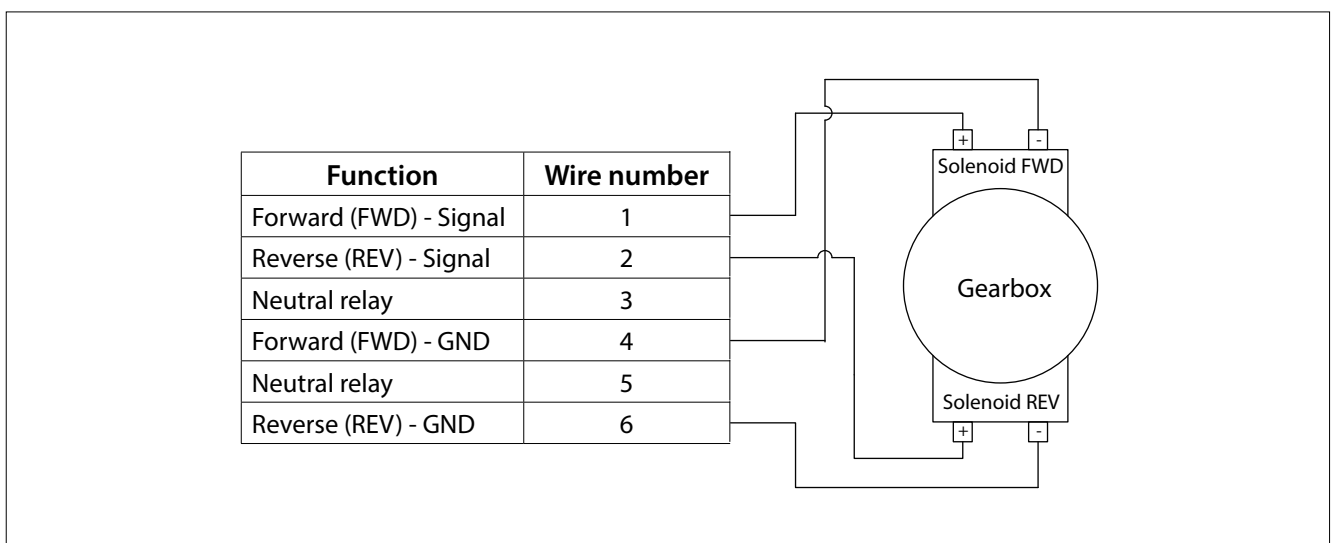

**Important:** this scheme shows how to connect the electrical cables; battery switch and protection devices (e.g. fuses) must be implemented according to local regulations.

### 8.2.7 Wiring scheme from actuator to trim/flap with external supply

This wiring scheme refers to:

- Any actuator with serial number before 16500
- Trim/Flap cable code EC3T3M (see section 6.4)

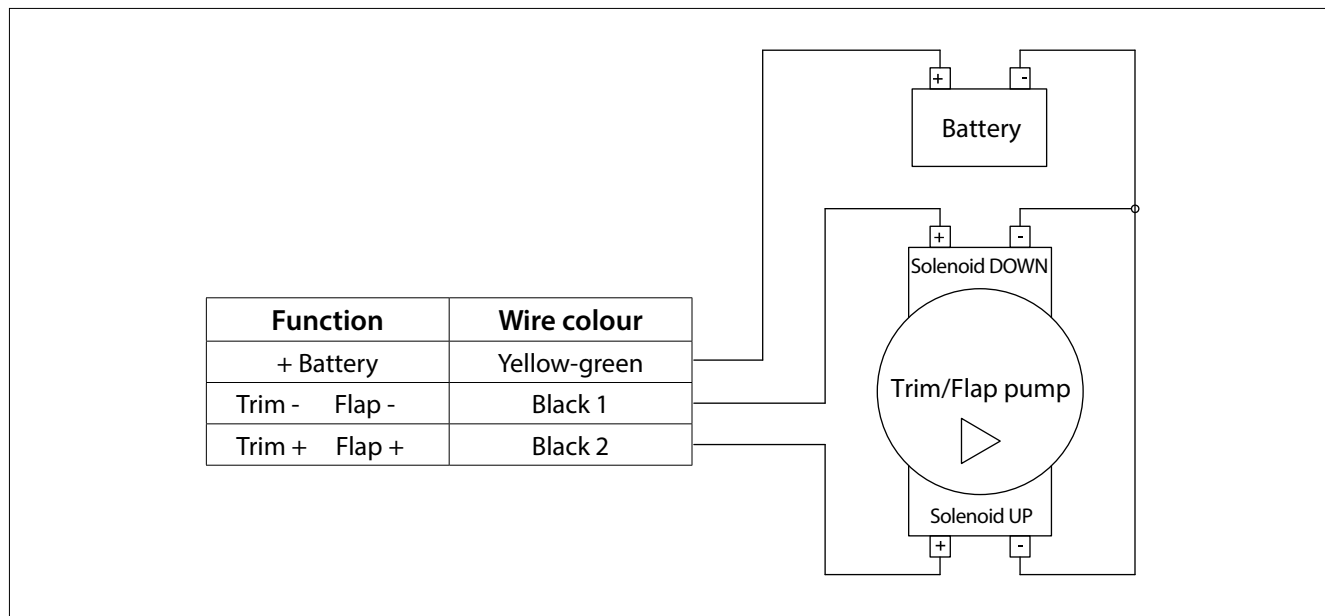

**Important:** this scheme shows how to connect the electrical cables; battery switch and protection devices (e.g. fuses) must be implemented according to local regulations.

### 8.2.8 Wiring scheme from actuator to trim/flap with internal supply

This wiring scheme refers to:

- Any actuator with serial number equal or after 16500
- Trim/Flap cable code EC3T3M (see section 6.4)

Output signals are internally protected with 5A fuse.

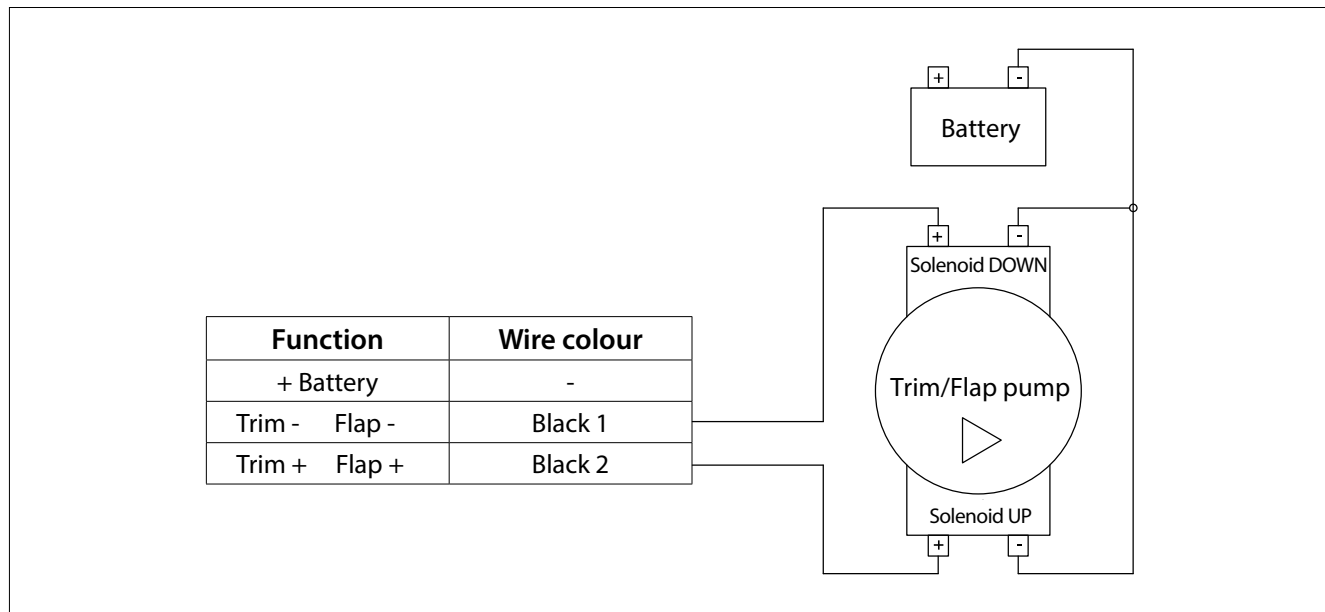



## 9 Programming of the actuator, general guidelines

### 9.1 Programming keypad

The keyboard has a display with two figures and three programming pushbuttons/keys.



Actuators are already programmed from the factory and it should not be necessary to make any change, but in case you want to modify their programming, follow this procedure.

### 9.2 Display and Parameters

After power up, the display shows a sequence of 2 codes: 'FI' and 'XX':

- 'FI' means Firmware;
  - 'XX' is the firmware version.
- ... and after 2 seconds the display shows " \_ \_ ".

To enter into the parameter menu, press at the same time keys "UP" and "DOWN". It is now possible to move from one parameter to the other using the keys "UP" and "DOWN".

For the setting of the specific parameters follow this procedure:

1. with the actuator turned on (the display shows " \_ \_ ") press both keys "UP" and "DOWN" and the first parameter will appear on the display the message "A0"
2. pressing either "UP" or "DOWN" it is now possible to scroll the parameter's list
3. pressing the key "ENTER", the parameter's value will be shown on the display. The display is now blinking and it is possible to modify the parameter's value, using the keys "UP" and "DOWN"
4. press the key "ENTER" to store the parameter's value and immediately the display stops blinking
5. to set the other parameters, scroll the menu with the keys "UP" and "DOWN" and when you have pointed the parameter that you want to change, repeat this procedure from point 3.

### 9.3 Actuator parameters

Parameters are different in relation of the type of actuator and application. The detailed parameter list for each application is described in the specific section reported in the following pages. Here below are listed the parameters common for any type of actuator.

Code display	Description	Range	Factory value	Value shown on display (factory value)	Note
A0	Push-pull cable movement direction	1 .. 4	4	04	
dI	Delay before disengaging the gearbox	0 .. 9.9 s	0.0 s	00	
dA	Delay on the throttle	0 .. 9.9 s	0.0 s	00	
CC	To be used for the check-up of the internal CANBus communication				

A0 is described in section 11.2

With parameters dI and dA it is possible to set a delay time measured in tens of seconds:

- dI is the delay that occurs when you move the lever from forward (or reverse) to neutral. The actuator goes to neutral only after the time set into dI expires.
- dA is the delay that occurs when you move the lever from neutral to forward (or reverse). The actuator starts to accelerate only after the time set into dA expires.

With parameter CC you can check if the communication between the command station and the actuator is correct. The value of the parameter corresponds to a precise physical position of the lever and it is described in the following table:

Value shown on display	Description
N	indicates that the command station is in neutral position
F	indicates that the command station is in forward position
R	indicates that the command station is in rear position
1-2-3-4-.....9-A	indicates that the command station is in throttle condition: "1" is the position of minimum gas and "A" is the position of maximum gas

Looking at the display like in the picture here below, the left digit of the display shows the position of the left command station and the right digit of the display shows the position of the right command station.

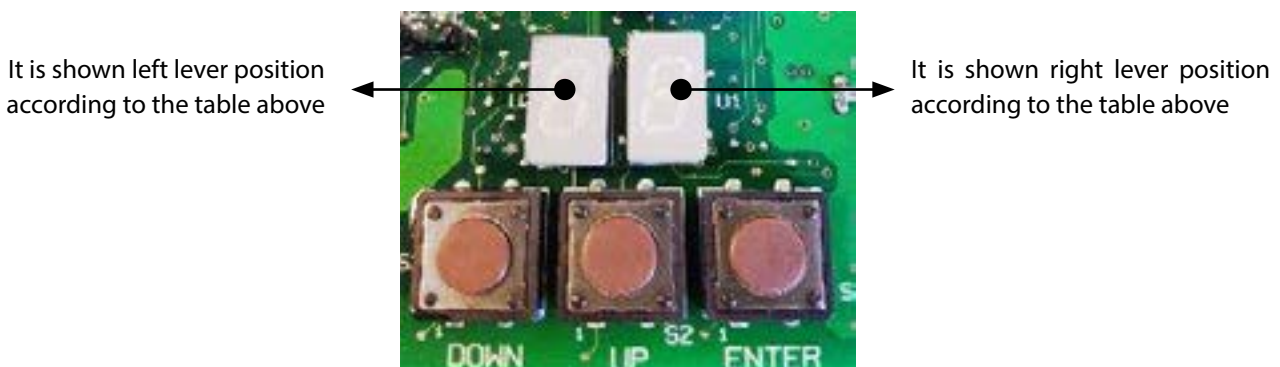

# 10 Installation of the push-pull cable and stroke's programming on the actuator



**System's components involved:** push-pull cables, actuator

In this chapter will be presented the different types of push-pull cables and how to mount them.

## 10.1 Push-pull cables choice

It can be used 3 different types of push-pull cables. For the connection of the push-pull cable to the actuator, it is necessary to use its proper connection kit. The available kits are for Volvo® cable (E2, E3, C0, C3, C33...), Johnson® cable and Mercruiser® stern drive cable.

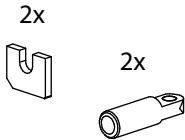
### 10.1.1 Connection kit

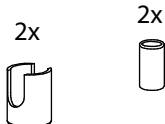
Connection kit for Volvo® cable, or cable type E2, E3, C0, C3, C33...	Connection kit for Johnson® cable	Connection kit for Mercruiser® cable
		

Each kit is enough to connect two push-pull cables.

### 10.1.2 Standard push-pull cable

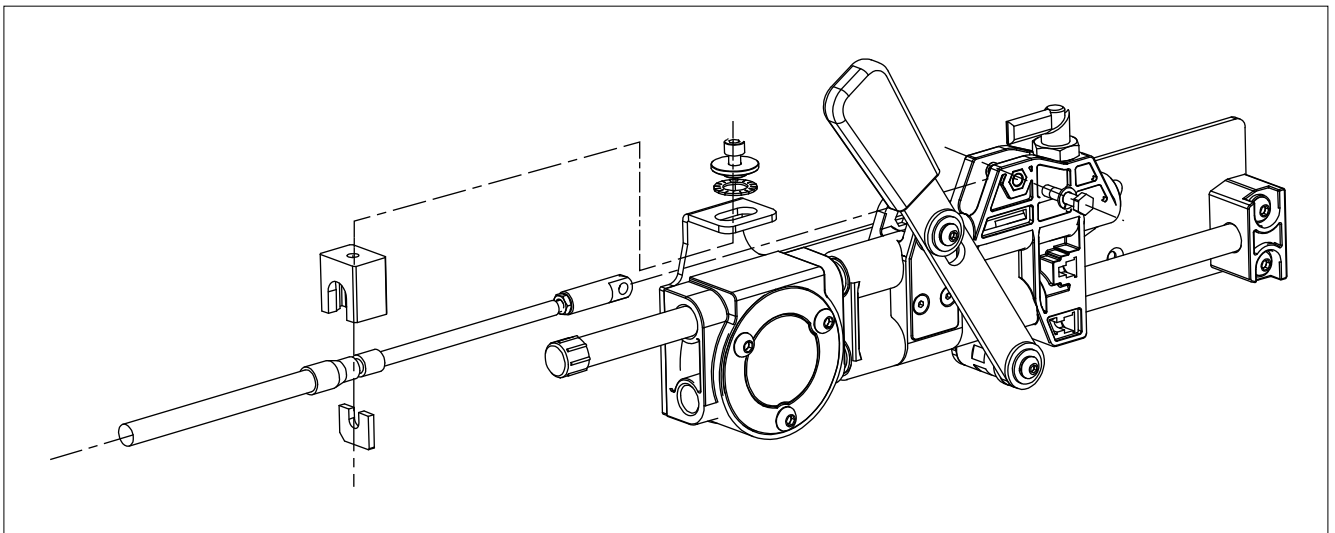

### 10.1.3 Mercruiser® stern drive push-pull cable

In case it is used the push-pull cable to connect directly the actuator to the Mercruiser® stern drive, the plastic Mercruiser® bracket is not necessary.

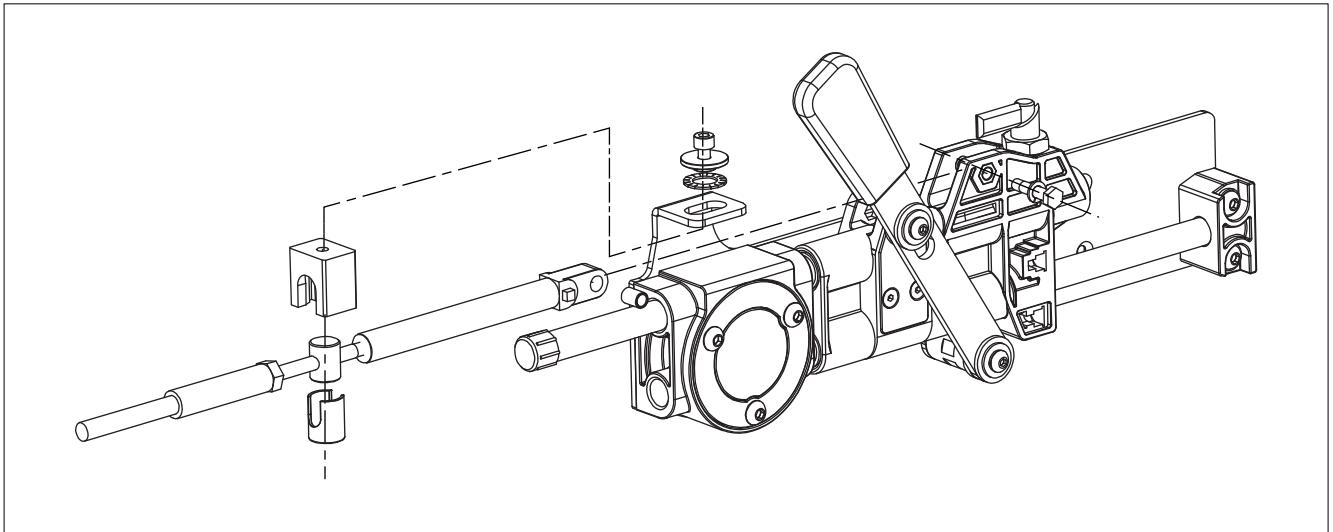

### 10.1.4 Johnson® push-pull cable

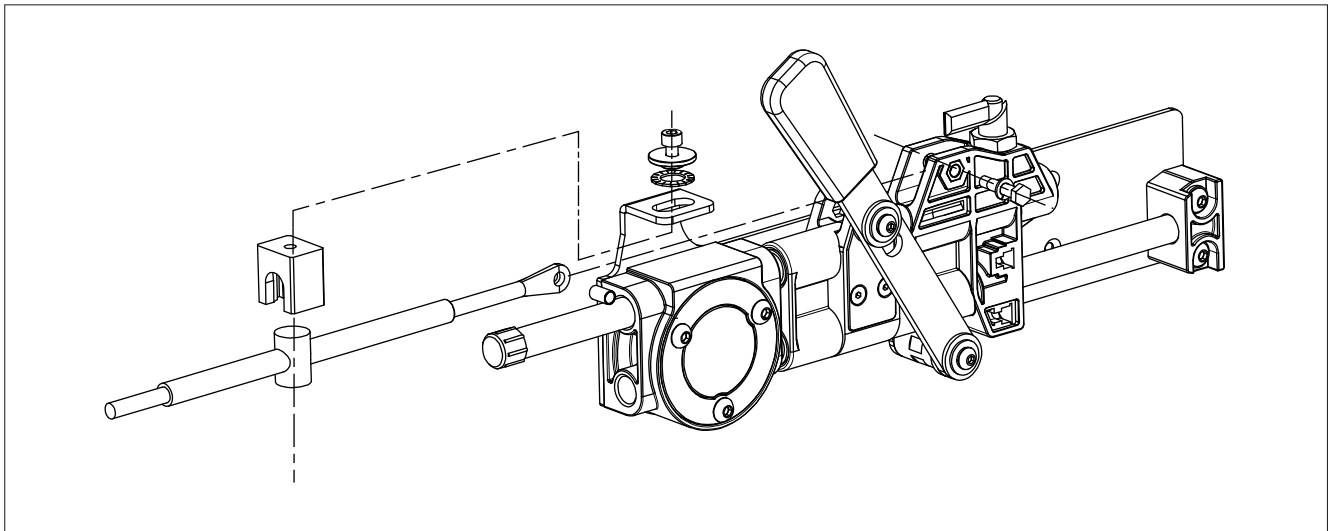

## 10.2 Mounting of the push-pull cables between engine and actuator

This example is referring to the mounting of a standard push-pull cable. To mount the other types of cables, refer to the drawings at sections 10.1.3. and 10.1.4. For the assembly, the throttle must be in minimum position and the actuator must be turned off.

### 10.2.1 Connection of the push-pull cable to the engine

In this example it is assumed that if you pull the cable, the throttle speed increases.

1. Adjust the fixing of the push-pull cable in such a way that when the lever is at the minimum position (engine idle), the rod of the cable is completely out (minimum engine speed).
2. Connect the push-pull cable to the engine throttle lever with the fork or the ball joint.

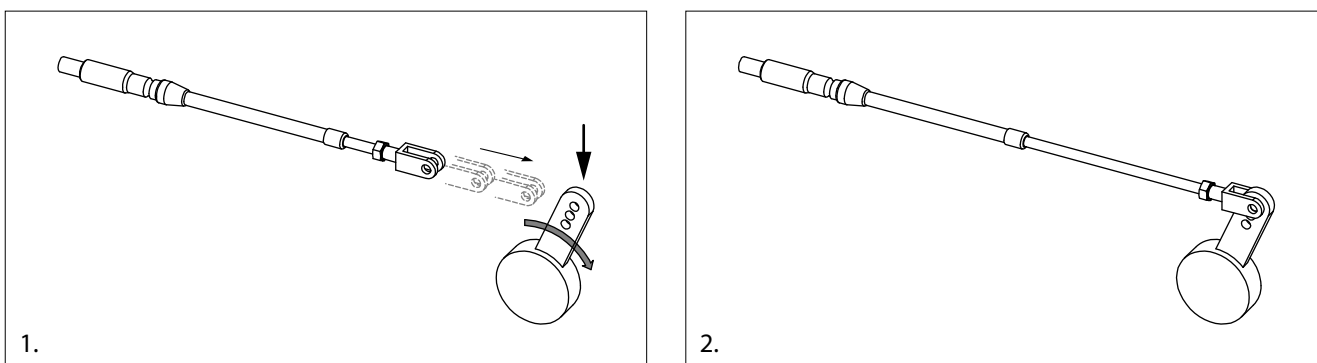

### 10.2.2 Connection of the push-pull cable to the actuator

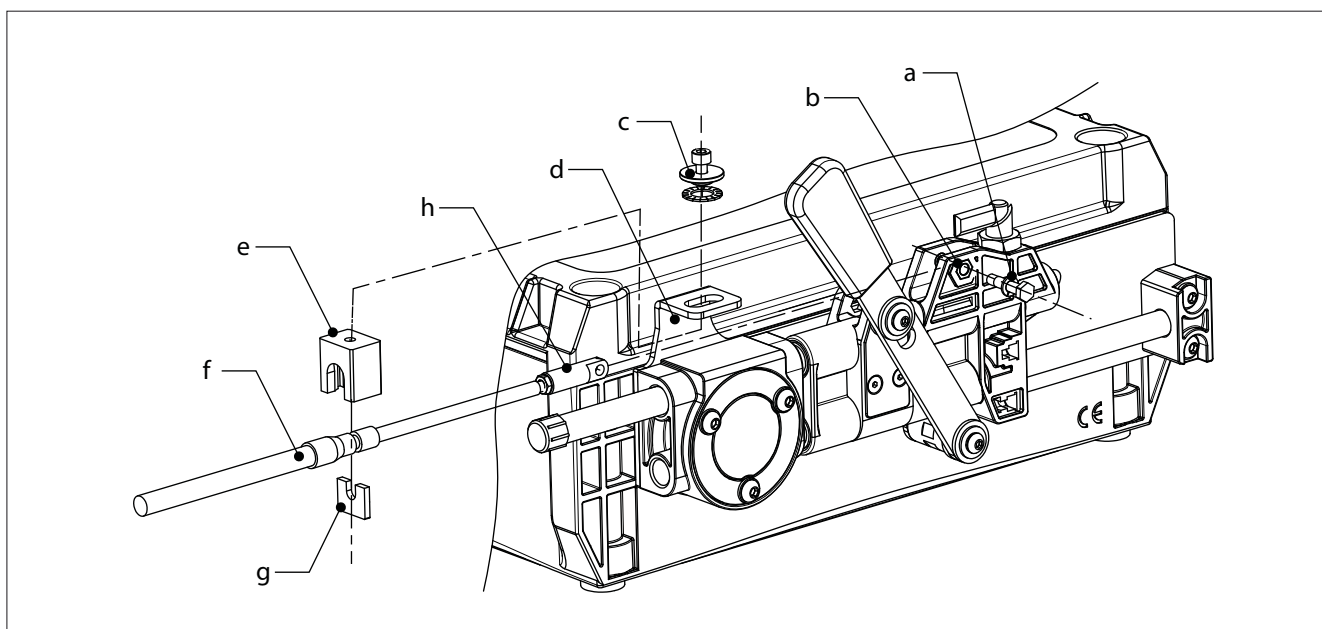

Elements to be used for the connection

a	Screw + elastic washer to connect the eyelet	e	Black aluminium cube
b	Hole where to fix the eyelet	f	Push-pull cable
c	Fixing screw (screw and washers)	g	Blade
d	Bracket slot	h	Eyelet

Follow the steps from 1 to 8 as reported here below:

1. Verify that the actuator's throttle lever is at minimum position, as depicted in the picture here below (1). The lever should be at 10 mm from the eyelet, otherwise enter into the jog programming mode and move the actuator's lever to this position. For this operation follow steps from 1 to 7 section 11.1. The minimum speed throttle position is parameter "UL".
2. Verify that the position of the throttle lever is in idle position on the motor side as described at section 8.2.1. If this is the case, at the actuator side the rod should be inside the push-pull cable (minimum stroke cable condition). Then screw the eyelet (h) onto the cable's rod (2).

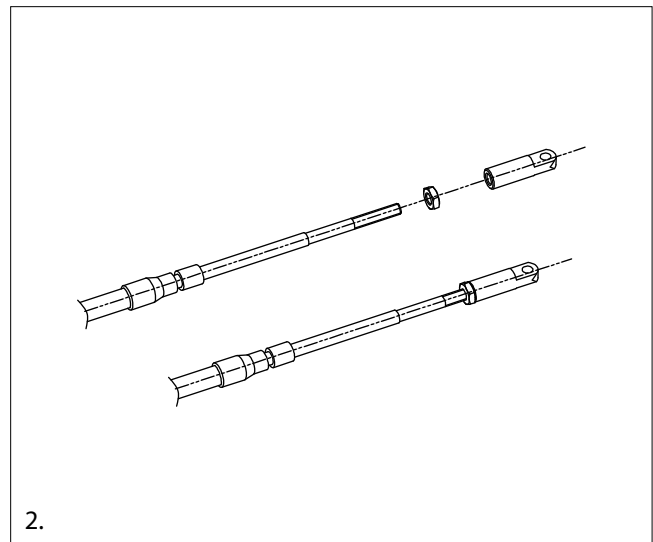
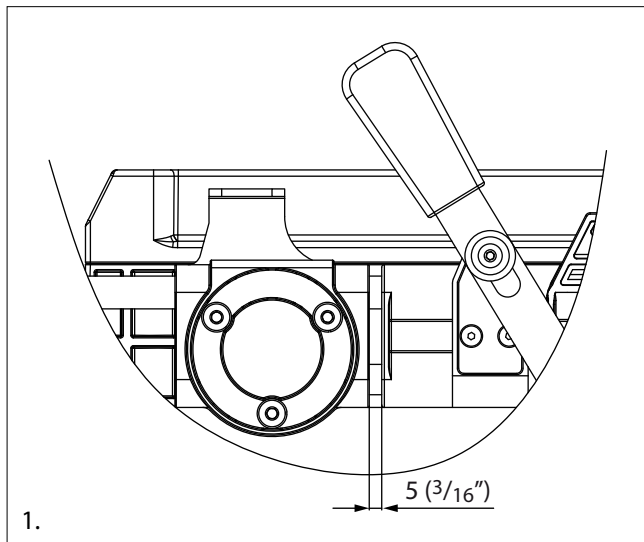

3. Align the eyelet on the push-pull cable (H1) with the hole of the plastic slider (H2). Insert the screw (+ elastic washer) and fasten it.

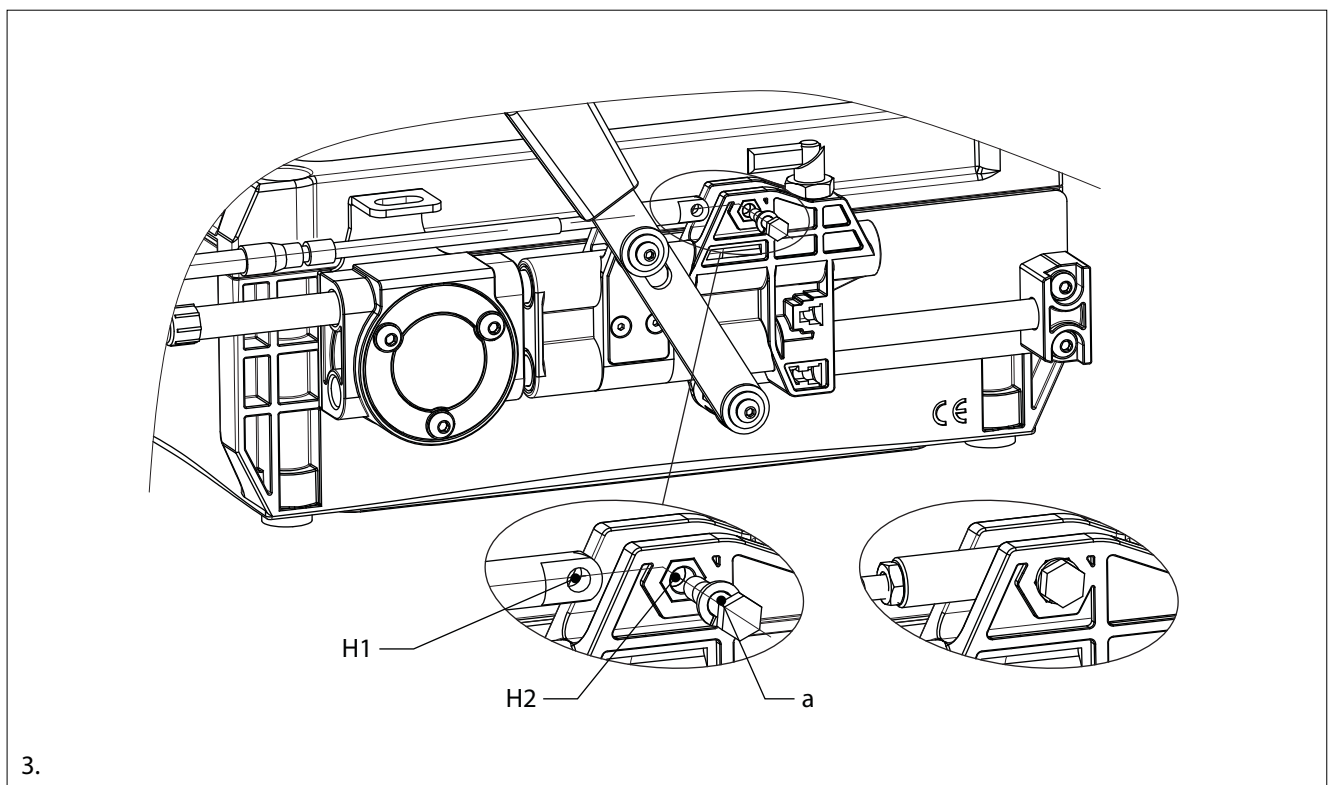

4. Insert the groove of the push-pull cable fitting between the blade (g) and the black aluminium cube (e).

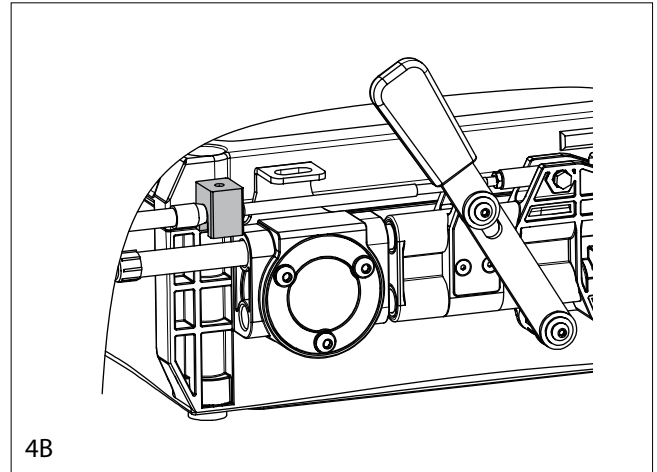
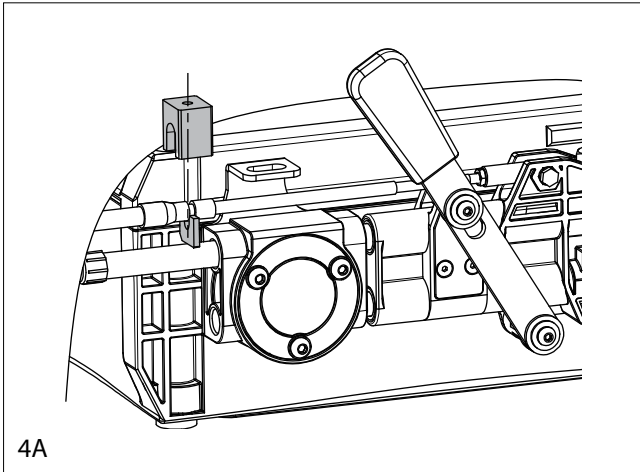

5. Insert the push-pull cable into the slot of the bracket (d). Check that the fixing cube is centred with respect to the slot on the bracket.

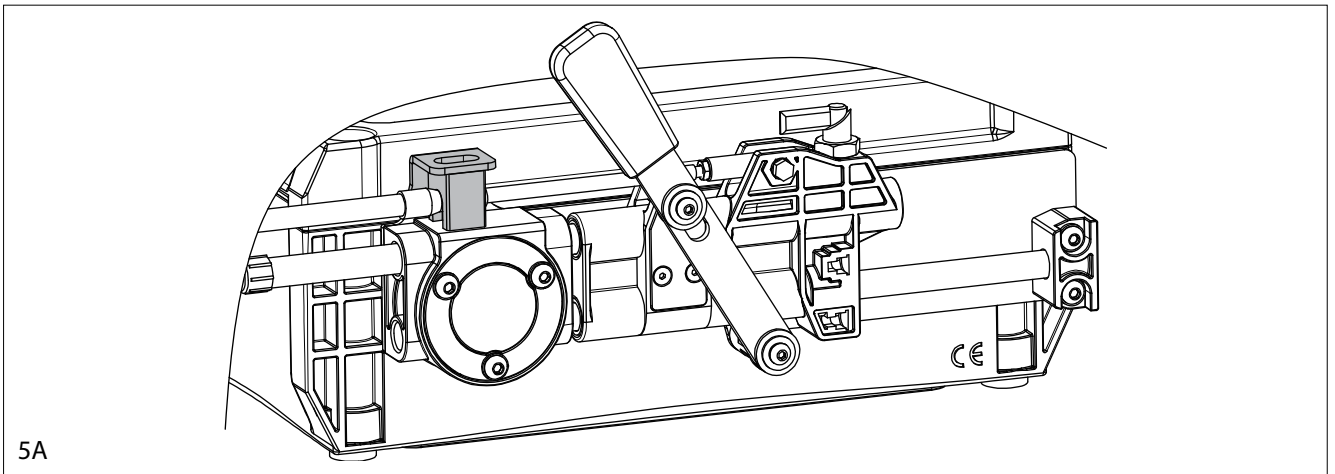

6. Fix the black aluminium cube (e) against the bracket (d) using the fixing screw (c).

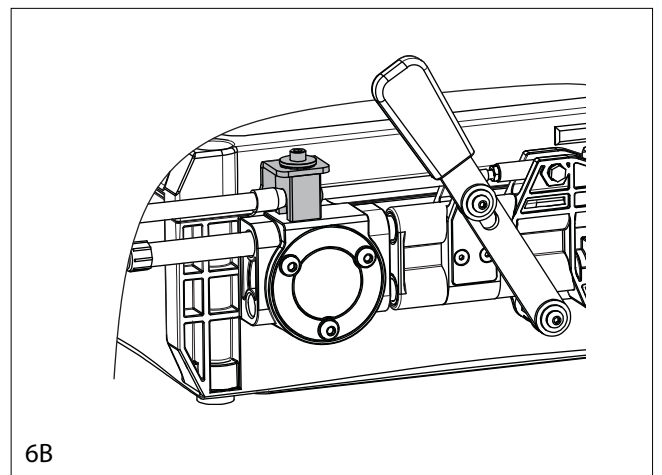
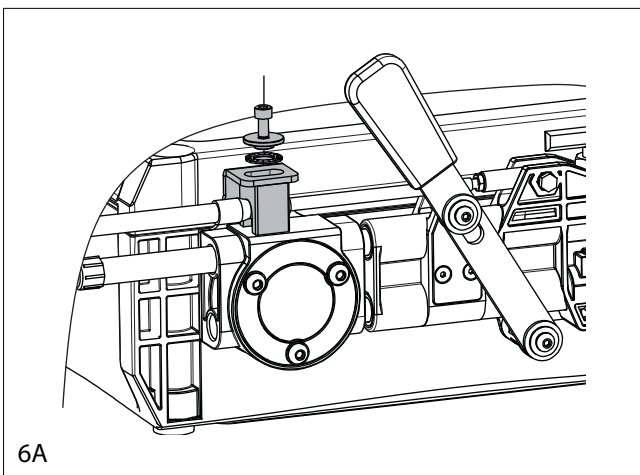

7. If the fixing position is not correct, tune the push-pull cable in such a way that when the cable is at its minimum, the fixing screw is aligned with the notch on the slot.
8. Verify and eventually tune again minimum speed position (UL) and set maximum speed position (UH). For these operations look at section 11.1

### 10.3 Mounting of the push-pull cable between gearbox and actuator

This example is referring to the mounting of a standard Volvo Penta push-pull cable. To mount the other types of cables, refer to the drawings at sections 10.1.3. and 10.1.4. For the assembly, the gearbox must be in neutral position and the actuator must be turned off.

#### 10.3.1 Connection of the push-pull cable to the gearbox side

Position the gearbox lever in neutral (the lever must be vertical).

1. Adjust the fixing of the push-pull cable in such a way that when the lever is in vertical position, the cable must be at its half stroke
2. Connect the push-pull cable to the throttle lever using the fork.

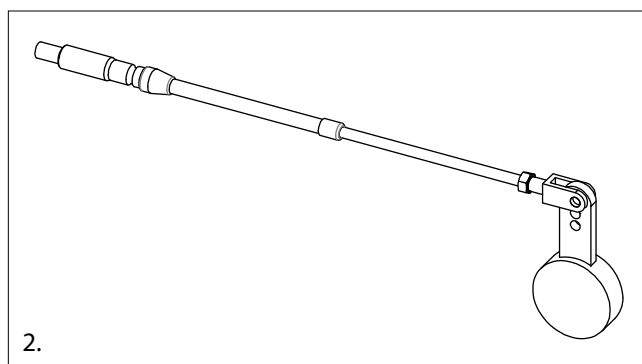
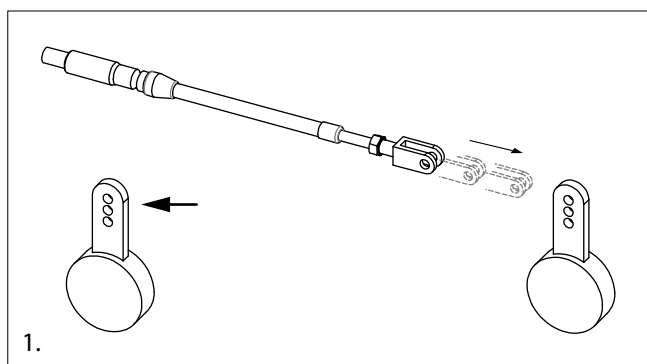

#### 10.3.2 Connection of the push-pull cable to the actuator

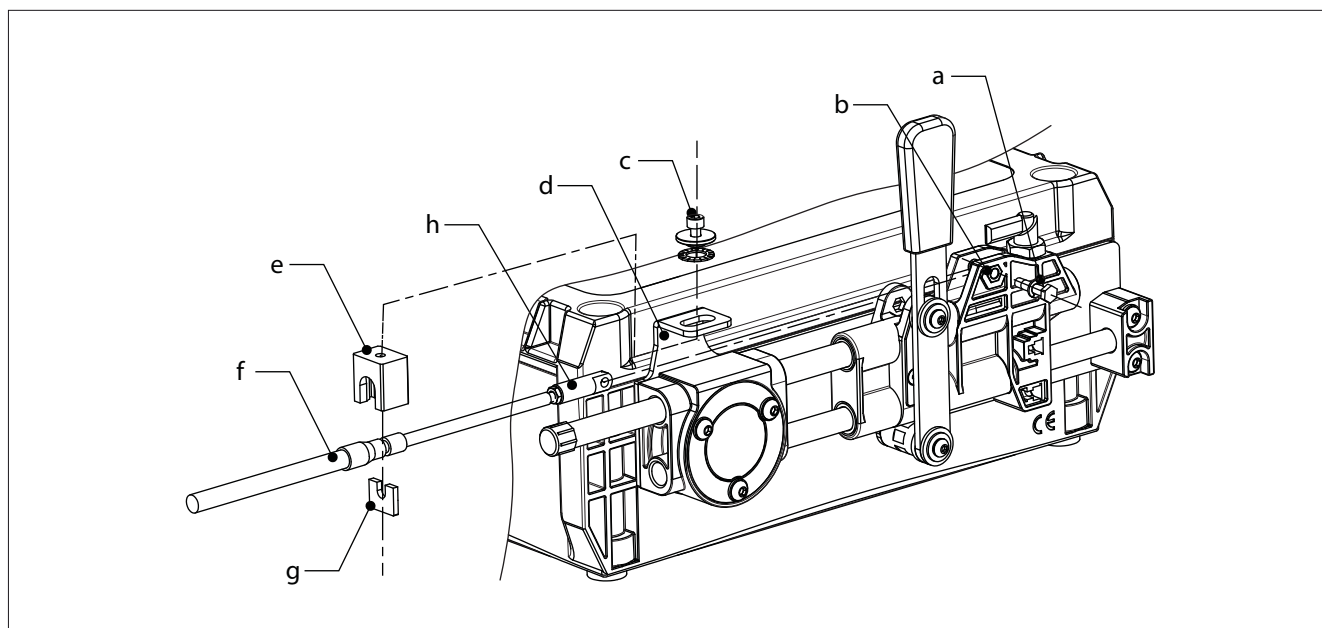

Elements to be used for the connection

- a Screw + elastic washer to connect the eyelet
- b Hole where to fix the eyelet
- c Fixing screw (screw and washers)
- d Bracket slot

- e Black aluminium cube
- f Push-pull cable
- g Blade
- h Eyelet



Follow the steps from 1 to 8 as reported here below:

1. Verify that the actuator's gear lever is in neutral position, as depicted in the picture here below (1). The lever should be vertical, otherwise enter into the JOG MODE and move the actuator's lever to central position. For this operation follow steps from 1 to 7 of section 12.1. The neutral position is parameter "0F".
2. Verify that the position of the gearbox lever is in neutral on the gearbox side as described previously. The push-pull cable must be at its half stroke also on the actuator's side. Then screw the eyelet (h) onto the cable's rod (2).

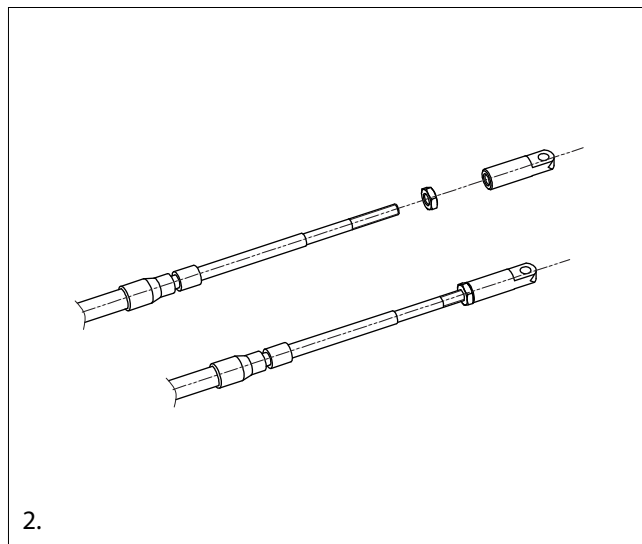
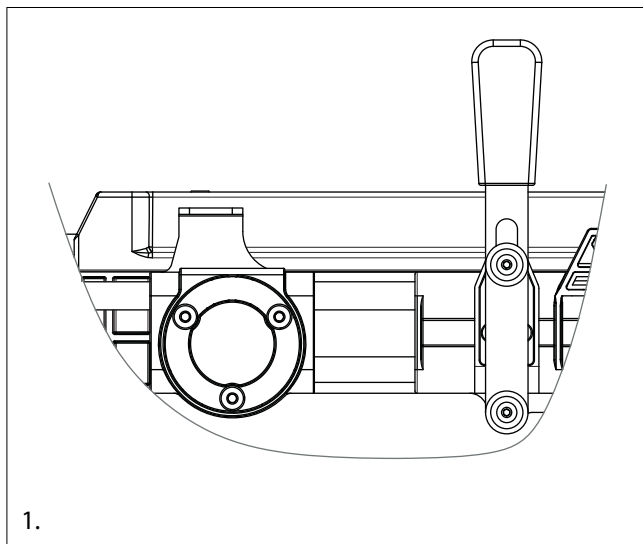

3. Position the push-pull cable with the hole on the eyelet (H1) aligned with the hole of the plastic slider (H2). Insert the screw (+ elastic washer) and fasten it.

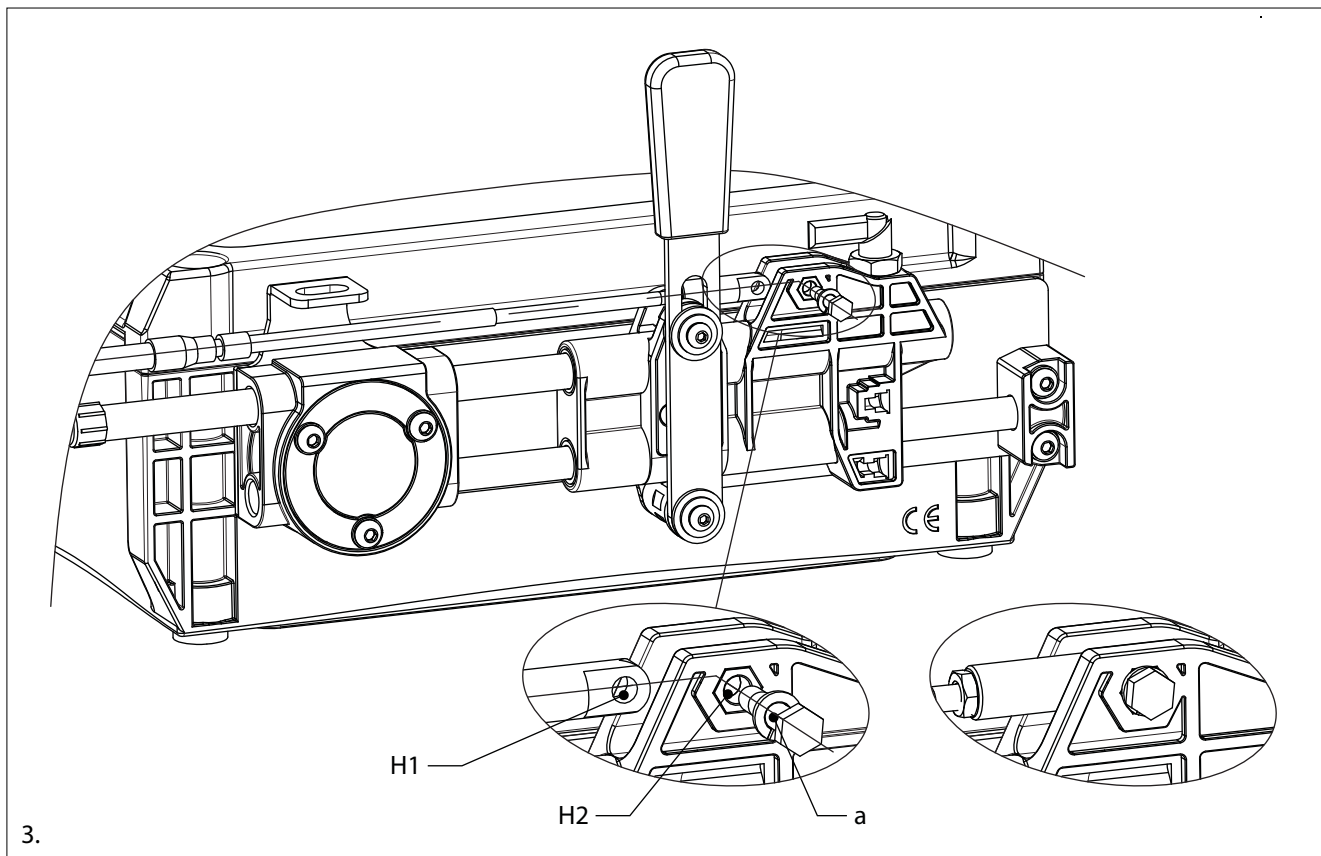

4. Connect the blade (g) and the black aluminium cube (e) onto the push-pull cable's hub.

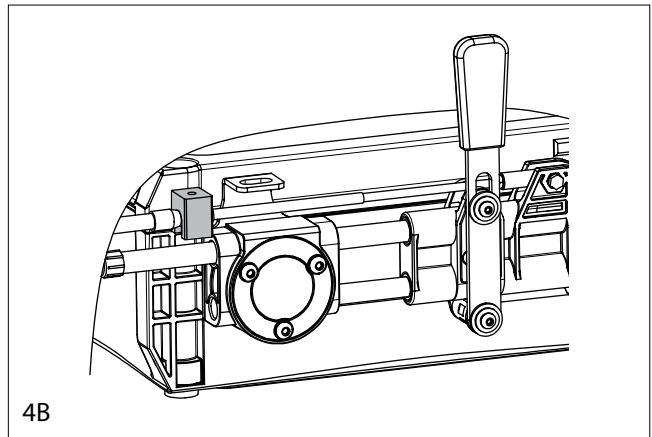
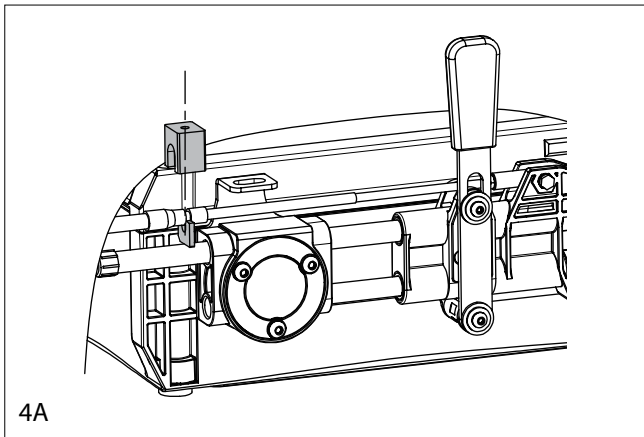

5. Then insert the push-pull cable into the bracket slot (d), picture 5. Verify that the fixing element is centred into the bracket slot.

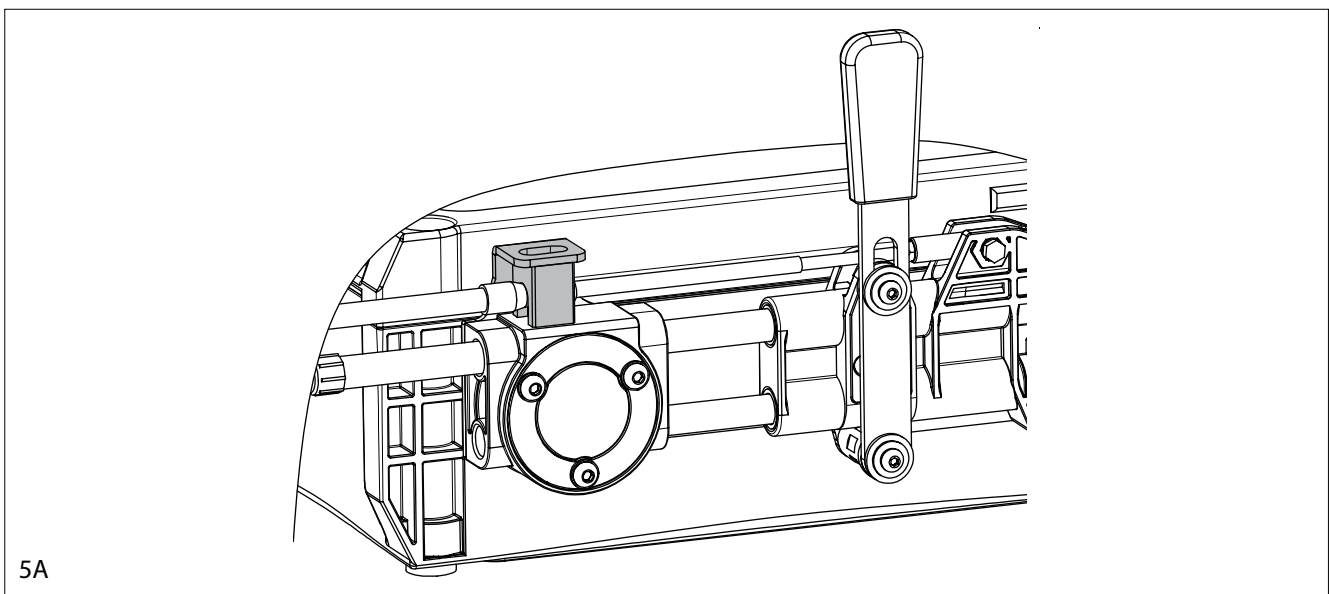

6. Fix the black aluminium cube (e) against the bracket (d) using the fixing screw (c).

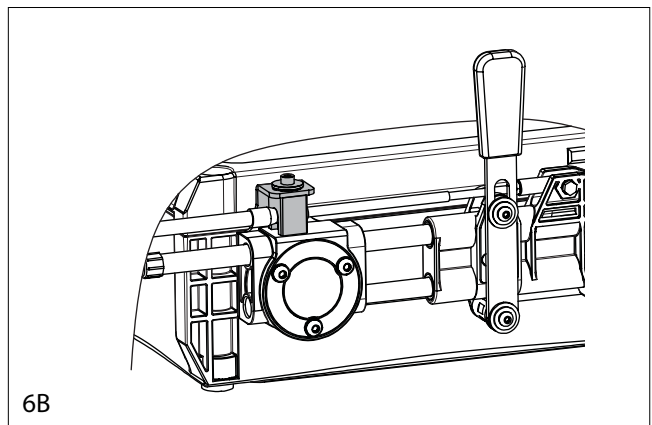
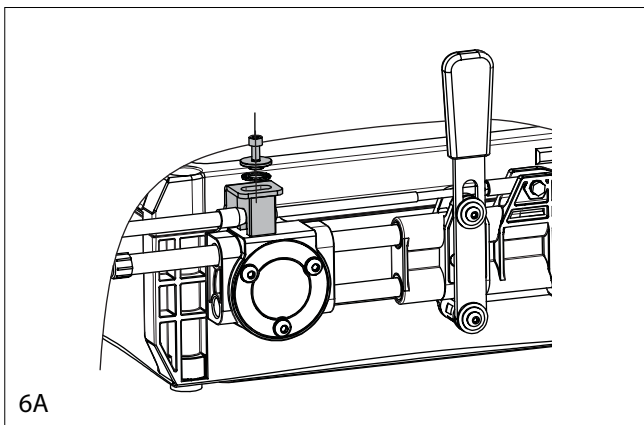

7. If the fixing position is not correct, tune the push-pull cable in such a way that when the gearbox's lever is in neutral, the push-pull cable is at its half stroke and the fixing screw is aligned with the notch.

8. Verify and eventually tune again the neutral position, set reverse (0L) and forward (0H) positions. For these operations look at section 12.1

# 11 Programming of the strokes on actuator with mechanical interface to engine and gearbox

**System's components involved:** push-pull cables, actuator

In this chapter it will be presented how to program the actuator, in order to obtain the correct strokes for engine and gearbox. The actuator looks according to the picture here below.

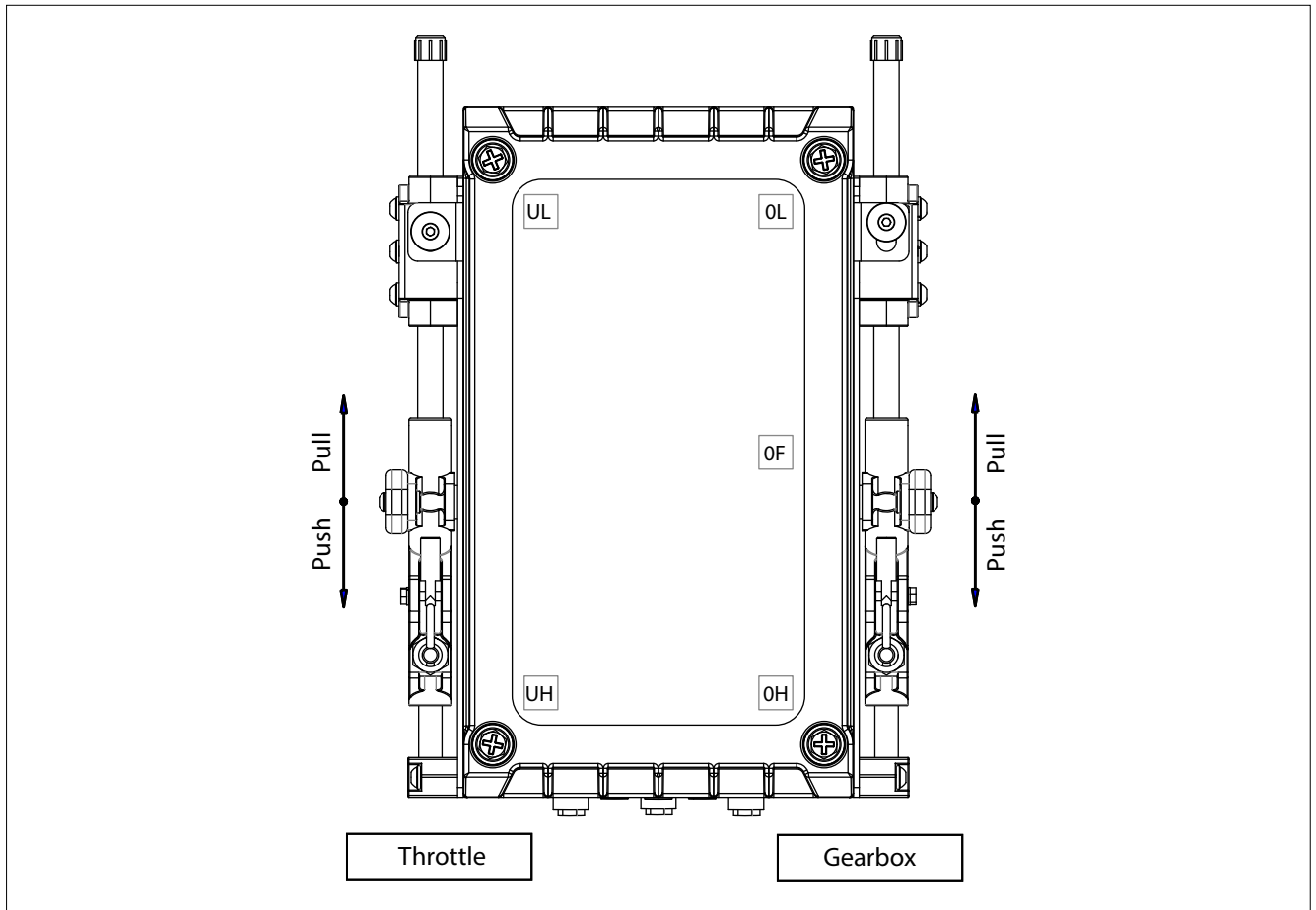

You must program 5 positions and therefore 5 parameters: 2 for the throttle and 3 for the gearbox. Gearbox and throttle positions have to be set according to the parameters of the here below table.

Parameters to set	Value on display	Function
Throttle	UL	Minimum speed position
	UH	Maximum speed position
Gearbox	OL	Gearbox Reverse
	OF	Gearbox Neutral
	OH	Gearbox Forward

Actuators are delivered from factory with:

- No throttle stroke,
- Forward, Reverse and Neutral positions coincident with the Neutral position

In order to start-up correctly the system you must do the correct setting the cable strokes.

## 11.1 Programming of the push-pull cable strokes

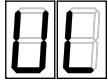
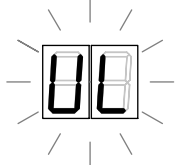
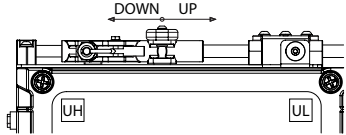
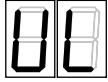
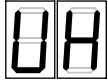
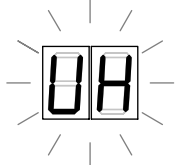
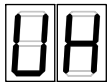
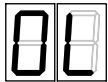
1	Switch-off the power supply, either from the mains or unplug and plug-in again the supply connector	
2	Open the Actuator box and identify the programming keypad (3 push buttons) and the display (2 digits)	
3	Press at the same time key "UP" and "DOWN" and, keeping pressed both keys "UP" and "DOWN", turn on the actuator's voltage supply	
4	On the 2-digit display shows up, with a steady light "UL", which corresponds to parameter Minimum Throttle. If you don't need to modify the minimum stroke, jump to step 8 of this procedure	
5	Press the "Enter" push button and the display will start flashing	
6	When the display is flashing you have entered into the jog mode and if you press either the "Up" or the "Down" push button, the left push-pull cable will move according to the picture here beside. Press "Up" or "Down" to adjust the position of Minimum Throttle	
7	To store the position of Minimum Throttle, press "Enter" again. When the display stops flashing it means that you have stored the position	
8	Press the "Down" push button and the display will move to "UH" (parameter of Maximum Throttle)	
9	Press the "Enter" push button and the display will start flashing. Press "Up" until the cable reaches the position of Maximum Throttle	
10	To store the position of Maximum Throttle, press "Enter" again. When the display stops flashing it means that you have stored the position	
11	Press the "Down" push button and the display will move to "0L" (parameter of Gearbox Reverse)	

12	Press the "Enter" push button and the display will start to flash. Press "Up" until the cable reaches the position of Gearbox Reverse	
13	To store the position of Gearbox Reverse, press "Enter" again. When the display stops flashing it means that you have stored the position	
14	Press the "Down" push button and the display will move to "0F" parameter of Gearbox Neutral)	
15	Press the "Enter" push button and the display will start flashing. Press "Up" until the cable reaches the position of Gearbox Neutral	
16	To store the position of Gearbox Neutral, press "Enter" again. When the display stops flashing it means that you have stored the position	
17	Press the "Down" push button and the display will move to "0H" parameter of Gearbox Forward)	
18	Press the "Enter" push button and the display will start flashing. Press "Up" until the cable reaches the position of Gearbox Forward	
19	To store the position of Gearbox Forward, press "Enter" again. When the display stops flashing it means that you have stored the position	

**Important:**

- a not precise setting of the strokes may generate malfunctioning of the gearbox (delays in clutch-in and clutch-out) or an excessive current absorption on the actuator.
- in case of stern drive and outboard engines, if the engine isn't running, it isn't possible to set the strokes, because the clutch-in operation becomes very hard. In this is the case, actuate the rotation of the propeller manually, this will make easier the clutch-in of the gearbox.

## 11.2 Sea trials

Now your programming is finished!

In order to verify the settings you need to activate your electronic control system.

Switch-off the power supply and then switch on again.

If all the settings have been done correctly, the command station will look as follow:

Command station series 4500

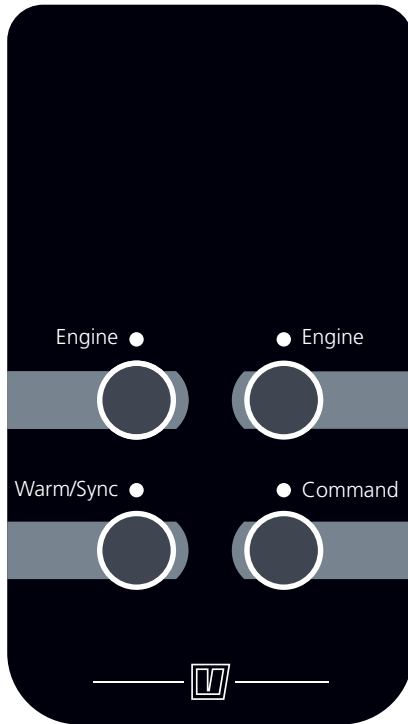

To learn about how to command the boat go to chapter 3 (Pilot Instructions).

You must test now the correct functioning of the gearbox and the throttle in relation to the command lever. After having set the stroke positions, it might happen that there is not the right correspondence between the direction of the lever and the movement executed by the actuator (e.g.: you move the lever forward and the gearbox cable is pushing instead of pulling).

Changing the value of parameter A0 you can modify the correlation between the direction on the lever and the direction on the actuator. The table here below defines the directions of throttle and gearbox in relation to the 4 possible values of parameter A0, **with the assumption to move the command station lever in forward direction** (gearbox forward and engine accelerated).

Value A0	Throttle	Gearbox
1	Push (direction UL)	Pull (direction 0H)
2	Push (direction UL)	Push (direction 0L)
3	Pull (direction UH)	Push (direction 0L)
4	Pull (direction UH)	Pull (direction 0H)

Factory setting A0 = 4

The following examples show how to operate in case there is not the exact correspondence between the command lever and the actuator.

<b>System with mechanical throttle and mechanical gearbox</b>	
	<p><b>Problem</b></p> <p>The gearbox push-pull cable positions are inverted (forward and backward positions are inverted) while the throttle push-pull cable works correctly</p> <p><b>Solution</b></p> <p>Set A0=3</p>
	<p>The gearbox is working correctly while the throttle push-pull cable positions are inverted (min and max throttle positions are inverted)</p> <p>Set A0=1</p>
	<p>Both gear or throttle push-pull cables positions are inverted</p> <p>Set A0=2</p>

### 11.3 Specific parameters

Display code	Description	Values	Factory value	Value shown on display (factory value)	Note
A0	Push-pull cable movement direction	1 .. 4	4	04	
dI	Delay before disengaging the gearbox	0 .. 9.9 s	0.0 s	00	
dA	Delay on the throttle	0 .. 9.9 s	0.0 s	00	
PP	Proportional coefficient	0 .. 99	40	40	These parameters must not be modified
PI	Integral coefficient	0 .. 99	0	00	
CC	To be used for the check-up of the internal CANBus communication				

## 12 Programming of actuators for installations with electronic engine and mechanical gearbox

System's components involved: push-pull cables, actuator

In this chapter it will be presented how to program the actuator, in order to obtain the correct strokes of gearboxes. Depending if the boat is with 1 or 2 propulsion systems, the actuator looks according one of the pictures here below:

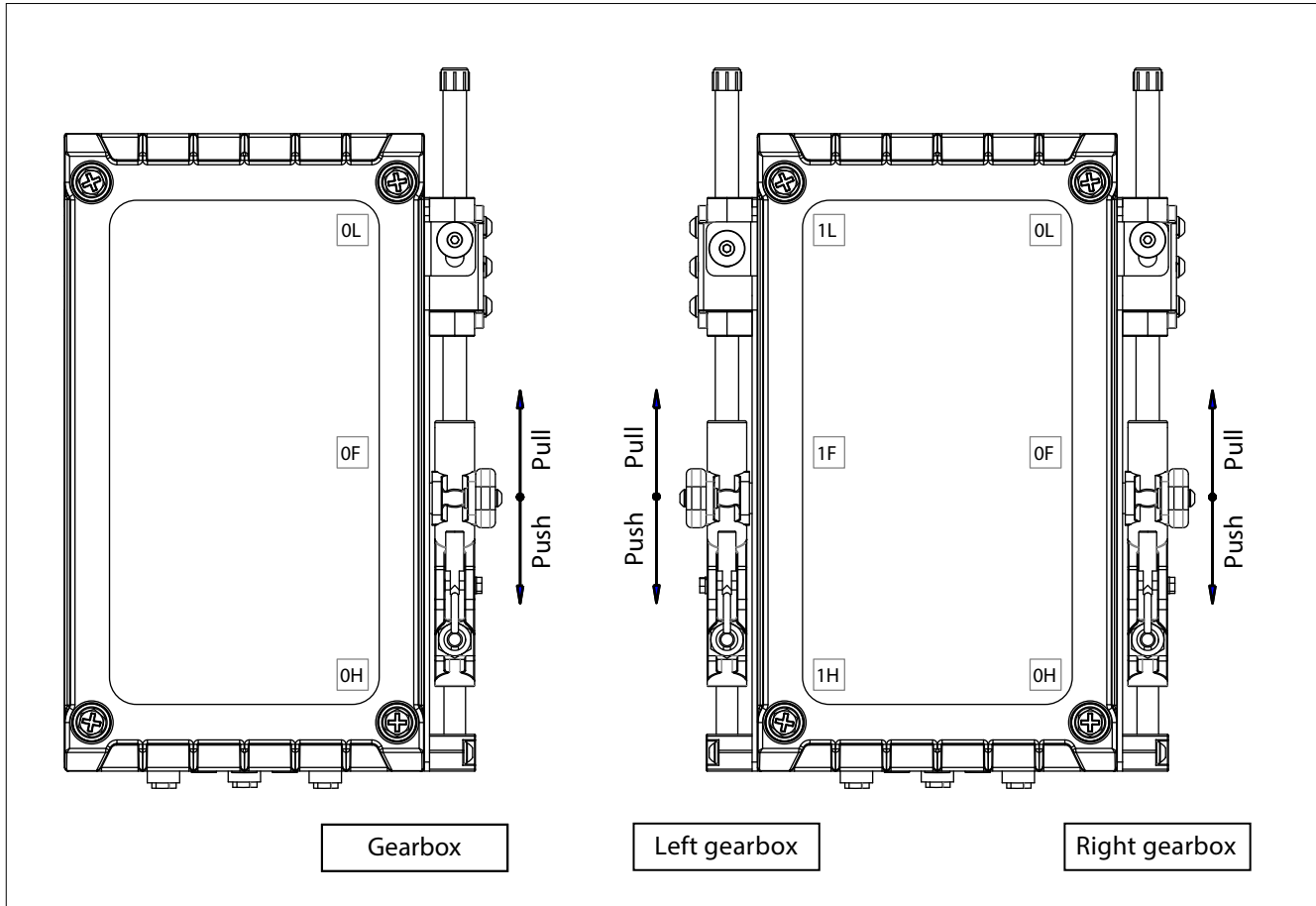





You must program either 3 or 6 positions and consequently 3 or 6 parameters: 3 for per each gearbox, according to the parameters of the above table.

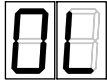
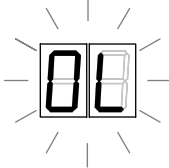
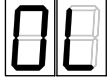

Parameter	Value on display	Function
Gearbox 1 (right)	0L	Gearbox Reverse
	0F	Gearbox Neutral
	0H	Gearbox Forward
Gearbox 2 (left)	1L	Gearbox Reverse
	1F	Gearbox Neutral
	1H	Gearbox Forward

Actuators are delivered from factory with Forward, Reverse and Neutral positions coincident in the Neutral position. Therefore the installer must do the correct setting the stroke, in order to start-up correctly the system.

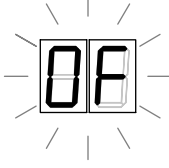

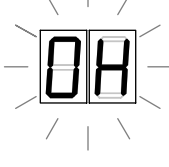
## 12.1 Programming of the gearbox strokes

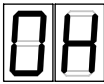
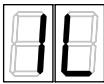
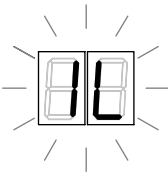
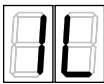
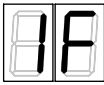
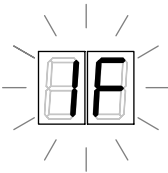
1	Switch-off the power supply, either from the mains or unplug and plug-in again the supply connector	
2	Open the Actuator box and identify the programming keypad (3 push buttons) and the display (2 digits)	
		
3	Press at the same time key "UP" and "DOWN" and, keeping pressed both keys "UP" and "DOWN", turn on the actuator's voltage supply	
4	On the 2-digit display shows up, with a steady light "0L", which corresponds to parameter (right) Gearbox Reverse	
5	Press the "Enter" push button and the display will start flashing. Press "Up" until the cable reaches the position of Gearbox Reverse	
6	To store the position of Gearbox Reverse, press "Enter" again. When the display stops flashing it means that you have stored the position	
7	Press the "Down" push button and the display will move to "0F" (parameter of Gearbox Neutral)	
8	Press the "Enter" push button and the display will start flashing. Press "Up" until the cable reaches the position of Gearbox Neutral	
9	To store the position of Gearbox Neutral, press "Enter" again. When the display stops flashing it means that you have stored the position	
10	Press the "Down" push button and the display will move to "0H" (parameter of Gearbox Forward)	
11	Press the "Enter" push button and the display will start flashing. Press "Up" until the cable reaches the position of Gearbox Forward	

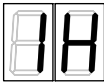
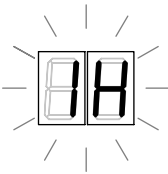
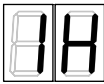
12	To store the position of Gearbox Forward, press "Enter" again. When the display stops flashing it means that you have stored the position	
13	Press the "Down" push button and the display will move to "1L" (parameter of left Gearbox Reverse)	
14	Press the "Enter" push button and the display will start flashing. Press "Up" until the cable reaches the position of Gearbox Reverse	
15	To store the position of Gearbox Reverse, press "Enter" again. When the display stops flashing it means that you have stored the position	
16	Press the "Down" push button and the display will move to "1F" (parameter of Gearbox Neutral)	
17	Press the "Enter" push button and the display will start flashing. Press "Up" until the cable reaches the position of Gearbox Neutral	
18	To store the position of Gearbox Neutral, press "Enter" again. When the display stops flashing it means that you have stored the position	
19	Press the "Down" push button and the display will move to "1H" (parameter of Gearbox Forward)	
20	Press the "Enter" push button and the display will start flashing. Press "Up" until the cable reaches the position of Gearbox Forward	
21	To store the position of Gearbox Forward, press "Enter" again. When the display stops flashing it means that you have stored the position	

**Important:**

- a not precise setting of the strokes may generate malfunctioning of the gearbox (delays in clutch-in, clutch-out) or an excessive current absorption on the actuator.
- in case of stern drive and outboard engines, if the engine isn't running, it isn't possible to set the strokes, because the clutch-in operation becomes very hard. In this is the case, actuate the rotation of the propeller manually, this will make easier the clutch-in of the gearbox.

## 12.2 Sea trials

Now your programming is finished!

In order to verify the settings you need to activate your electronic control system.

Switch-off the power supply and then switch on again.

If all the settings have been done correctly, the command station will look as follow:

Command station series 4500

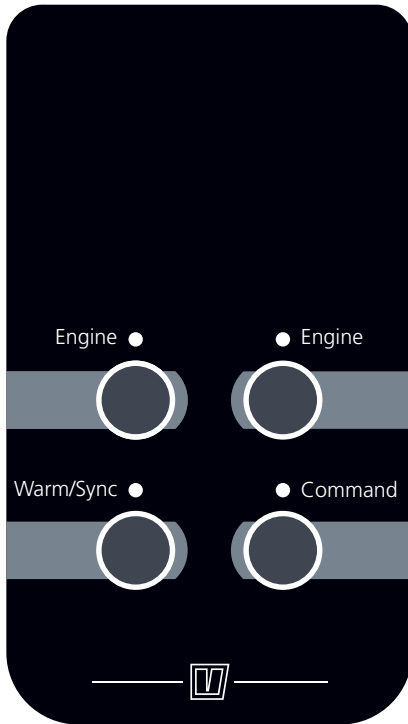

To learn about how to command the boat go to chapter 3 (Pilot Instructions).

You must test now the correct functioning of the gearbox in relation to the command lever. After having set the stroke positions, it might happen that there is not the right correspondence between the direction of the lever and the movement executed by the actuator (e.g.: you move the lever forward and the gearbox cable is pushing instead of pulling).

Changing the value of parameter A0 you can modify the correlation between the direction on the lever and the direction on the actuator. The table here below defines the directions of throttle and gearbox in relation to the 4 possible values of parameter A0, **with the assumption to move the command station lever in forward direction** (gearbox forward and engine accelerated). With the assumption that you have done all the stroke setting with A0 = 4 (factory setting), modify the correlation between lever and actuator as described in the schemes of the next page.

**System with one electronic motor and one gearbox mechanically driven**

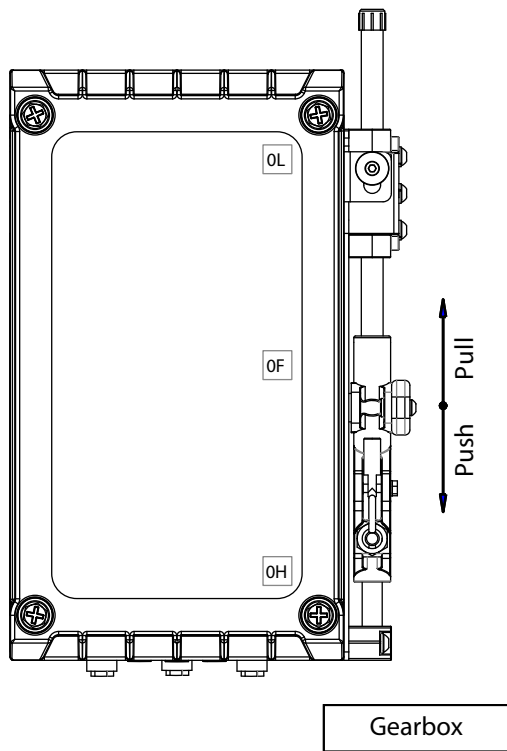

**Problem**

The gearbox push-pull cable positions are inverted

**Solution**

Set A0=3

**System with two electronic motors and two gearboxes mechanically driven**

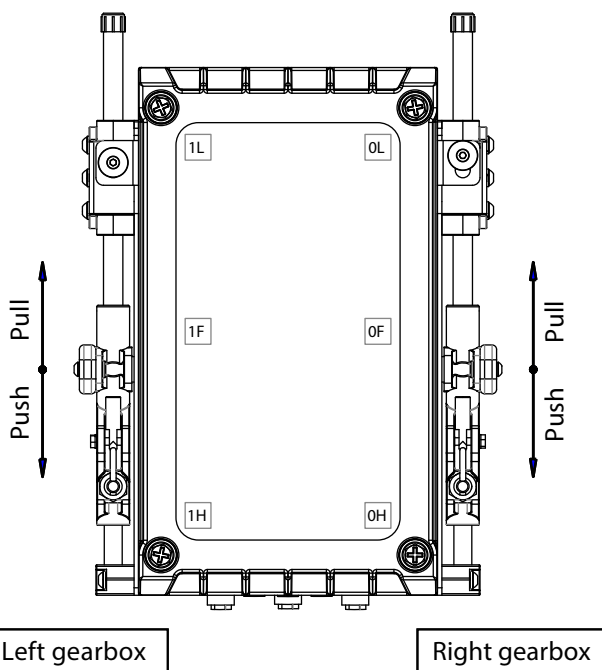

**Problem**

Positions of the right gearbox are inverted while the positions of the left gearbox are correct

**Solution**

Set A0=3

Positions of the left gearbox are inverted while the positions of the right gearbox are correct

Set A0=2

Positions of both gearboxes are inverted

Set A0=1

## 12.3 Specific parameters

Display code	Description	Values	Factory value	Value shown on display (factory value)	Note
A0	Push-pull cable movement direction	1 .. 4	4	04	
dI	Delay before disengaging the gearbox	0 .. 9,9 s	0,0 s	00	
dA	Delay on the throttle	0 .. 9,9 s	0,0 s	00	
PP	Proportional coefficient	0 .. 99	40	40	These parameters must not be changed
PI	Integral coefficient	0 .. 99	0	00	
CP	CANBus protocol	1-99	0	00	See 15.2.2.
L1	These parameters are present only in systems with electronic engine (ECU) and/or electrical engine inverter driven. Parameters to define the voltage output interface will be detailed at section 12.3.2.				
H1					
L2					
H2					
L3					
H3					
L4					
H4					
CC	To be used for the check-up of the internal CANBus communication				

### 12.3.1 Parameters to configure the voltage output signal for electronic engines

For installations with electronic engines or hybrid propulsion systems (engine driven by a frequency converter), it is necessary to set the minimum and maximum voltage output. Voltage signal profile is defined through parameters L\*, and H\*, where "\*" means 1,2,3,4.

**Important:** the graphic on the right represents the voltage profile defined by parameters L, H. Changes of factory values could cause a system malfunctioning. Before making any changes, contact our technicians.

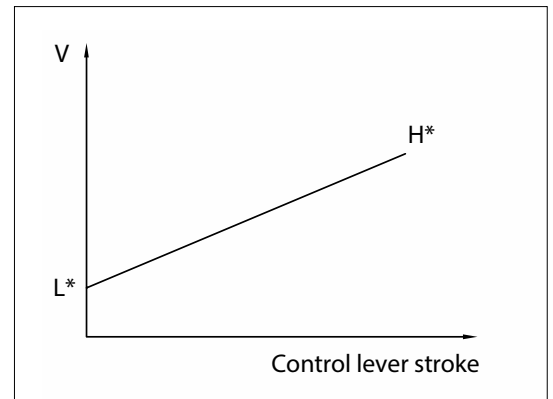

### 12.3.2 Parameters to configure the voltage output signals

Parameters		FNM Vetus	Nanni Diesel (Toyota)		Hyundai	Steyr		Mercury		John Deere	Cummins	FPT	Scania
			T4.270	Others		IVS	2 Ch	Others	QSD 2.8 VM				
L1	Motor DX	9	10	13	8	5	7	8	8	6	8	5	5
H1		43	38	40	42	43	37	48	44	45	42	45	28
P1		NA	NA	NA	NA	10	NA	NA	NA	NA	NA	NA	NA
L2		5	0 *	0 *	4	0	43	4	4	NA	NA	NA	NA
H2		21	50 *	50 *	21	50	13	24	22	NA	NA	NA	NA
L3	Motor SX	9	10	13	8	5	7	8	8	6	8	5	5
H3		43	38	40	42	43	37	48	44	45	42	45	28
P3		NA	NA	NA	NA	10	NA	NA	NA	NA	NA	NA	NA
L4		5	0 *	0 *	4	0	43	4	4	NA	NA	NA	NA
H4		21	50 *	50 *	21	50	13	24	22	NA	NA	NA	NA

\* For Nanni Diesel / Toyota, L2, H2, L4, H4 must be programmed only if the diesel motor is combined with the electrical motor. For further information see section 19.4, Programming of actuators with Hybrid engine option.

# 13 Programming of actuators for mechanical engines and electronic gearbox

## 13.1 Mounting of the engine the push-pull cable and programming of throttle mechanical strokes

For the connection of the push-pull cables please refer to chapter 10. To set strokes refer to chapter 11. In case of actuators for 2 mechanical accelerators and 2 electronic gearboxes, the following parameters must be programmed.

Parameter	Value on display
Left throttle	UL
	UH
Right throttle	PL
	PH

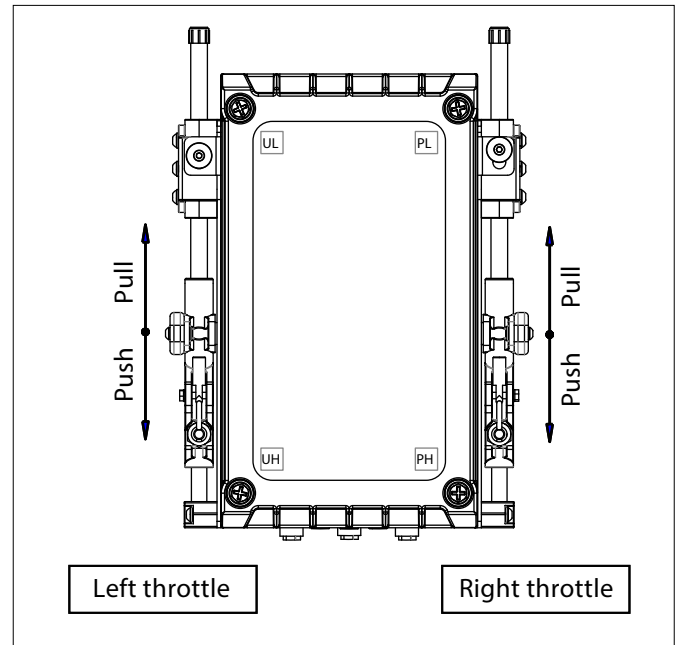

## 13.2 Programming of the push-pull cable strokes

With this kind of actuator you must program 2 positions for each engine (minimum throttle and maximum throttle). For the general programming instructions please refer to chapters 10 and 11.

## 13.3 Electrical cabling of the gearbox

For each gearbox are available 2 output relays. For proper wiring please refer to sections 5.4.2, 5.4.3, 8.2.5 and 8.2.6. of this manual.

## 13.4 Specific parameters

Installations with electronic gearbox might require a delay time when you pass the lever directly from reverse to forward or from forward to reverse. Factory setting is 0,5 seconds.

Display code	Description	Values	Factory value	Value shown on display (factory value)
dI	Delay in switching off the gearbox	0 .. 9,9 s	0,0 s	00
dA	Delay in start of throttle	0 .. 9,9 s	0,0 s	00
dF	Delay in neutral: it occurs any time you move directly from forward to reverse or from reverse to forward. This delay does not occur when from neutral you move to forward or reverse.	0 .. 9,9 s	0,5 s	05

# 14 Programming of actuators with electronic engine and electronic gearbox

## 14.1 Electrical wiring

For electrical wiring please refer to chapter 8.

## 14.2 Specific parameters

Installations with electronic gearbox might require a delay time when you pass the lever directly from reverse to forward or from forward to reverse. Factory setting is 0,5 seconds.

Display code	Description	Values	Factory value	Value shown on display (factory value)	Note
dI	Delay in switching off the gearbox	0 .. 9,9 s	0,0 s	00	
dA	Delay in start of throttle	0 .. 9,9 s	0,0 s	00	
dF	Delay in neutral; it occurs any time you move directly from forward to reverse or from reverse to forward. This delay does not occur when from neutral you move to forward or reverse.	0 .. 9,9 s	0,5 s	05	
L1	These parameters are present only in system with electronic engine with ECU and/or electric engine inverter driven. Parameters for the voltage outputs are described at section 12.3.2.				
H1					
C1					
L2					
H2					
C2					
L3					
H3					
C3					
L4					
H4					
C4					
CC		To be used for the check-up of the internal CANBus communication			



# 15 System configuration in case of options

## 15.1 Commissioning of actuators for installations with Trim or Flap command option

Trim or flap options don't require any programming on the actuator.

Trim and flap cables are reported from section 6.4 to section 6.5 included.

Sections 5.3.2 and 5.3.3 depict the pin-out of the electronic PCBs which perform the trim/flap commands. Electrical installation schemes are at sections 8.2.7 and 8.2.8.

## 15.2 Commissioning of actuators for installations with Trolling option

The command station must be configured by setting dip-switch 2 to ON (see section 4.5 of this manual). The actuator is specific for this type of system. For its programming, refer to the document "Trolling\_Flap option for lever EC3 & EC4".

## 15.3 Commissioning of the actuators with Neutral Relay option

The mechanical actuator can provide a no contact signal when the gearbox is in neutral. This signal, if properly used in the engine starter safety chain, allows the start of the propulsion engine only in case the gearbox is in neutral position.

The neutral signal is given through a two pole wire, as depicted here below. The neutral relay is normally open and it closes only in case the gearbox is in neutral and the actuator is properly supplied (if the actuator doesn't receive the power supply the relay is switched off and its contact is open).

The block diagram here below shows the safety chain:

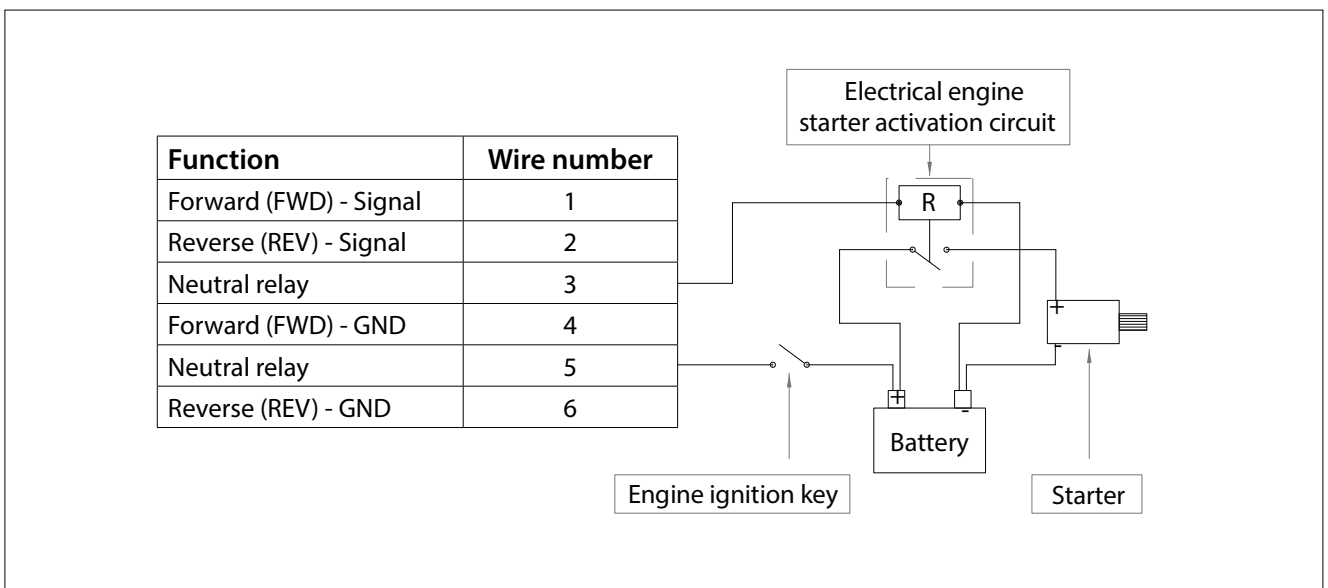

Specific neutral cable is described at section 6.3

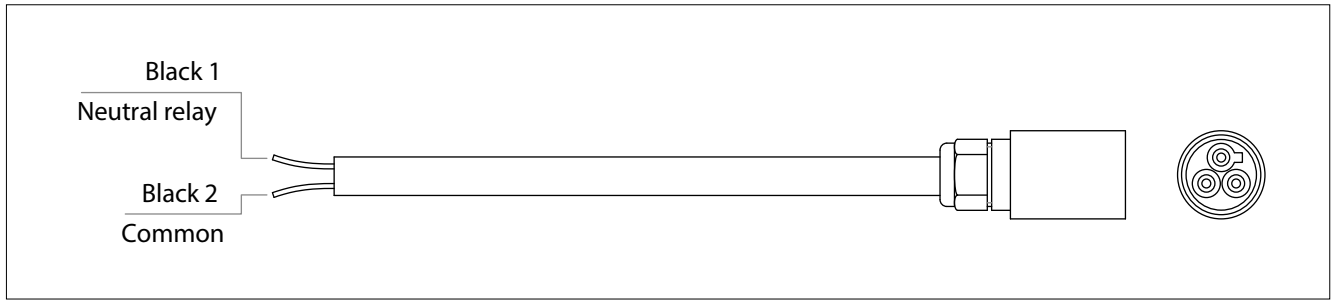

Length	Code
L=3 m	EC3T2

**To be noticed:**

- the cable has 3 wires: black 1, black 2 and yellow/green. For this application do not use the yellow/green wire.
- maximum current which can be commutated by the neutral relay is 10 A.
- in case the actuator is not supplied, you cannot start the engine unless you provide a by-pass electrical circuit for emergency situations.
- actuator with mechanical interface is just giving the information that itself is in neutral position. The neutral position on the gearbox is to be considered valid only if the push-pull cable is mounted correctly.

Neutral relay option cables are depicted in sections 6.3.3 and 6.3.4. Installation schemes are at sections 8.2.5 and 8.2.6.

## 16 Trouble shooting

### 16.1 What to do in case of system failure

Here below are described standard procedures to follow in case of faults. In case of vessel with 2 engines or of vessel with two or more command stations, the redundancy of the system can overcome the situation of a first failure and the electronic control system could continue to operate, but it is advisable to recover the boat and immediately find and solve the problem.

#### 16.1.1 Behaviour of the system in case of unforeseen shutdown

In case the engine switches off during navigation, the normal procedure requires to turn off the ignition key and then to turn it on again. At power-up, independently on the position of the command station, the actuator behaves as follows:

- Gearbox is moved to a the safety position (neutral)
- Engine throttle is moved to minimum

The command station that had the control of the vessel, has now lost the command. To take the command again, you must start again the following procedure:

- move the lever to neutral
- press "Command" and then "Warm-up".

This procedure is described in section 3 of this manual.

#### 16.1.2 Emergency lever and how to overcome faults during navigation in case of system with mechanical interface

In case of system's fault due to:

- missing power supply
- data transmission cables broken
- broken push-pull cables

the electronic system can be switched off quickly and the engines and gearboxes can be operated directly by the mechanical emergency levers. If you have the connector panel in front of you, the right emergency lever is for gearbox, the left emergency lever is for engine.

Emergency levers are fitted on the control box. During the normal functioning, the indexing plunger device "A" is positioned as shown in the picture on the left. In emergency situation, to unlock the mechanism it is enough to rotate of 180° the plunger "A" from its working position. After this operation, the mechanism (and the related push-pull cable) can be operated manually using lever (B).

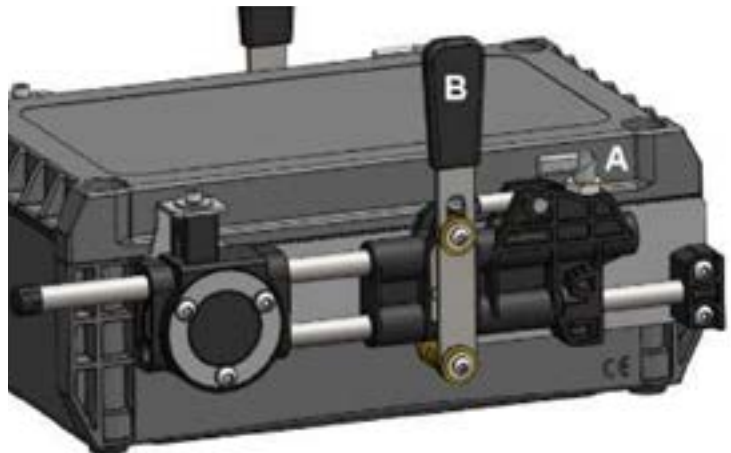

In order to engage again the system you must:

1. Rotate or assure that the mechanical indexing plunger device "A" is in lock position (like in the picture)
2. Move the emergency lever "B" towards the centre of stroke and move it back and forward until you hear a "click".
3. Verify that after the "click" the lever is engaged (you cannot move it freely by hand). In case the emergency lever is still free, repeat operations from point 1 to 3.

### 16.1.3 Self-protection in case of overload or breakage of the push-pull cables

The 2 digit display on the actuator is a helpful instrument during trouble shooting. The actuator has a built-in control that generates an alarm signal in case the push-pull cable becomes “too hard” or in case the cable’s stroke is not set correctly (beyond the maximum stroke allowed by the actuator).

If one of the above mentioned cases occurs:

- the systems stops (no movements on the push-pull cables)
- on the display of the actuator appears an “E” or a “P” on the side of the overloaded cable
- all the LEDs of the command stations start to blink.

An “E” or “P” will be shown on the side of the actuator with the cable overload error or the cable positioning error

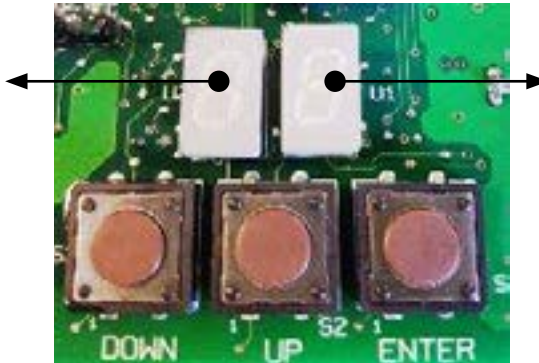

An “E” or “P” will be shown on the side of the actuator with the cable overload error or the cable positioning error

“E” stands for overload failure.

“P” stands for position failure (missed position target).

In case one of the two alarms occurs, turn off the system and verify the causes that might have generated the alarm:

- errors in stroke setting, bending radius of the push-pull cables too small or push-pull cable “squeezes”
- performance of the push-pull cable too low or control cable degenerated over time: if push pull cables are not performing correctly, they must be replaced.

Restart the electronic control system only if you have removed the causes of the not correct functioning.

## 16.2 Analysis of the electronic system behaviour

It follows a list of behaviours, error messages and their possible remedies.

Symptom	What to check	What to do	Where to look on the product manual
After power up, there is no light on command station or on actuators	Power supply is missing, check the causes:		
	Circuit breaker not correctly connected	Check and eventually replace the circuit breaker	
	Electrical cables from the battery to the actuator	Check and fix supply cables	
	The fuse on the actuator is blown-up	Verify that the power supply connector of the actuator is wired with the correct polarity.	Chapters 5 and 8
The 4 LEDS blink twice at power on but then the green LEDS are off and the command station doesn't take the command	Check that end of line resistance terminations have been correctly activated both on actuators and on command stations	Program dip-switches according to your installation scheme.	Section 4.4. and chapters 7 and 8
LEDs on command station are never enlightened while the display on the actuator is enlightene	CANBus data transmission cable doesn't transmit power from actuator to command station	Check if the CANBus data transmission cable is correctly connected on the command station (connector nut requires 5.5 turns to be fully seated). If power supply is still missing, replace the CANBus data transmission cable	Chapter 6
Without moving any lever of the command station, the actuator generates changes of speed or unpredictable engagement of the gear	2 command stations have the same CAN address	Re-assign the CAN addresses on the command station, set correctly the dipswitches positioned below the command station	Section 4.4. and chapters 7 and 8
Only one lever commands both the actuators, while the second lever is not active	Command station is in Synchro mode	De-activate the Synchro mode with the push-buttons on the command station	Chapter 3
	The two actuators might have the same CAN address and receive the command from the same lever	Program dip-switch JP14 according to the following: JP14 = OFF for the left actuator JP14 = ON for the right actuator Verify also that JP19 is programmed according to the installation scheme that you have chosen (see from section 7.1 to section 7.5)	Section 4.4. and chapters 7 and 8

Symptom	What to check	What to do	Where to look on the product manual
LEDs have faint light or the reaction time to the command is very slow	Check battery voltage		
The motor doesn't reach the correct minimum or maximum speed (installations with mechanical actuators)	Check if the stroke of the push-pull cable is correct, both on the engine and on the actuator	Tune the push-pull cable on the engine and make a precise setting of the stroke on the actuator	Chapter 10
The setting of the strokes has been done successfully (chapter 13) but the actuator doesn't respond to the commands during normal operation	Verify that parameter PP = 40	Set PP = 40	Chapters 9 and section 11.3
The engine doesn't accelerate but it is possible to engage the gear (installations with mechanical actuators)	Check the stroke of the gearbox. If you set a stroke longer than necessary, the gear can be engaged, the actuator doesn't manage to reach the target position and therefore it doesn't activate the throttle	Reprogram the gearbox stroke	Chapter 11
With the control station lever at minimum, the engine is fully accelerated (installations with mechanical actuators)	There isn't the right correlation between the position of the lever of the command station and the movement generated by the actuator	Modify the setting of parameter A0	Schemes at sections 11.2 and 12.2
Lever is in forward or reverse position but the gear is not engaged (installations with pushpull cables)	Check the stroke of the push pull cable is correct, both on the gearbox and on the actuator	Tune again the push-pull cable both on the gearbox and on the actuator	Chapter 11
The lever of the command station is forward but it is activated the reverse gear instead of the forward gear (installations with mechanical actuators)	There isn't the right correlation between the position of the lever of the command station the movement generated by the actuator	Modify parameter A0	Sections 11.2 and 12.2

## 16.3 Diagnosis through the command station

LEDs of the command station produce flashes to show operating conditions, warning and failure conditions.

LED indications	When it happens	Meaning/problem	What to do
All LEDs are blinking with 1° flash long and 2° flash long	At power up	Command station configured for installations with 1 engine	If you need to reconfigure the command station, see section 4.3
All LEDs are blinking with 1° flash short and 2° flash long		Command station configured for installations with 2 engines and 1 actuator	
All LEDs are blinking with 1° flash short and 2° flash short		Command station configured for installations with 2 engines and 2 actuators	
The 2 green LEDs show a steady light when the levers are in neutral	After power up	Gearboxes are in neutral and the installation works correctly	
The 2 green LEDs are switched off, even if the levers are in neutral		Power supply is missing	Check if the display on the actuator is enlightened: <ul style="list-style-type: none"> <li>• if YES, verify the connection of CANBus data transmission cable;</li> <li>• if NO, check the electrical installation (chapter 8)</li> </ul>
One of the green LEDs is switched off, even if its corresponding lever is in neutral		The push-pull cable of the gearbox hasn't come to the assigned neutral position (actuators with mechanical interface)	Check and remove the obstacle which doesn't permit the actuator to go to neutral position (see chapters 10 and 11)
Green LED is blinking with duty cycle: 90% On and 10% Off		Command station is not configured correctly with respect to the type of installation; command station has been configured for installations with 1 actuator and it must be configured for installations with 2 actuators	Reconfigure command station as described at section 4.3
The green LED is slowly blinking (2 s period) with duty cycle: 50% On and 50% Off		There might be a problem on the position measuring device of the command station	Contact VETUS
LEDs are blinking according to the following combinations: <ul style="list-style-type: none"> <li>• Engine_left (green) + Wrm/ Sync(yellow)</li> <li>• Cmd (red) + Engine_right (green)</li> <li>• All the 4 LEDs together</li> </ul>		There is a failure on mechanical actuators, probably due to: <ul style="list-style-type: none"> <li>• an extra load on push-pull cables</li> <li>• wrong setting of the pushpull cable strokes</li> </ul>	Go to the actuator's display and check which is the cable that has generated the failure. On the display is shown the message "E" or "P" on the side where it has occurred the failure (see section 16.1.3), then: <ul style="list-style-type: none"> <li>• replace the defective push-pull cable</li> <li>• re-program the strokes of the push-pull cables (see chapters 10 and 11)</li> </ul>

# 17 Drilling mask for command stations

## 17.1 Command station series EC3

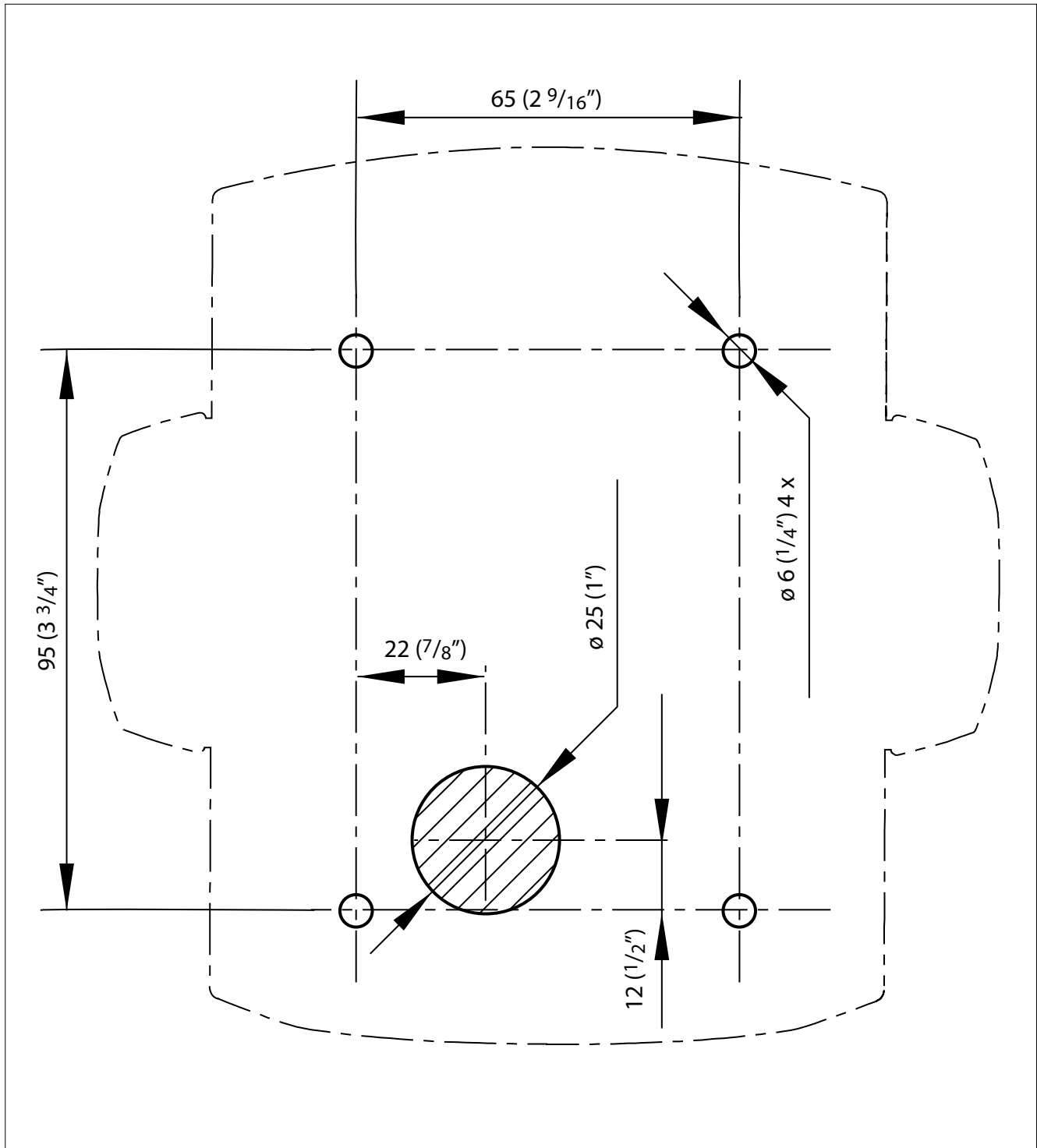



## 17.2 Command station series EC4

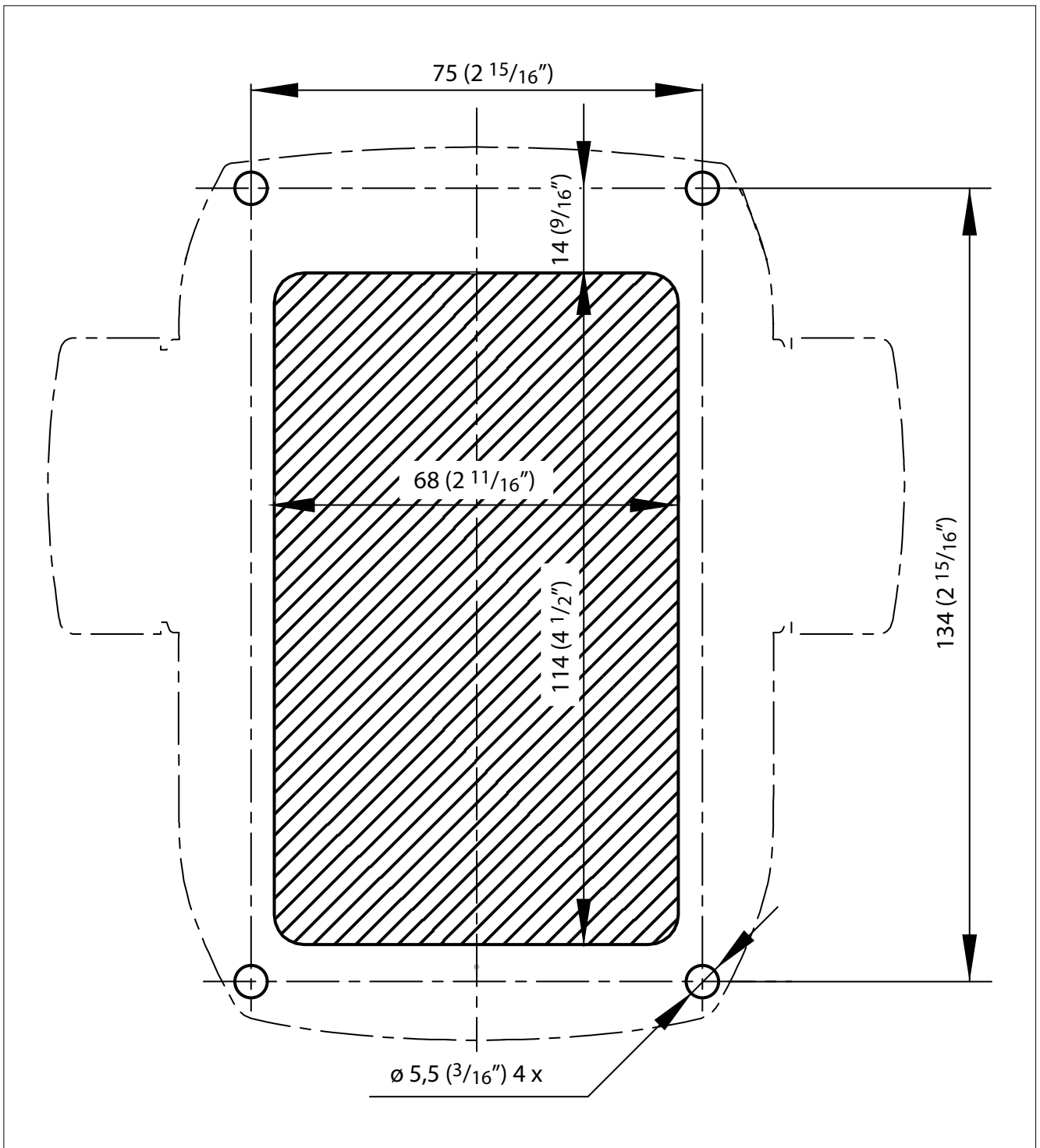

**Attention:** drawings here depicted are not corresponding to the object's real physical size

## 18 Drilling mask for actuator

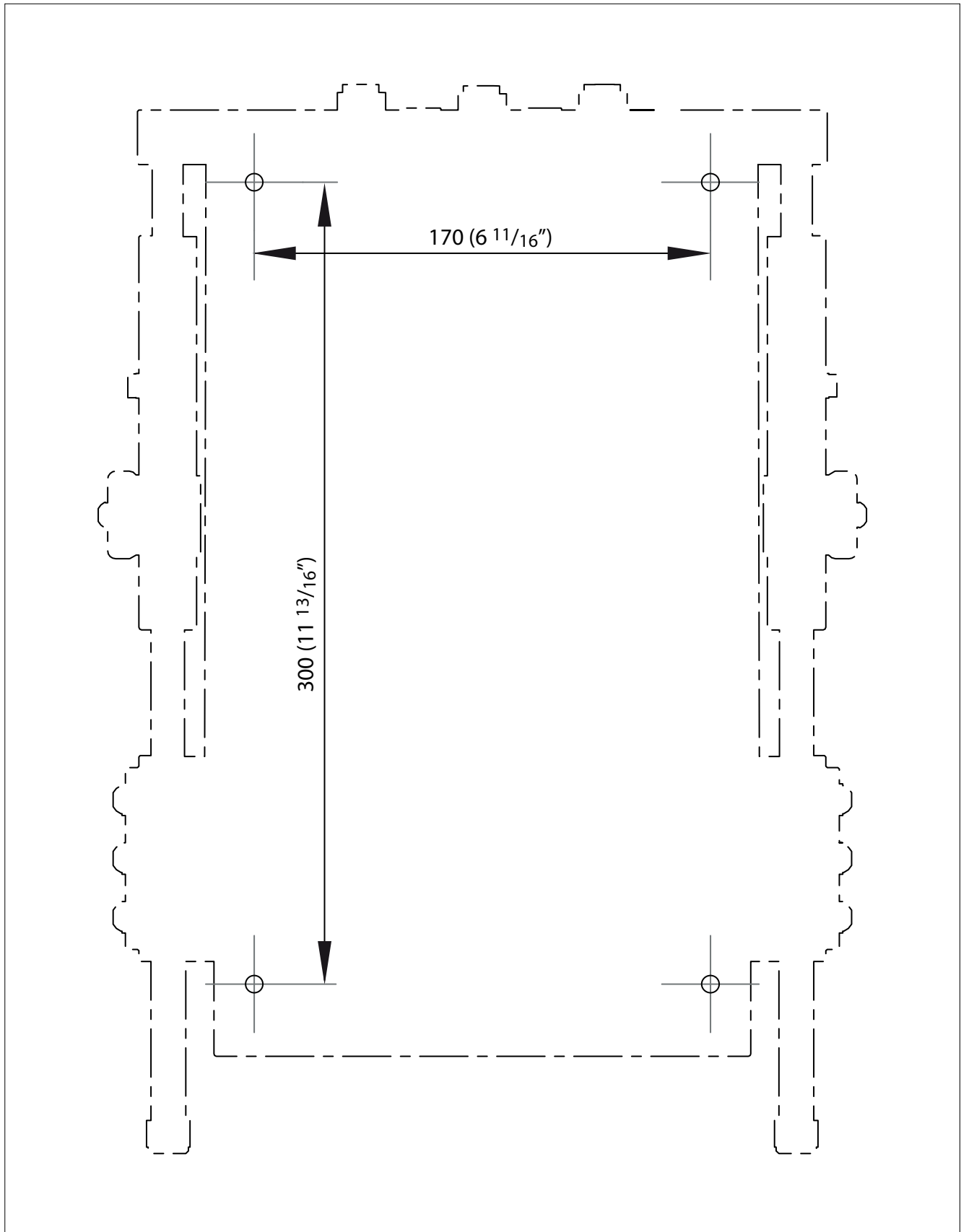

**Attention:** drawings here depicted are not corresponding to the object's real physical size





Points de collecte sur [www.quefairedemesdechets.fr](http://www.quefairedemesdechets.fr)  
Privilégiez la réparation ou le don de votre appareil !



Tel.: +31 (0)88 4884700 - [sales@vetus.com](mailto:sales@vetus.com) - [www.vetus.com](http://www.vetus.com)